



NEWSOUTH

Funga Obscura

A photo journey among fungi

Alison Pouliot



Classification | Nature |
Photography

Thema | PSQ | AJCD | WNP

March 2025
ISBN 9781761170126
NewSouth 192pp, PB, 213x170mm
RRP AU\$49.99 NZ\$57.99

'I scanned the forest floor around me. I couldn't yet see fungi, but I could smell them. Lowering my nose to the ground, I inhaled a distinctive fungal funk. I rolled over some bark and there they were! Gossamer threads of mycelia wended their way through the layers, weaving them together. Soon these furtive fungi would fashion their mycelia into mushrooms and heave their way through the earth.'

This book is about fungi, and the photography of fungi. The title – *Funga Obscura* – unites the two. Beginning in elemental landscapes of ice and rock, the book traces the evolutionary path of fungi as enablers of life on land, and creators of soils and forests. Crossing continents and ecosystems, we navigate lichen-covered landscapes, crawl in the fungal undergrowth, scale glacial extremes and duck between rainforest shadows.

Alison Pouliot, ecologist and environmental photographer, captures these remarkable lifeforms in this visual love letter to fungi.

Sales Points:

- From the bestselling author of *Wild Mushrooming* (CSIRO, 2021) and *Underground Lovers* (NewSouth, 2023) comes a stunning collection of fungi photography from across Australia and the globe
- An ideal entry point into the world of fungi, as well as a visual feast for the fungi expert, the book brings together 125 stunning photographs of both well-known and hard to spot mushrooms, lichen and other fungal species
- All photographs are taken by the author and are accompanied by her tales of adventure and exploration on the road in search of fungi

About the Author:

Alison Pouliot is an ecologist and environmental photographer with a focus on fungi. Her journeys in search of fungi span northern and southern hemispheres, ensuring two autumns and a double dose of fungi each year. Alison is the author of *Underground Lovers* (NewSouth, 2023, published as *Meetings with Remarkable Mushrooms* by Chicago University Press, 2023), *The Allure of Fungi* and co-author of *Wild Mushrooming*.

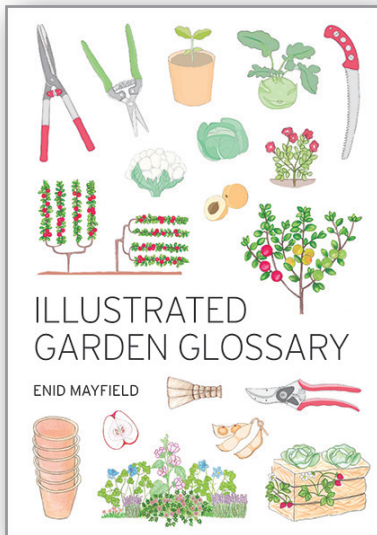

Illustrated Garden Glossary

Enid Mayfield

ISBN	9781486317349
RRP	AU \$64.99
PUBLICATION DATE	03 March 2025
FORMAT	Paperback
EXTENT	160pp
DIMENSIONS	297mm x 210mm x 10.5mm
APPROX. WEIGHT	690 grams
ILLUSTRATIONS	colour illustrations throughout
KEYWORDS	plant classification, garden history, propagation
THEMA CODES	WM, AGNB, 1A

The *Illustrated Garden Glossary* is a comprehensive glossary of over 1000 terms related to gardening and horticulture, each supported by superb colour illustrations to aid understanding.

The topics covered include plant classification, morphology and growth; plants from seeds; propagation; soil; compost; planting systems; pruning; pests and diseases; water and more. It also explores terms relating to the history of gardens, from ancient Greece and Egypt, to gardens across Asia and the Middle East, and through to our modern-day urban farms.

The *Illustrated Garden Glossary* is a must-have reference for gardeners, plant scientists, horticulturalists, students, libraries, ecologists and urban farmers.

KEY INFO

- Covers more than 1000 terms related to gardening and horticulture.
- Includes clearly labelled, colour illustrations of garden terms with key features highlighted.
- Explores the history of gardens across the world.
- Discusses approaches to sustainable gardening.
- Exceptionally thorough and useful for anyone who is passionate about gardening, or who works in or studies horticulture and plant sciences, farming or garden design.
- From the author and illustrator of the *Illustrated Plant Glossary* (CSIRO Publishing, 2021)

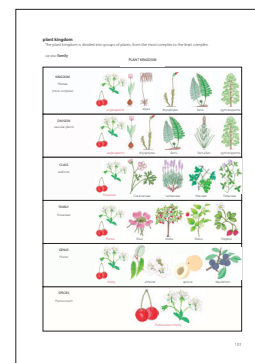
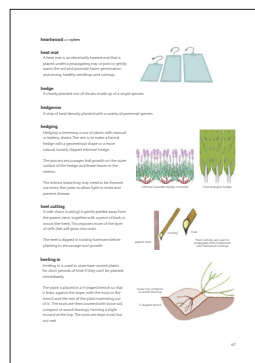
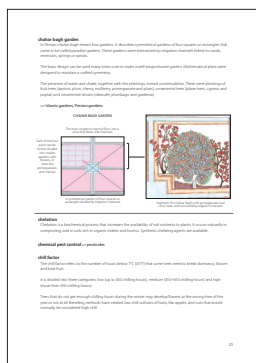

ABOUT THE AUTHOR

Enid Mayfield is a scientific illustrator with experience on a wide variety of publications. Her own titles include the *Illustrated Plant Glossary* (CSIRO Publishing, 2021) and the two-volume *Flora of the Otway Plain and Ranges* (CSIRO Publishing). Enid has been an Honorary Associate of the Royal Botanic Gardens, Melbourne, contributing to the illustration of the 'Flora of Victoria' project, and has maintained an office and studio, and worked closely with the horticultural staff, at the Geelong Botanic Gardens for over 20 years.

This title is co-published by **CSIRO Publishing (ANZ Region)** and **CABI (ROW)**



CONTACT US

Website: www.publish.csiro.au
Local: +(61 3) 9545 8400 or 1300 788 000
Email: publishing.sales@csiro.au

ABN: 41 687 119 230



Jane Austen in 41 Objects

Kathryn Sutherland

13 March 2025

A fascinating insight into the life of one of our best-loved authors through the biographies of objects that crossed her path in life and afterward.

More than 200 years after Jane Austen's death at the age of just forty-one, we are still looking for clues about this extraordinary writer's life. What might we learn if we take a glimpse inside the biographies of objects that crossed her path in life and afterwards – things that she cherished or cast aside, or that furnished the world in which she moved, or that have themselves been inspired by her legacy?

Among objects described in this book are a teenage notebook, a muslin shawl, a wallpaper fragment, a tea caddy, the theatrical poster for a play she attended and the dining-room grate at Chawton Cottage where she lived. Poignantly, the last manuscript page of her unfinished novel and a lock of hair kept by her devoted sister, Cassandra, are also featured. Objects contributing to Jane Austen's rich cultural legacy include a dinner plate decorated by Bloomsbury artists Vanessa Bell and Duncan Grant, Grayson Perry's commemorative pot from 2009 and Mr Darcy's wet shirt, worn by Colin Firth in the 1995 BBC adaptation.

This is a different kind of biography, in which objects with their own histories offer shifting entry points into Jane Austen's life. Each object – illustrated in colour – invites us to meet Jane Austen at a particular moment when her life intersects with theirs, speaking eloquently of past lives and shedding new light on one of our best-loved authors.

Kathryn Sutherland is Senior Research Fellow, St Anne's College, Oxford.

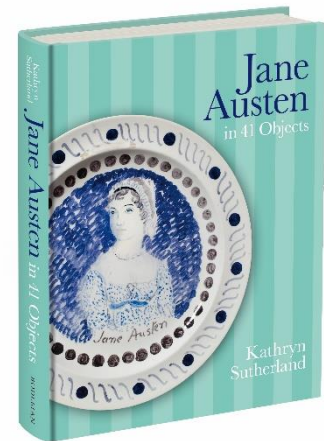

Hardback, £25.00
ISBN: 9781851246267
Extent: 224 pages
Size: 210 x 161 mm
Images: c.70 colour illus

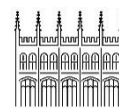

Bodleian Library
UNIVERSITY OF OXFORD

Bodleian Library Publishing
Broad Street
Oxford
OX1 3BG
Tel +44 (0) 1865 283850
publishing@bodleian.ox.ac.uk
Twitter @BodPublishing
Instagram @BodleianLibraryPublishing



Unbound
 9781800183360
 1800183364
 Pub Date: 11/5/2024
 On Sale Date: 11/5/2024
 \$25.00/\$32.99 Can./£17.99
 UK/€21.99 EU
 Discount Code: HC
 Hardcover with dust jacket

352 Pages
 Illustrated throughout
 Carton Qty: 16
 History / LGBTQ+
 HIS066000
 9.4 in H | 6.3 in W
 Status: **ACTIVE**

Related Products
Ebooks
 9781800183377

Queer as Folklore

The Hidden Queer History of Myths and Monsters

Sacha Coward, Joanne Harris

Key Selling Points

- Foreword by author of *Chocolat* (1999), Joanne Harris, which was made into an Oscar-nominated film.
- Images of artefacts and other visual references accompany Sacha's thorough research, as well as five beautiful illustrations by artist Beto Val.
- Sacha has hosted the sold-out event "Dragged Through History" featuring drag queens from RuPaul's Drag Race UK such as Sum Ting Wong, Tia Kofi and Divina De Campo.
- Widely published author who has written articles for a huge number of publications including *Metro*, *Gay Star News*, *National Theatre*, *Art UK*, *Queer Bible*, *Royal Museums Greenwich*, and *Dig It Scotland*, with a focus on LGBTQ+ history and underrepresented audiences in mythology and folklore.
- For fans of Huw Lemmey's *Bad Gays*, *300,000 Kisses* by Luke Edward Hall and Seán Hewitt and *Queer City* by Peter Ackroyd; and for anyone who attends The Mermaid Parade in Coney Island!

Summary

THE SUNDAY TIMES BESTSELLER

***Queer as Folklore* takes readers across centuries and continents to reveal the unsung heroes and villains of storytelling, magic and fantasy. Featuring images from archives, galleries and museums around the world, each chapter investigates the queer history of different mythic and folkloric characters, both old and new.**

Leaving no headstone unturned, Sacha Coward will take you on a wild ride through the night from ancient Greece to the main stage of RuPaul's Drag Race, visiting cross-dressing pirates, radical fairies and the graves of the 'queerly departed' along the way. Queer communities have often sought refuge in the shadows, found kinship in the in-between and created safe spaces in underworlds; but these forgotten narratives tell stories of remarkable resilience that deserve to be heard.

Join any Pride march and you are likely to see a glorious display of papier-mâché unicorn heads trailing sequins, drag queens wearing mermaid tails and more fairy wings than you can shake a trident at. But these are not just accessories: they are queer symbols with historic roots.

To truly understand who queer people are today, we must confront the twisted tales of the past and *Queer as Folklore* is a celebration of queer history like you've never seen it before.

"One delight after another. Told with an open heart, a questing curiosity, and a healthy sense of mischief, *Queer as Folklore* is essential for every seeker of hidden histories."
 — **PATRICK NESS, author of the 'Chaos Walking' series**

Contributor Bio

Sacha Coward is a researcher, historian and public speaker. He has worked in museums and heritage for fifteen years running tours focused on LGBTQ+ history for museums, cemeteries, archives and cities all around the world. Sacha has featured on a variety of television, radio and podcast shows and written articles on topics as varied as Turing's Law, the rainbow flag, Caravaggio's paintings and Viking burials. *Queer as Folklore* is Sacha's first book. He lives in Stroud.

Joanne Harris is an English-French author, best known for her 1999 novel *Chocolat* which was adapted into a film of the same name.

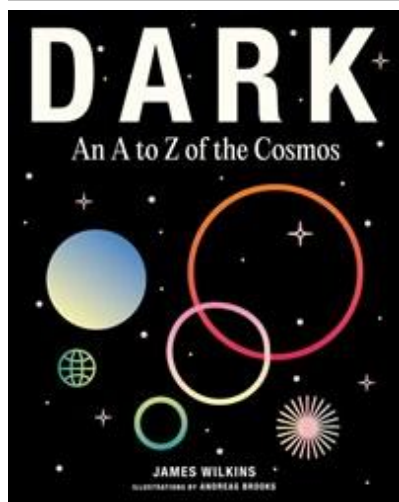

DARK

An A to Z of the Cosmos

James Wilkins, Andreas Brooks

Key Selling Points

- A well-researched, approachable, easy-to-understand beginner's guide to some of the key concepts in astronomy: B for Black Holes, D for Dark Matter, F for the Fermi Paradox, L for the Large Hadron Collider, and so on.
- The book is stylishly designed by Andreas Brooks, and features twenty-six original colour illustrations as well as a bespoke A to Z chapter-heading typeface.

Summary

The beginner's guide to the Universe— in a cosmic, coffee-table book package, perfect for anyone who wants to brush up on their astronomical ABCs.

Ever wanted to cry out, "What on Earth is a black hole?" but been afraid you'd be shouting into the abyss? Ever wanted to find out how gravity works but never found the book to pull you in?

DARK is an easily digestible beginner's guide to the Universe in a handy A to Z format, with entries on everything from Dark Matter and Quantum Physics to NASA and the Zoo Hypothesis.

Includes a number of stunning design elements throughout, including original artworks and bespoke lettering to accompany each of the twenty-six chapters, as well as enlightening and amusing quotes about space rendered in exquisite typography.

Contributor Bio

Hailing from Essex but now living in North London with his wife and two daughters, James spends his days as Creative Director at JOE.co.uk and his nights trying to read 'A Brief History Of Time' to his 3-year-old. Despite not pursuing physics beyond GCSE, his love for all things space and graphic design has led to him spending too many evenings trying to comprehend time-dilation.

Andreas Brooks is a graphic designer living in London. He is currently working on album artwork for Ed O'Brien from Radiohead and a series of book covers for Penguin, as well as being the co-founder of design studio Wide-Eyed. Along with being James' brother-in-law, he also loved space and is responsible for the illustrations and design of the book.

Marketing Plans

- Galleys and e-galleys (Edelweiss, NetGalley) widely available.
- Promotion at ALA.
- Promotion and reviews via social media influencers.
- Young-Adult cross-over, IB programs course adoption promotion.

Table Of Contents

Introduction - 6

A is for Astronomy - 10

B is for Black Holes - 16

C is for Copernican Revolution - 22

D is for Dark Matter - 28

Unbound
9781800182295
1800182295
Pub Date: 10/1/2024
On Sale Date: 10/1/2024
\$29.95/\$38.99 Can./£21.99
UK/€26.99 EU
Discount Code: HC
Hardcover Paper over boards

160 Pages
Illustrated throughout
Carton Qty: 18
Science / Earth Sciences
SCI019000

10 in H | 8.3 in W
Status: **ACTIVE**

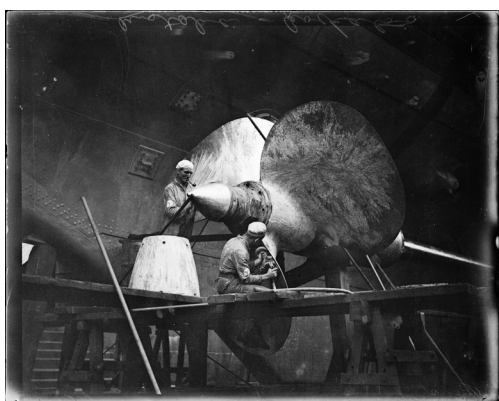

Release Date: 1 MARCH 2025

ISBN: 9781922507907

Format: 230 x 230 mm, paperback

Extent: 96pp

RRP: AU\$19.99

FIT TO PRINT

DEFINING MOMENTS FROM THE FAIRFAX PHOTO ARCHIVE

- Accompanies a major exhibition of the same name at the National Library of Australia in February 2025
- Features a wide variety of photojournalism photography that covers a wide array of styles and subjects and gives a fascinating insight into Australian life
- Showcases iconic images that have appeared in publications such as *The Sydney Morning Herald*, *The Sun* and *Sydney Mail*
- Exhibition will be supported by a full media campaign, including print, radio, digital/social, in Library promotion, large-scale advertising and events

Description

At its very best, photojournalism can define a moment, a movement, an era or a whole generation. It can bring down a careless politician or elevate them to a winning status, it can lift a weary spirit and sometimes it can move opinions and the way we view the world.

Photographer and media commentator Mike Bowers explores the Fairfax Photographic Archive held by the National Library of Australia. This collection comprises over 18,000 glass-plate negatives. Most of the images were captured in New South Wales, while other parts of Australia make up a smaller portion of the collection. Photographs from these negatives appeared in Fairfax publications such as *The Sydney Morning Herald*, *The Sun* and *Sydney Mail*.

Covering the period 1890-1948, the collection covers a range of themes, including: sporting and social events, the opening of the Sydney Harbour Bridge, aviation, rural scenes, industry, politicians, celebrities, and photographs of daily life. In creating photographs for mainstream publications, the early photojournalists familiarised Australians with a new visual language of the news.





On 8 Oct 2024, at 11:38 am, Kelly Ung <kelly.ung@newsouthbooks.com.au> wrote:

Hi everyone,

This is a reminder that submissions for our **MARCH 2025** sales sheets are due. For anyone who hasn't submitted already please send on your sales material for February titles by close of business **TUESDAY OCTOBER 15TH 2024**. Please include new title information (AIs) and high-resolution cover images (300dpi jpg).

It is now a legal requirement that we indicate if any product includes a battery. **Please let us know if any of your titles includes a battery so that we can comply with these new laws.** If you know of any **active backlist titles that include batteries**, please let us know so that we can update our feeds to comply with this change. More information about this can be found here: <https://www.acc.gov.au/media-release/three->

[months-to-go-for-button-battery-safety-standards \[accc.gov.au\]](#)

I would also like to stress the importance of providing **full pdf internals** of your titles along with the cover and AI. **If you would like internals uploaded to Amazon and Booktopia, please also provide four internal images in jpeg format.** Internals do not need to be final and un-proofed manuscripts are more than welcome. We would like to give our sales reps the best opportunity to sell your titles, so we appreciate your help in gathering and sending on internals as soon as they are ready.

Where possible, could you please also include **volumetric data** (depth dimensions in either inches or mm), **unit weight**, and **carton quantity** for all titles being submitted.

Please note the attached spreadsheet is for ebook submissions for the Australian publishers we convert ebooks for only. If you are planning on creating a digital product for your book, please send back along with your AI submission.

Many thanks,
Kelly

Kelly Ung (she/her) | Sales & Marketing Coordinator
NewSouth Books | UNSW | Sydney | NSW 2052
Email: kelly.ung@newsouthbooks.com.au
www.newsouthbooks.com.au

Follow NewSouth Publishing on [Facebook](#), [Instagram](#) and [Twitter](#)
Follow NewSouth Books on [Instagram](#) and [Twitter](#)

Confidential communication – This email and any files transmitted with it are confidential and are intended solely for the addressee. If you are not the intended recipient be advised that you have received this email in error and that any use, dissemination, forwarding, printing or copying of this email and any file attachments is strictly prohibited. If you have received this email in error, please notify me immediately by return email and destroy this email.



NEW BOOK INFORMATION

Title	Age of Doubt	
Subtitle		
Author	Edited by Tracey Kirkman and Gavin Fang	
Blurb	<p>Today, trust seems harder to find than ever before. It's hardly surprising we feel that way. Our politics is polarised, our online world is awash with misinformation, and we've lost faith in our bedrock institutions. Yet, without trust, we cannot work together to solve the big problems we face.</p> <p>But there is a way back. A way to rediscover trust in our leaders and institutions. A way to tackle the doubt.</p> <p>This insightful collection of essays brings together top thinkers from across the globe in media, science, government, academia and business to examine how and why trust is disappearing, and how we might navigate these confusing times.</p> <p>It explores the origins of our misinformation culture and its impact on democracy. It looks at the moral and ethical foundations our institutions are built on, and shines a light on the media and its role in sorting fact from fiction. Expert minds in business, science and law enforcement explain how to maintain trust and how easily it can be broken, and leaders on the front line of technological development describe the influence of bots, conspiracy theories and generative AI.</p> <p>If we are to address the big issues facing our world, then we must have trust, because without it we have no sense of shared reality. Alone, we can't do it. Together, we might.</p>	

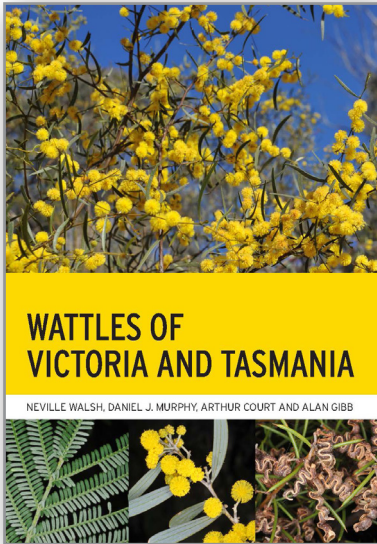

Wattles of Victoria and Tasmania

Neville Walsh, Daniel J. Murphy, Arthur Court, Alan Gibb

ISBN	9781486317967
RRP	AU \$59.99 US \$42.99
PUBLICATION DATE	03 March 2025
FORMAT	Paperback
EXTENT	292pp
DIMENSIONS	245mm x 170mm x 17.5mm
APPROX. WEIGHT	730 grams
ILLUSTRATIONS	115 maps, 436 colour photographs
KEYWORDS	Acacia, illustrated guide, photography, Australia
THEMA CODES	PSTH, 1MBF

Wattles (*Acacia*) are among the most vibrant plants in the southern Australian bush, with their iconic yellow blooms particularly visible in late winter and spring. As the largest genus of flowering plant in Australia, they are one of the most resilient, recognisable and culturally significant native plants. However, they can be difficult to identify at a species level.

This comprehensive guide to all 121 species and subspecies of wattles found in Victoria and Tasmania includes notes on the habitat, distribution and special properties of each species. Identification keys, high-quality field photos and distribution maps enable easy identification, and fascinating detail on the etymology of species names, their use as food and the taxonomic history of the group is also included. This guide will inform and inspire botanists, conservationists and wattle enthusiasts.

KEY INFO

- Provides comprehensive coverage of all species of *Acacia* known to be growing wild in Victoria and Tasmania.
- Includes keys to all species.
- Features photographs (habit, flowers, fruits, seeds) and maps for all species.

ABOUT THE AUTHORS

Neville Walsh worked as a botanist at the National Herbarium of Victoria, initially as a survey botanist and later concentrating on plant taxonomy and conservation. He has named over 130 plant species in a range of families and co-edited the four-volume *Flora of Victoria*. He retired in 2022.

Daniel Murphy is a systematic botanist at the Royal Botanic Gardens Victoria. He has a particular interest in the evolutionary history of Australia's flora and the historical connections of this flora to other parts of the world, and has focused much of his research on *Acacia* and related legumes.

Arthur Bertram Court (1927–2012) was a dedicated botanist known for his expertise and passion for the *Acacia* genus. He served as the Australian Botanical Liaison Officer (ABLO) at the Kew Gardens in London from 1966 to 1967, took on the role of Curator of the Herbarium at the Canberra Botanic Gardens (later the Australian National Botanic Gardens) in 1974 and became the Assistant Director of National Collections in 1983. The plant *Acacia courtii* – commonly known as the North Brother Wattle – was named in his honour.

Alan Gibb (1943–2022) was a farmer, bushman and self-taught photographer. Known for his deep knowledge of flora and fauna, his wildlife photography has been exhibited and used for various publications. He led nature tours through outback Australia for many years where his particular love of Australian wattles was nurtured. The Mt Typo Wattle (*Acacia boormanii* subsp. *gibba*) was named in his honour.



CONTACT US >

Website: www.publish.csiro.au
Local: +(61 3) 9545 8400 or 1300 788 000
Email: publishing.sales@csiro.au

PUBLISHING

ABN: 41 687 119 230



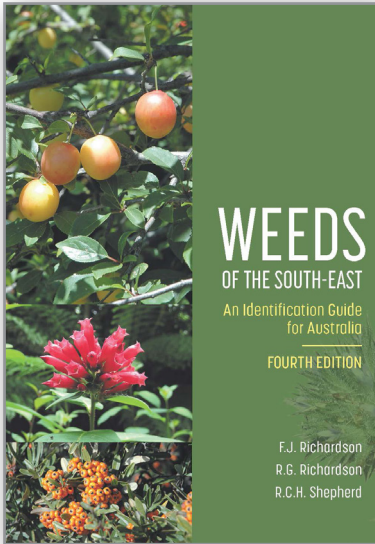

Weeds of the South-East

An Identification Guide for Australia

FOURTH EDITION

F. J. Richardson, R. G. Richardson, R. C. H. Shepherd

ISBN 9781486317042
RRP AU \$99.99 | US \$69.99
PUBLICATION DATE 03 March 2025
FORMAT Paperback
EXTENT 576pp
DIMENSIONS 245mm x 170mm x 28mm
APPROX. WEIGHT 1400 grams
ILLUSTRATIONS 3000 colour photos
KEYWORDS weed identification, south-east Australia, bushland, waterways, agriculture
THEMA CODES PST, 1MBF

Weeds of the South-East is a comprehensive identification guide to weeds found in the South-East region of Australia, covering the whole of Victoria, Tasmania and the Australian Capital Territory, the southern half of New South Wales and the south-eastern section of South Australia. This fourth edition has been thoroughly updated to include recent changes in nomenclature, bringing all species and genus names in line with the current Australian Plant Census.

Beautifully illustrated, this is a detailed guide for anyone interested in the identification of pest plants and the preservation of our native flora. It is an essential tool for community land and bushcare organisations, local and state government weed officers and advisers, rangers, agronomists, agriculturists, survey and identification botanists, horticulturists, landscapers and gardeners.

KEY INFO

- Species include weeds of agriculture, bushland, waterways, gardens, roadsides, wasteland and amenity areas, as well as new and emerging problem species.
- Illustrated with more than 3,000 photographs, including spectacular close-up shots.
- Key features are described with relevant measurements for easier identification.
- Comparisons are made to similar species and easily confused natives.

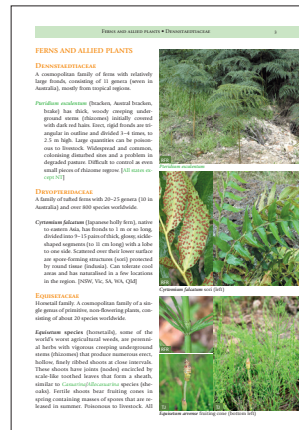

ABOUT THE AUTHORS

Fiona J. Richardson gained her Honours degree in Art and Sociology from the University of London in 1978. She worked as a market and business research consultant in Europe before emigrating to Australia in 1994. She now specialises in book design and typesetting, as well as continuing her interest in plant identification and photography.

Rob G. Richardson gained his Master of Agricultural Science from the University of Melbourne in 1976. He spent the first half of his career as a research scientist at the Keith Turnbull Research Institute in Frankston, Victoria, working on the physiology and ecology of weeds, and the application and formulation of herbicides. Rob is now retired, and a keen sailor and plant photographer.

Ros C. H. Shepherd gained her Master of Science from the University of Queensland in 1966 and Master of Agricultural Science from the University of Melbourne in 1984. She spent many years as an entomologist at the Keith Turnbull Research Institute in Frankston, Victoria, working on the biological control of pest plants and animals, which included research in South Africa. Ros has travelled around Australia and the world photographing and documenting plants, and is now retired.



CONTACT US

Website: www.publish.csiro.au
Local: +(61 3) 9545 8400 or 1300 788 000
Email: publishing.sales@csiro.au

ABN: 41 687 119 230



Saving Heritage Breeds *A Love Story*

Catie Gressier

Driving through the countryside, you may have noticed that nowadays it's paddock after paddock of merino sheep, while virtually every cow lining up for milking is black and white. Your neighbours' backyard chooks are likely to be Isa Browns. You probably can't even remember the last time you saw a pig, because they're all hidden away in sheds.

An extinction crisis is quietly unfolding on our farms. Since mid-last century, advancements in animal husbandry have resulted in the global adoption of a small number of fast-growing, high-yielding livestock types. While performance and profitability gains have been extraordinary, they have led to the extinction of a unique livestock breed globally each month for over three decades. This book tells the story of the Australian farmers working hard to save the remaining heritage breeds of cattle, sheep, pigs and poultry. Gressier argues that heritage breed farmers are motivated by one of the most powerful conservation tools we have: love.

Catie Gressier is an Adjunct Research Fellow in the School of Agriculture and Environment at the University of Western Australia, and a PhD candidate in Creative Writing at Curtin University.

SALES POINTS

- o *Saving Heritage Breeds* is the third book in the new non-fiction series, *Vignettes*, from UWA Publishing.

ABOUT VIGNETTES

Series Editors: Sarah Collins and Tony Hughes-d'Aeth

The *Vignettes* series from UWAP is aimed at sharing the knowledges that are emerging in the contemporary university space and consider the complexities of modern life. Each book provides an image, or a vignette, of a particular phenomenon and how this is being thought through by intellectual practitioners in today's academy.

ABOUT THE AUTHOR

Catie Gressier is a cultural anthropologist whose research explores foodways, tourism, and health and illness. She is the author of *At Home in the Okavango: White Batswana Narratives of Emplacement and Belonging* (Berghahn), and *Illness, Identity and Taboo among Australian Paleo Dieters* (Palgrave). Catie is an Adjunct Research Fellow in the School of Agriculture and Environment at UWA, and a PhD candidate at Curtin University. She is a Director of the Board of the Rare Breeds Trust of Australia, an Editorial Board member of *Anthropological Forum*, and the Coordinator of the Ecology, People, Place (EcoPeoPle) research network.

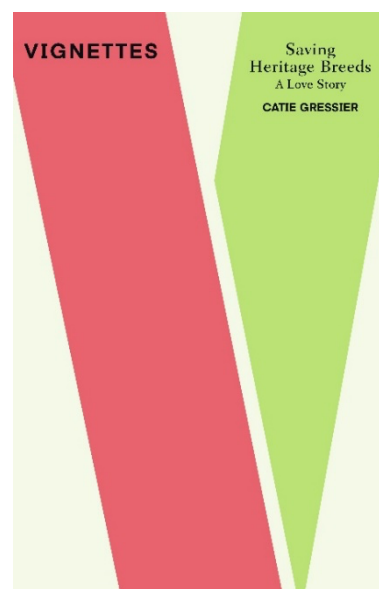

PUB DATE

17 March 2025

ON SALE

17 March 2025

ISBN

9781760803025

PRICE

\$22.99 AUD incl GST

RIGHTS

World

FORMAT

B+ paperback
165(H)x120(W)mm
120 pages approx
0.3kg

THEMA CATEGORIES

TVH; 1MBF

KEYWORDS

Non-fiction; Animal Husbandry; Heritage Breeds; farming

RELATED PRODUCTS

Nefflicks
978-1-76080-272-1

The Moment of the Essay
978-1-76080-274-5



For all enquiries please contact UWA Publishing
marketing-uwap@uwa.edu.au
+61 8 6488 3670
www.uwap.com.au
M419, 35 Stirling Hwy, Crawley, WA 6009, Australia





Cornerstones of Impact Management

How to Plan, Implement, Assess and Understand Factors for Success

Edited by Anne-Maree Dowd, Thomas Keenan, Kathryn Graham

ISBN	9781486317455
RRP	AU \$99.99
PUBLICATION DATE	03 March 2025
FORMAT	Paperback
EXTENT	340 pp
DIMENSIONS	245mm x 170mm x 19mm
APPROX. WEIGHT	825 grams
ILLUSTRATIONS	54 b&w illustrations
KEYWORDS	impact management, research impact, impact evaluation, organisational management
THEMA CODES	KJU

Cornerstones of Impact Management is a comprehensive and practical guide to the key foundations of impact. It provides insights and expertise from leading practitioners from around the world, who have decades of experience in starting impact management processes from scratch, shifting cultures, developing systems and processes, and establishing leading-edge practices. It explores planning, implementing, scaling and assessing impact interventions, particularly within research and innovation, and policy, contexts.

Whether you're a seasoned impact practitioner or just starting your journey, *Cornerstones of Impact Management* is the definitive resource for understanding and enhancing the impact contribution of your project, team, organisation or broader system of operation. It provides invaluable insights for researchers and research managers, policy makers, evaluators, knowledge mobilisers, and quality improvement practitioners.

KEY INFO

- Covers the four critical areas, or 'cornerstones', of impact management: setting the context for impact; impact planning; implementing, scaling and assessing, including how to embed an impact culture in an organisation; and reflections on future directions in the field.
- Provides useful tips, examples and additional resources drawn from the contributors' lived experience as impact professionals.
- Accessible for beginners in the field while still providing useful insights for more experienced professionals.
- Includes a Foreword by Jonathan Grant, co-founder of the International School of Research Impact Assessment.
- Includes contributions from Paula Adam, Gert Bailling, Jasper Buys, Karen Cosgrove, Anne-Maree Dowd, Peter Duffy, Kathryn Graham, Reesa John, Adam Kamenetzky, Thomas Keenan, Alan O'Connor, Pavel Ovseiko, Alex Pollitt, Mark Taylor, and Amanda Walsh.

ABOUT THE EDITORS

Anne-Maree Dowd PhD is the Executive Manager of Performance and Evaluation at Australia's national science agency, CSIRO. She has led the impact agenda within CSIRO since 2014 and has been involved at the international level on research impact.

Thomas Keenan PhD is the Director of Tractuum, an impact management consultancy based in Queensland, Australia. He led the planning and evaluation activities of the CSIRO Impact Team from 2016 to 2019, and continues to support the advancement of the CSIRO approach to impact management as a consultant.

Kathryn Graham PhD, FCAHS is the Executive Director of the Impact Action Lab at Alberta Innovates, a Canadian research and innovation agency. She has over 25 years of experience in implementing strategic performance management and continuous quality improvement systems across multiple organisations and sectors.

CSIRO Publishing holds rights in the ANZ Region only (ROW to be confirmed)



PUBLISHING

CONTACT US >

Website: www.publish.csiro.au
Local: +(61 3) 9545 8400 or 1300 788 000
Email: publishing.sales@csiro.au

ABN: 41 687 119 230



NEW BOOK INFORMATION

Title	Connected Care
Subtitle	Digital Health in Australia
Author	Richard Royle and David Hansen
Blurb	<p>Imagine a time when any patient, no matter who they are or where they live, can visit their doctor or specialist online and immediately access all the relevant diagnostic information and medical records—a time when a holistic view of a person’s health data and outcomes is literally always at their fingertips. Some of this is a reality now, but the system is clunky, incomplete and inefficient. The fact is that the health sector in Australia, in comparison to industries such as banking and commerce, has been slow to adopt digital methodologies. And even when it has, there has been a frustrating lack of connectivity between e-health technologies, confronting clinicians and consumers alike with information silos.</p> <p>Richard Royle and David Hansen have been closely involved in e-health in Australia for over two decades and are committed to the creation of a digital health system that enables connected care for consumers and health providers across the country. With this goal in mind, in <i>Connected Care: Digital Health in Australia</i> they outline the challenges ahead, and what governments and health providers can do to help build and encourage the uptake of the necessary technology.</p> <p>Australia needs a properly interconnected healthcare system. This will reduce costs and increase efficiencies in what is currently an overstretched sector—and most importantly, it will save lives. A digital health community that reliably provides connected care will deliver greater wellbeing to everyone.</p>
About the authors	<p>Richard Royle Adjunct Professor Richard Royle oversaw a landmark national review in 2013 that led to the establishment of the Australian Digital Health Agency and the My Health Record. He has chaired the CSIRO’s Australian e-Health Research Centre (AEHRC) since 2017 and continues to be closely involved in digital health innovation. He has been the CEO of a number of public and private hospitals over the last forty years, and he spearheaded the development of Australia’s first fully integrated digital hospital in Hervey Bay, Queensland—St Stephens Hospital opened in 2014 and has since won a number of international awards for its comprehensive digital implementation.</p> <p>David Hansen Dr David Hansen is CEO and Research Director of the AEHRC, which has responsibility for CSIRO’s digital health research program. With over 150 scientists and engineers dedicated to all facets of this discipline, from genomics and medical imaging to health data interoperability and virtual care, the AEHRC is Australia’s largest digital health research centre. David has contributed to many other national digital health initiatives and has been a long-term board member of the Australasian Institute for Digital Health. He is passionate about the role of information and communication technologies in health care, and the part digital health professionals can play in developing a safe, high-quality and sustainable healthcare system in Australia.</p>

Cover image

[See attached image](#)

BIBLIOGRAPHIC DETAILS

Publication date	1 March 2025
Stock date	8 February 2025
ISBN (print – PB)	9781922979964
ISBN (ebook – PDF)	9781922979971
ISBN (ebook – EPUB)	9781922979988
URL	TBC
Extent	96 pages
Dimensions	111mm x 175mm (W x H) x 10mm (D)
Weight	0.08kg
Retail price	\$19.95
Series	In the National Interest
Series Description	<p><i>In the National Interest</i> is a series in the Monash University Publishing list that is focused on the challenges Australia confronts. The series informs, influences and inspires public discourse. Showcasing experts both from within Monash and beyond, these short, thought-provoking and accessible books address the major issues of our times, from public policy to governance and government.</p> <p>The series offers eminent researchers, policymakers and political practitioners the opportunity to ‘make the case’. These short books consider a range of issues, including leadership in modern politics, Australia’s role in our region, managing a pandemic, gender affairs, and the role of the public service. The series adds evidence and nuance to debates all too often rendered simplistic.</p> <p><i>In the National Interest</i> offers serious general readers evidence-based arguments that spark informed debate on the issues that matter.</p>
Subject areas	Healthcare, Technology, Digital Health
Thema categories	MBP (Health services and systems) MBPM - (Medical administration and management) MBF - (Medical and health informatics) 1MBF (Australia)
BISAC categories	POL073000 (POLITICAL SCIENCE / Public Policy / Health Care) MED035000 (MEDICAL / Health Care Delivery) MED120000 (MEDICAL / Telemedicine) MED000000 (MEDICAL / General) 6.0.1.0.0.0.0 (Australia)
Keywords	health, healthcare, digital healthcare, e-health, technology, Australia, health sector, healthcare system, medical records, online, Australian government, Australian Digital Health Agency, My Health Record, Australian e-Health Research Centre, AEHRC, digital methodology, care, data



NEW BOOK INFORMATION

Title	Maestro John Monash		
Subtitle	Australia's Greatest Citizen General		
Author	Tim Fischer		
Blurb	<p>Who was the most innovative general of World War One? For Tim Fischer, the answer has to be Australia's 'Maestro' John Monash, a man who, for all the recognition he received in his lifetime and after, has arguably not been given his proper due. Fischer also asks why Monash, Australian Army Corps Commander, was never promoted to Field Marshal, postwar, as international precedent suggested was most appropriate, pointing the finger primarily at the Australian prime minister of the time, Billy Hughes, within a wider context of establishment suspicion towards this son of a German Jewish migrant.</p> <p><i>'A perfected modern battle plan is like nothing so much as a score for an orchestral composition, where the various arms and units are the instruments, and the tasks they perform are their respective musical phrases. Every individual unit must make its entry precisely at the proper moment and play its phrase in the general harmony.'</i></p> <p>– John Monash</p>		
About the author	<p>The Honourable Tim Fischer AC was a former deputy prime minister of Australia and was the Australian ambassador to the Holy See for three years until January 2012. A former Australian Army officer, NSW state parliamentarian, leader of the National Party and minister for trade, Tim Fischer was also a consultant, company director, author, broadcaster, and multiple patron.</p>		



His previous publications include *Seven Days in East Timor: Ballot and Bullets* (2000), *Tim Fischer's Outback Heroes: and Communities that Count* (2002), *Transcontinental Train Odyssey: The Ghan, the Khyber, the Globe* (2004), *Asia & Australia: Tango in Trade, Tourism and Transport* (2005), *Trains Unlimited in the 21st Century* (2011) and *Holy See, Unholy Me! 1000 Days in Rome* (2013).

Cover image

[Attached](#)

BIBLIOGRAPHIC DETAILS

Publication date

1 January 2025 (note same content as Nov 2014 edition)

Stock date

8 December 2024

ISBN (print – PB)

9781922235596

ISBN (ebook – PDF)

n/a

ISBN (ebook – EPUB)

9781922235602

URL

<https://publishing.monash.edu/product/maestro-john-monash/>

Extent

286 pages

Dimensions

153mm x 234mm (W x H) C format

Weight

0.6kg

Retail price

\$32.99

Series

n/a

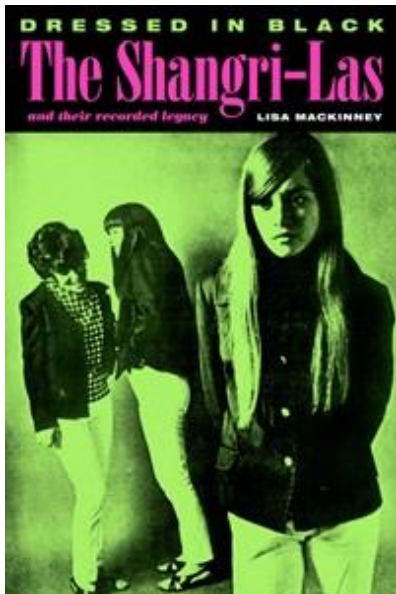

Dressed in Black

The Shangri-Las and Their Recorded Legacy

Lisa MacKinney

Summary

The first full-length history of the Shangri-Las, one of the most significant—and most misunderstood—pop groups of the 1960s.

Sisters Mary and Betty Weiss, together with twins Mary Ann and Marguerite Ganser, were schoolgirls when they formed the Shangri-Las in 1963, and had a meteoric rise to fame with songs like "Leader of the Pack" and "Remember (Walking in the Sand)." Their career was cut short for reasons largely beyond their control, derailed by the machinations of Mafia-linked record executives, and heartbreak and tragedy followed. Historian Lisa MacKinney marshals an impressive array of new evidence to tell the Shangri-Las' story, dispelling many myths and long-standing mysteries along the way.

Equally importantly, *Dressed in Black* radically rewrites the accepted narrative of the Shangri-Las' place in rock history. As young women, they were permitted little agency within a male-dominated industry that viewed teenagers as fodder to be manipulated and exploited by producers, songwriters, and label owners. For decades, this has served as an excuse for critics to deny the musical input of the group members, to trivialize the Shangri-Las as a "girl group," and to assign their work a lesser rank in the canon of "authentic" rock and roll. MacKinney's great achievement here is to foreground the Shangri-Las' considerable abilities and musicality, and establish the centrality of their *performance* of their songs to the group's underappreciated artistic achievement.

This is not to deny the critical role in the group's success of professional songwriters (including Ellie Greenwich and Jeff Barry) and writer/producer George 'Shadow' Morton, a pioneering and eccentric figure whose self-mythologizing has generated a level of obfuscation that rivals that of the Shangri-Las themselves. MacKinney's clear-sighted account reveals Morton in a completely new light—and as part of a complex ecosystem of musical relationships. Morton wrote and produced highly emotional material specifically for the Shangri-Las because he knew they had the skills to make his mini-operas not only believable, but enthralling. The group members, particularly Mary Weiss, channeled personal anguish into their extraordinary performances, which are central to the songs' impact—no less so than for such classic singers as Ella Fitzgerald and Elvis Presley, who also relied on producers and songwriters for their body of work. The Shangri-Las' impassioned delivery elicited a massive response from their audience of fellow teenagers at the time and has continued to connect profoundly with audiences ever since. MacKinney backs up these arguments with in-depth analysis of key Shangri-Las' recordings, and makes a powerful case that their achievements warrant a far more prominent place for the Shangri-Las in the history of popular music.

Contributor Bio

Lisa MacKinney is a historian and musician from Melbourne, Australia. Her book *Dressed in Black: The Shangri-Las and Their Recorded Legacy* is based on her PhD thesis (University of Western Australia), and she has contributed numerous articles to academic journals, books, and music magazines, including *Uncut* and *Limelight*. MacKinney plays guitar and organ, and has performed extensively in Australia and internationally, both solo as Mystic Eyes and with bands, including Super Luminum, Taipan Tiger Girls, and Hospital Pass.

Illustrations



Verse Chorus Press

9781959163077

1959163078

Pub Date: 18/03/2025

On Sale Date: 18/03/2025

Ship Date: 14/02/2025

\$24.95/\$32.99 Can./£23.99

UK/€21.99 EU

Trade Paperback

400 Pages

30 Illustration(s)

Carton Qty: 16

Music / Genres & Styles

MUS035000

22.9 cm H | 15.2 cm W

Status: **FORTHCOMING**

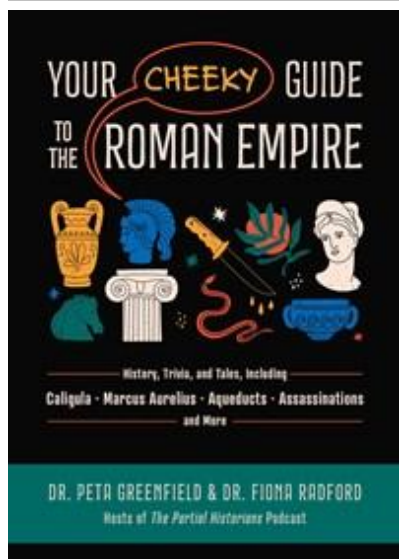

Your Cheeky Guide to the Roman Empire

History, Trivia, and Tales, Including Caligula, Marcus Aurelius, Aqueducts, Assassinations, and More!

Peta Greenfield, Fiona Radford

Summary

Discover the wild and fascinating true stories of the Roman Empire that are rarely taught in history class with this ultimate collection of notorious emperors, scandalous love affairs, rebellion, and more!

Whether you think about the Roman Empire every day or not, the legendary stories and fun facts in this book of ancient Roman history are sure to shock you. Discover the lengths Romans would go to please the gods, the most torrid love affairs, the fun that emperors had to create to keep themselves entertained, and the never-ending scandals that caused serious outrage in ancient Roman society. This collection of trivia and history includes:

- The fall of Crassus, one of the most powerful Romans in his day
- The tale of the goddess Vesta, who saved Tuccia, a priestess wrongly accused of losing her chastity
- The story behind the Romans developing a cult for the goddess Cybele, also known as the "Mother of the Gods"
- And much more!

Whether you're a Roman Empire enthusiast or someone whose knowledge only comes from the movie *Gladiator*, this book has facts and trivia that will be sure to both educate and entertain you!

Contributor Bio

Peta Greenfield (Dr. G) holds a doctor of philosophy in ancient history and classics from the University of Sydney and has taught history and literature for over 15 years. She has bylines in *Ancient World Magazine*, *Bad Ancient*, *Byteside*, *Classicum*, and is the coauthor of *Rex: The Seven Kings of Rome*. Besides being a cohost of the wildly popular podcast *The Partial Historians*, Peta has also reached millions through collaboration with TED-Ed. She loves terrible puns and all cats, and finds the Romans funny despite how serious they are.

Fiona Radford (Dr. Rad) holds a doctor of philosophy in ancient history from Macquarie University. Fiona's bylines appear in *Ancient World Magazine*, *Bad Ancient*, and *Classicum*, and she is the coauthor of *Rex: The Seven Kings of Rome*. For the past decade, Fiona has cohosted the *The Partial Historians* podcast, which has been gradually expanding its influence over all other Roman history podcasts. She laughs way too often and loudly, and usually it is about the Romans. She aspires to be Agrippina the Younger when she grows up.

Illustrations

Ulysses Press
9781646047338
1646047338
Pub Date: 11/5/2024
\$15.95/\$21.95 Can./£15.99 UK
Trade Paperback

312 Pages
Carton Qty: 32
History / Civilization
HIS039000

7 in H | 5 in W | 1 in T | 0.6 lb Wt
Status: **ACTIVE**



NEW BOOK INFORMATION

Title	The History of the Book volume 1
Sub title	From Convict Printers to Book Arcades
Author	Edited by Wallace Kirsop, Elizabeth Webby and Judy Donnelly
Tagline	TBC
Blurb	<p>European printing technology came in the 1790s to a continent where there were – and still are – age-old modes of communication developed by Indigenous Australians. The present volume, while recognising this essential prehistory, is devoted to the print civilisation imported by the newcomers.</p> <p>Throughout the nineteenth century books, magazines and newspapers arrived in great quantities from elsewhere, notably the British Isles. Appropriate means of distribution – bookshops and libraries – were created in the various colonies, but, as the population grew after the gold rushes, local manufacturing became evermore necessary.</p> <p>From the efforts of convict and ex-convict printers before 1820 to the achievements of numerous professionals after 1850, one can follow the expansion of production, dissemination and reading. Alongside the Bush, there were urban centres like Melbourne and Sydney, ranking in size with many major European cities by 1890. Thus, it was possible to find in Victoria's capital what was plausibly claimed to be the biggest bookshop in the world: Cole's Book Arcade.</p>
About the editors	<p>Wallace Kirsop taught French at the University of Sydney and Monash University between 1955 and 1998. From 1968 to 2002 he was editor of the <i>Australian Journal of French Studies</i>. Since the 1960s his research and publications have centred on the book world in <i>ancien régime</i> France and nineteenth-century Australia.</p> <p>Elizabeth Webby (1942–2023) was for many years Professor of Australian Literature at the University of Sydney and editor of <i>Southerly</i>. Her numerous publications concerned, in particular, books and reading in Australia in the first half of the nineteenth century.</p> <p>Judy Donnelly, trained as a librarian at the University of Toronto, was project manager for <i>A History of the Book in Canada/Histoire du livre et de l'imprimé au Canada</i> and director and co-editor of <i>Historical Perspectives on Canadian Publishing</i>. In Melbourne, she worked as an archivist/historian and editor before joining the <i>HOPA</i> team.</p>



Author image	TBC
Cover image	TBC

BIBLIOGRAPHIC DETAILS

Publication date	1 February 2025
Stock date	November 2024
ISBN (print – HC)	9780648738541
ISBN (ebook – PDF)	tbc
ISBN (ebook – EPUB)	9780648738558
URL	TBC
Extent	516pp
Images	35 colour and b&w images throughout
Format	C-format hardcover with jacket
Dimensions	153mm x 234mm (W x H)
Weight	TBC
Retail price	\$50.00
Subject areas	History of Literature, Writing, Printing, Publishing
Thema categories	TBC
BISAC categories	TBC
Keywords	TBC
Sales/Marketing points	<ul style="list-style-type: none">• Please note this is a distribution arrangement only• Jeffreys Booksellers are keen to sell books at launch (tbc)

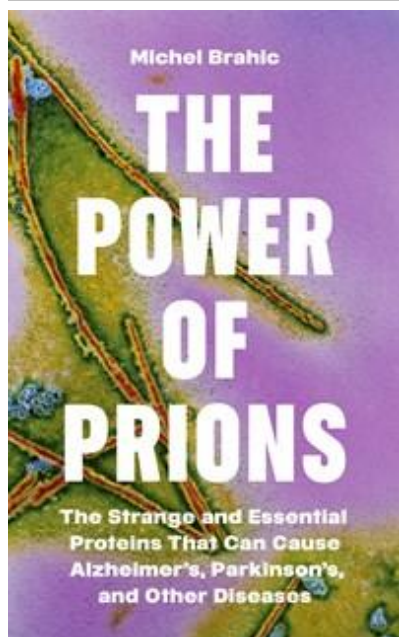

Princeton University Press
9780691252384
0691252386
Pub Date: 10/29/2024
On Sale Date: 10/29/2024
\$24.95/\$32.00 Can./£20.00
UK/€24.99 EU
Discount Code: TC
Hardcover

192 Pages
11 b/w illus.
Science / Life Sciences
SCI089000

8 in H | 5 in W
Status: **ACTIVE**

The Power of Prions

The Strange and Essential Proteins That Can Cause Alzheimer's, Parkinson's, and Other Diseases

Michel Brahic

Summary

The remarkable family of proteins that can make us very ill—but can also be linked to long-term memory, immunity, and the origin of life

Over the last decade, scientists have discovered the importance and widespread presence in the body of a remarkable family of proteins known as prion proteins. Research links various types of prion proteins to neurodegenerative diseases such as Parkinson's and Alzheimer's—and this has fueled the search for new drugs that could halt the progression of these terrible disorders. Other discoveries have revealed the essential roles prion proteins play in memory and immunity, and—in an extraordinary finding—the part they may have played in the beginnings of life on our planet. In this engaging and accessible book, Michel Brahic tells the story of these amazing and versatile proteins.

Brahic, a leading researcher on diseases of the central nervous system, first describes the discovery of prions and their role in infection, beginning with early work on the animal disease scrapie and a mysterious human illness in New Guinea, apparently transmitted by cannibalism. Prions were eventually identified and named by Stanley Prusiner in the 1980s. (Brahic tells us Prusiner's alternate name for prion was "piaf.") Prion proteins were then revealed as the cause of other illnesses, from "mad cow" disease and its human counterpart, Creutzfeldt-Jakob disease, to such noninfectious brain disorders as Parkinson's and Alzheimer's. While the prion proteins responsible for diseases are definitively "bad," Brahic also explains that these abnormal prions are rare exceptions. Most of the time, prion proteins actually serve "good" and vital functions—and they may even have been present at the origin of life itself.

Contributor Bio

Michel Brahic, an expert in viral and prion infections of the brain, is Professeur Honoraire at Institut Pasteur in Paris. He has been Directeur de Recherche at CNRS and Consulting Professor at Stanford University School of Medicine. His work has been published in *Nature*, *Cell*, *New Scientist*, and other journals.

Quotes

"Michel Brahic provides a thorough history of prion proteins that delves beyond their well-documented role in neurodegenerative diseases. A prion researcher himself, Brahic expertly details the origins of his field."---**Francisco J. Rivera-Rosario, *The Transmitter***

"Michel Brahic provides a close-up view of these mysterious proteins. . . . [and] provides a clear, straightforward overview of how the nervous system and proteins function."---**Ed Cara, *Gizmodo***

Unpublished Endorsements

"A fascinating story, showing how the study of a strange sheep disease and a rare neurological human disease led to the revolutionary conclusion that a protein could be infectious – and how this notion shed new light on major neurodegenerative diseases, as well as on several unexplained biological phenomena. Anyone interested in science should read this book." —**Maxime Schwartz, former president of the Institut Pasteur**

"*The Power of Prions* is an amazing read on a truly fascinating topic. From the discovery of prions to the latest and greatest findings, the book provides a uniquely

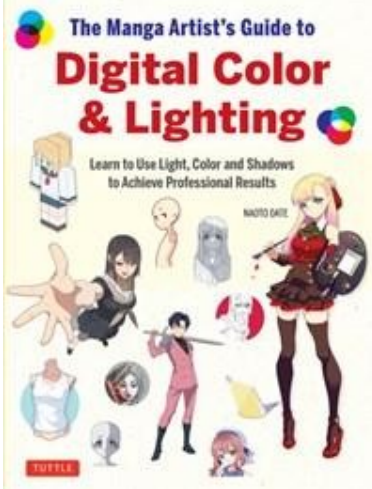

Tuttle Publishing
9784805318881
A\$32.99
Trade Paperback

144 Pages
with 750 illustrations
Carton Qty: 24
Art / Techniques
254mm H | 191mm W
Status: **FORTHCOMING**

The Manga Artist's Guide to Digital Color & Lighting

Learn to Use Light, Color and Shadows to Achieve Professional Results

Naoto Date

Key Selling Points

- A detailed guide for digital manga artists focusing on color, light and shadows —essential topics that all artists need to master to create unified and balanced illustrations
- Offers specific color palettes and combinations with CMYK and RGB percentages throughout
- A "must-have" guide for artists seeking to expand their use of digital shading, coloring effects and the use of light
- An entire chapter is devoted to the common pitfalls and errors artists need to avoid
- Informative "Take a Closer Look" sidebars offer deep dives into specific details like skin shading, color saturation and graphic design principles

Summary

Expand your digital drawing skills with vivid colors and dramatic lighting effects!

Color, lighting and shadows are critical components of effective manga and anime illustrations. This comprehensive guide covers topics every artist needs to know, offering expert guidance you won't get anywhere else.

In this highly detailed book, you'll learn how to:

- Create natural-looking color schemes with the right balance of light and dark areas
- Control the reader's gaze through the use of specific colors and shadow areas
- Create three-dimensional effects using lighting, shadows and color
- Finish your illustrations with color and shading to give them a strong sense of unity
- And much more!

Creative, cohesive color choices. Bold and eye-catching shadows and lighting effects. Raise your manga and anime illustrations to a whole new level by learning these professional-level color and lighting techniques!

Contributor Bio

Naoto Date is the author of two top-selling Tuttle manga and anime guides: *Drawing Manga: Tell Exciting Stories with Amazing Characters and Skillful Compositions* and *The Complete Guide to Drawing Manga & Anime: A Comprehensive 13-Week "Art Course" with 65 Clear and Easy Daily Lessons* (coauthored with Kiyoshi Nitou). A professional illustrator and online drawing instructor, his other publications include *How to Draw Clothing for Manga: Learn to Draw Amazing Outfits and Creative Costumes for Manga and Anime*, *Drawing with Digital Tools* and *How to Draw Wrinkles and Shadows*.

Illustrations



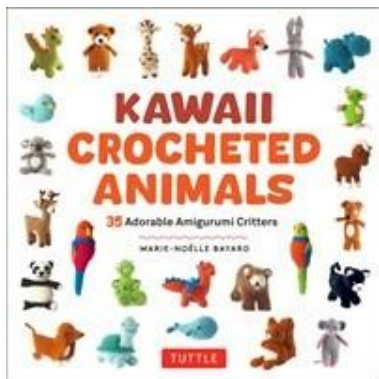

Tuttle Publishing
9780804858021
A\$29.99
Trade Paperback

144 Pages
35 projects; with 75 full-color
photographs and 65 illustrations
Carton Qty: 30
Crafts & Hobbies / Needlework
203mm H | 203mm W
Status: **FORTHCOMING**

Kawaii Crocheted Animals

35 Adorable Amigurumi Critters

Marie-Noelle Bayard

Key Selling Points

- Shows you how to make 35 super-cute crocheted animal figures—from real to mythical
- This book provides all the information that amigurumi enthusiasts need: Essentials Techniques, Supplies & Materials and the Basic Building Blocks to create adorably cute kitties, hedgehogs, dragons and more!
- Easy-to-follow instructions with clear color photographs and illustrations for each project
- Amigurumi crochet is a fast-growing craft category, with top sellers posting sales of over 100K copies

Summary

Create a super-cute collection of amigurumi crocheted animals!

This easy-to-follow guide features simple patterns and instructions showing you how to make 35 different Kawaii-style amigurumi figures! This book provides everything the amigurumi enthusiast needs:

- **Essential Techniques:** A step-by-step rundown of basic crocheting techniques with 65 detailed illustrations
- **Supplies & Materials:** All you need to get started are a standard crochet hook and worsted weight yarn!
- **Basic Building Blocks:** Many of the amigurumi animals featured in the book share the same head and body pattern, so the techniques you learn are carried over from one project to the next!

This ultimate guide shows you how to make 36 different amigurumi animals, including:

- Kawaii kitties and cute canines you'll want to curl up with
- Plush penguins with fun flipper feet
- Adorable hedgehogs with soft, bristly backs
- Darling dragons, fantasy friends and unicorns uniquely your own
- Four fabulous bears: polar, panda, teddy or a brown buddy
- And many more!

Cool and cute kawaii amigurumi animals created with your own hands! Take your crochet hook to the wild side with this fabulous collection.

Contributor Bio

Marie-Noelle Bayard is the author of numerous best-selling fiber-based craft guides in her native France, including *A Macrame Manual*, *The Sashiko Guide*, *The Embroidery Guide* and *My Course in Sergers*.

Illustrations





Tuttle Publishing
9780804857413
A\$42.99
Hardcover Paper over boards

176 Pages
60 recipes; over 100 color photos;
intriguing notes from a local food
expert
Carton Qty: 12
Cooking / Regional & Cultural
241mm H | 203mm W
Status: **FORTHCOMING**

Vietnamese Food and Food Culture

A Life-Changing Journey through the Street Foods, Regional Cooking Styles and Local Ingredients of Vietnam

Paul B. Kennedy

Key Selling Points

- An insider's look at Vietnamese food and cooking through the eyes of a long-time Vietnam resident and food professional
- Author Paul Kennedy is a restaurateur, photographer and world traveler who spent the past 5 years exploring and documenting Vietnamese cuisine
- The 60 recipes, over 100 photos and 24 essays in this book provide a sense of exploration and discovery that will appeal to foodies and professional chefs alike
- Presents many of the classic recipes Vietnam is known for as well as regional and street food delicacies little known outside Vietnam
- Includes dozens of essays covering a range of interesting topics, from unusual foods and unique customs to local etiquette, faith traditions, folklore and distinctive elements of daily life in Vietnam
- Official author website: paulbkennedy.com
- Official author X (Twitter): [@paulinvietnam](https://twitter.com/paulinvietnam)
- Official author Instagram: [@paul_b_kennedy](https://www.instagram.com/paul_b_kennedy)
- Author available for interviews; contact publicity@tuttlepublishing.com

Summary

Experience the vibrant street markets and bustling food stalls of Vietnam first-hand!

In 2018 veteran restaurateur, author, foodie and all-around travel junkie Paul Kennedy embarked on a life-changing journey to Vietnam. His main goal was to explore the nation's rich cuisine and food culture, which had always fascinated him from afar, but which he could never quite understand fully.

This book is the result of five years spent traveling the length and breadth of the country, experiencing Vietnamese food up-close as no other food writer has before.

In 24 essays, 60 recipes and 100 photographs, Kennedy shares his experiences with you through:

- **Engaging stories** about tantalizing local foods and drinks—such as the unparalleled Nam Dinh City Bahn Mi and fresh Bia Hoi beer— and palate-challenging local delicacies—like bitter melon and the foul-smelling durian
- **Intriguing myths, rituals and beliefs**—such as the legendary sword-snatching golden turtle of Hoan Kiem Lake and the outlawed "Coconut Religion"
- **Information on Vietnamese herbs, condiments and ingredients**—from fish sauce to rice paper wrappers to fresh basil, green onions and sawtooth coriander
- **Recipes for classic street food dishes** like Rice Paper Pizza, Banh Mi Sandwiches and Steamed Coconut Rice Cakes with Toasted Shrimp Flakes
- **Iconic restaurant and homestyle dishes** like Spicy Lemongrass Chicken, Crispy Pan-Fried Trout and Baby Basket Clam Rice
- **Unusual drinks and desserts** like Egg Coffee, Mango Margaritas, Coconut Cream Martinis, Tofu Pudding and Vietnamese Layer Cake
- **Plus many other unique flavors, recipes, food discoveries** and dozens of cultural observations from the author while living in Vietnam

Contributor Bio

Paul B. Kennedy has worked in the restaurant industry for 30 years—bringing delicious meals and welcoming environments together to create fond memories. Paul studied hotel management and received a degree in culinary arts from Johnson &

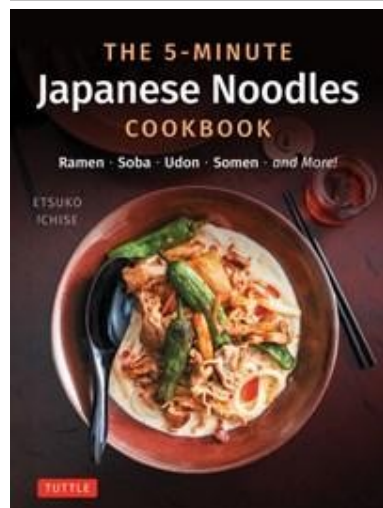

Tuttle Publishing
9784805318843
A\$29.99
Hardcover Paper over boards

96 Pages
67 Recipes plus Variations; 150
color photos
Carton Qty: 20
Cooking / Regional & Cultural
254mm H | 191mm W
Status: **FORTHCOMING**

The 5-Minute Japanese Noodles Cookbook

Ramen, Soba, Udon, Somen and More!

Etsuko Ichise

Key Selling Points

- Experienced cookbook author and TV personality Etsuko Ichise shows you how to make an amazing array of 67 different noodle dishes from scratch in just 5 to 15 minutes!
 - Short ingredient lists and illustrations of all the ingredients needed make these recipes a snap to prepare, even for beginners—with recipes designed to help you avoid food waste!
 - All recipes are for 2 people and use fresh, unprocessed ingredients that are naturally low in calories and sodium—perfect for health-conscious eaters
 - Each recipe is accompanied by a full-color photograph and helpful time-saving tips
 - Endless variations and add-on toppings make these dishes super versatile
-
- Official author website: e-ichise.com
 - Official author Instagram: [@ichise_etsuko](https://www.instagram.com/ichise_etsuko)

Summary

Calling all noodle lovers! Learn to prepare a delicious and satisfying bowl of noodles in less time than it takes to order takeout!

Etsuko Ichise is a woman on a mission—her motto is: "Delicious and easy-to-prepare homestyle cooking!" She shows you how to make simple, homestyle noodles that are incredibly flavorful and healthy yet take only minutes to prepare. Her recipes are light, tasty and healthy thanks to the use of fresh seasonal ingredients purchased at your local supermarket.

And, you will never have to make the same noodles twice! Her mix-and-match ingredients and toppings use chicken, beef, pork, bacon, tofu, eggs and vegetables—whatever you have in the fridge. Each recipe has multiple variations and extra toppings for flavor and complexity—green onions, grated cheese, corn kernels, roasted peanuts, shredded nori, grated ginger, toasted sesame, bean sprouts or chili oil...to name just a few!

Discover an entire universe of noodle flavors:

- **Noodles in a Soy-Based Broth** — Like Hot and Sour Noodle Soup with Pork and Mushrooms or Pork, Kimchi and Soy Milk Udon
- **Noodles with a Dipping Sauce** — Like Ramen with Crab Sticks and Lemon Dipping Sauce or Mixed Soba with Tuna, Wakame and Ginger
- **Noodles in a Miso Flavored Soup** — Like Sesame Miso Somen Champuruu with Spinach or Simmered Miso Udon with Pork Belly and Leek
- **Stir-fried Noodles** — Like Yakisoba Stir-fried with Shirasu, Tomato and Egg or Stir-fried Soba with Sausage and Buttered Corn
- **Cold Noodles & Noodle Salads** — Like Salad-style Hiyashi Chuka with Bacon and Lettuce or Somen with Thinly Sliced Pork, Umeboshi and Cucumber
- **And many more!**

Creamy, slurpy, saucy—as good noodles should be—or dipped into an umami-rich broth. Piping hot, or chilled and finished with delightful fresh toppings. With this much variety, your every noodle craving will be fulfilled!

Contributor Bio

Etsuko Ichise is an expert Japanese chef who has published and contributed to hundreds of cookbooks. She also devotes herself to introducing children to the joys of



Princeton University Press
 9780691215914
 069121591X
 Pub Date: 11/5/2024
 On Sale Date: 11/5/2024
 \$29.95/\$38.00 Can./£25.00
 UK/€29.99 EU
 Discount Code: TC
 Hardcover

248 Pages
 12 color + 70 b/w illus.
 Science / Paleontology
 SCI054000

9.3 in H | 6.1 in W
 Status: **ACTIVE**

Uncovering Dinosaur Behavior

What They Did and How We Know

David Hone

Summary

How scientists are unravelling one of the most tantalizing questions in paleontology

Our understanding of dinosaur behavior has long been hampered by the inevitable lack of evidence from animals that went extinct more than sixty-five million years ago and whose daily behaviors are rarely reflected by the fossil record. Today, with the discovery of new specimens and the development of new and cutting-edge techniques, paleontologists are making major advances in reconstructing how dinosaurs lived and acted. *Uncovering Dinosaur Behavior* provides an unparalleled look at this emerging field of science, presenting the latest findings on dinosaur behavior and explaining how researchers interpret the often minimal and even conflicting information available to them.

David Hone begins by introducing readers to the fundamentals of dinosaur biology, diversity, and evolution, and goes on to describe behaviors across the whole range of species and groups, from feeding and communication to reproduction, sociality, and combat. Speculation about dinosaur behavior goes back to the earliest scientific studies of these “terrible lizards.” Hone traces how pioneering science is opening a window into prehistoric life as never before, and discusses future directions of research in this thrilling and rapidly growing area of paleontology.

Written by one of the world’s leading dinosaur experts and featuring accurate color recreations by paleoartist Gabriel Ugueto along with a wealth of photos and diagrams, *Uncovering Dinosaur Behavior* is a foundational work on the subject and an invaluable reference for anyone interested in these amazing creatures.

Contributor Bio

David Hone is Reader in Zoology at Queen Mary University of London and the author of *How Fast Did T. rex Run? Unsolved Questions from the Frontiers of Dinosaur Science* (Princeton) and *The Tyrannosaurus Chronicles: The Biology of the Tyrant Dinosaurs*. He has written about dinosaurs for leading publications such as *National Geographic*, *The Guardian*, and *HuffPost*. **Gabriel Ugueto** is a leading scientific illustrator and paleoartist whose work has appeared in numerous books, museum exhibits, and documentaries.

Quotes

“This vivid look at the prehistoric past entralls.” -Publishers Weekly

Unpublished Endorsements

“An enthralling read that brings long-dead creatures to life. In this bold, brave, and brilliant book, David Hone provides a fascinating and up-to-date exploration of what we know about how dinosaurs actually behaved.”—**Chris Packham, naturalist and television presenter**

“Fascinating and incisive. This book isn’t just about what we know about dinosaur behavior, but importantly, *how* we know it. In that way, it’s not just a book about dinosaurs or even about animal behavior more broadly, it’s about how science works and how we can hope to answer difficult questions even when the answers seem lost in time.”—**Alice Roberts, author of *Crypt: Life, Death, and Disease in the Middle Ages and Beyond***

“If you want to know what dinosaurs were like as real living, breathing animals, then



Princeton University Press
 9780691264639
 0691264635
 Pub Date: 10/29/2024
 On Sale Date: 10/29/2024
 \$22.95/\$28.99 Can./£18.99
 UK/€22.99 EU
 Discount Code: SP
 Trade Paperback

320 Pages
 115 b/w illus. 4 tables.
 Science / Life Sciences
 SCIO70040

9.3 in H | 6.1 in W
 Status: **ACTIVE**

How Birds Evolve

What Science Reveals about Their Origin, Lives, and Diversity

Douglas J. Futuyma

Summary

A marvelous journey into the world of bird evolution

How Birds Evolve explores how evolution has shaped the distinctive characteristics and behaviors we observe in birds today. Douglas Futuyma describes how evolutionary science illuminates the wonders of birds, ranging over topics such as the meaning and origin of species, the evolutionary history of bird diversity, and the evolution of avian reproductive behaviors, plumage ornaments, and social behaviors.

In this multifaceted book, Futuyma examines how birds evolved from nonavian dinosaurs and reveals what we can learn from the "family tree" of birds. He looks at the ways natural selection enables different forms of the same species to persist, and discusses how adaptation by natural selection accounts for the diverse life histories of birds and the rich variety of avian parenting styles, mating displays, and cooperative behaviors. He explains why some parts of the planet have so many more species than others, and asks what an evolutionary perspective brings to urgent questions about bird extinction and habitat destruction. Along the way, Futuyma provides an insider's perspective on how biologists practice evolutionary science, from studying the fossil record to comparing DNA sequences among and within species.

A must-read for bird enthusiasts and curious naturalists, *How Birds Evolve* shows how evolutionary biology helps us better understand birds and their natural history, and how the study of birds has informed all aspects of evolutionary science since the time of Darwin.

Contributor Bio

Douglas J. Futuyma is Distinguished Professor Emeritus in the Department of Ecology and Evolution at Stony Brook University, State University of New York. His books include *Evolution* and *Science on Trial: The Case for Evolution*. He is a member of the American Academy of Arts and Sciences and the National Academy of Sciences.

Quotes

"A Birdwatcher's Yearbook Best Bird Book of the Year"

"Terrific. . . . Futuyma writes an accessible overview of bird evolution that lay readers, especially birders, will be able to understand." -BirdWatching

"[Futuyma] skillfully weaves together salient themes of evolutionary biology from the living aviary, stressing the important role that birds played in advancing our understanding of evolution."---**Alan Feduccia, *Science***

"This engaging and wide-ranging summary of virtually every aspect of avian evolution synthesizes the earliest insights from Darwin to those of modern phylogenetics, using birds to illustrate each concept. ... [Futuyma] may be the ideal person to explain the marvels of bird evolution."---**Daniel S. Cooper, *The Quarterly Review of Biology***

"How Birds Evolve is accessible, exhilarating science for everyone – amateur birder, professional naturalist or just the average man. It's a great book and one to read over and over and I thoroughly recommend it to all. This is already my Bird Book of 2022 and I can't see it being bettered."---**Phil Slade, *Another Bird Blog***

"*How Birds Evolve* is a book full of accessible and exhilarating science for everyone and not just birders and professional naturalists. It's simply a stunning book and one to read numerous times and an example of the amalgamation of science and nature writing at its finest and I thoroughly recommend it to everyone."---**Roy Stewart,**



Mango
 9781684816446
 1684816440
 Pub Date: 10/29/2024
 On Sale Date: 10/29/2024
 \$39.99/\$54.99 Can./£31.99
 UK/€37.99 EU/\$64.99 AUD
 Discount Code: HC
 Hardcover Paper over boards

256 Pages
 color photographs throughout
 Carton Qty: 18
 Design / Interior Decorating
 DES010000

10 in H | 7 in W | 0.8 in T
 Status: **ACTIVE**

Related Products

Ebooks

9781684816453

Relaxed Maximalism

Curating a Maximalist Home with Soul (Design Styles for your Home, Interior Design Book)

Sarah Laming

Key Selling Points

- There is an exciting new trend in interior design: maximalism. Some call it a rubber band effect to minimalism and perfectionist fatigue. Sarah Laming coins her approach to this trend Relaxed Maximalism.
- One of people’s biggest fears about maximalism is creating a house that is just messy and cluttered, rather than stylishly curated. It does take skill to mix color, pattern, texture, vintage buys, family heirlooms and modern practical pieces in a way that they fit harmoniously together—Sarah Laming shows you how.
- Laming covers everything from planning the basics, to those all-important final flourishes, and explaining all the details in between. She will be illustrating its points with beautiful photographs, sketches, top tips, ideas to steal, and breakdowns of real rooms.
- The book will bridge the gap between people’s desire to bring this kind of design into their homes, and their need to know how to do it.
- Laming’s maximalist approach draws on the very British history of English country house design but with a modern twist.
- Sarah’s philosophy is that you should always create a home that makes you smile, reflects your personality, and your personal history. A home that is curated slowly and layered gradually so that it becomes a reflection of you...a home that is perfectly imperfect!

In *Relaxed Maximalism*, we invite you to break free from the constraints of minimalist design and embrace the joy of a life well-lived through maximalist decor.

Summary

Say Hello to Home Decor Tips Filled with Color, Pattern, and Soul.

In *Relaxed Maximalism*, we invite you to break free from the constraints of minimalist design and embrace the joy of a life well-lived through maximalist decor.

#1 New Release in Architectural Decoration & Ornament and Interior Decoration & Ornament

From minimalist to maximalist home decor. In this comprehensive guide to creating a Relaxed Max home, we address the common concerns of those who want to avoid minimalist austerity without descending into cluttered chaos. How do you infuse your space with personality without sacrificing harmony? How do you mix colors, patterns, textures, and vintage finds to create maximalist décor?

For fans of interior design books. Maximalism, often misunderstood as a style with no rules, is in fact a carefully curated approach that requires knowledge and experience to achieve harmony. Our aim is to entertain, inspire, and enable you on your journey to Relaxed Maximalism. Through beautiful photographs, sketches, top tips, and real room breakdowns, we guide you through every step of the decorating process.

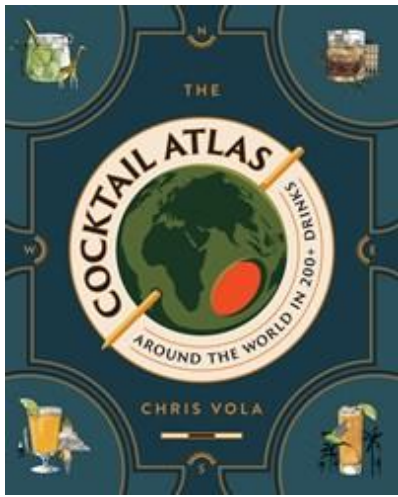

The Cocktail Atlas

Around the World in 200+ Drinks

Chris Vola

Key Selling Points

- **COMPREHENSIVE LOOK AT A POPULAR TOPIC:** Vola's "around the world" approach offers information and recipes that will appeal both to serious mixologists (who are always thirsty to learn about more obscure spirits and drinking traditions) as well as those just starting out. Unlike comparable books on wine and spirits, one does not need to already be an expert to enjoy this book.
- **WELL-POSITIONED AUTHOR:** Chris trained under the late Sasha Petraske, who was credited with bringing high-end cocktails and a speakeasy environment to the cocktail scene of the early 2000s. Chris is also an accomplished writer, holds an MFA from Columbia, and has authored a novel, a short story collection, and two previous books on cocktails.
- **PACKAGE SUMMARY:** The package is a three-piece case with a cloth-like spine and debossed panel, positioning it as an evergreen gift for any occasion, especially for dads and guys who are difficult to shop for.

Summary

***The Cocktail Atlas* takes readers around the world, through the lens of a cocktail glass, exploring the links between people, place, and taste.**

Organized by continent, each country covered has a thorough (and often rollicking) description of its customs, indigenous food and drink, topography, distilling traditions, and cocktail scene. These are followed by at least one cocktail recipe, which is either an iconic beverage of the land or an original interpretation inspired by local ingredients, as well as nuggets and tidbits of knowledge guaranteed to come in handy at the next pub quiz. Visit Lebanon through a Za'atar Paloma; Cyprus via a Cypriot Brandy Sour; or the tiny Pacific island of Nauru through a Coffee Pineapple Old Fashioned.

Accompanied by illustrations of the cocktails and maps of each continent, this book is an exhaustively comprehensive, extensively researched, uniquely lively, and informative addition to any cocktail library—perfect for novice or seasoned mixologists and world history buffs alike.

Contributor Bio

Chris Vola, a graduate of the Columbia University MFA Writing Program, was formerly the head bartender at New York City's neo-speakeasy Little Branch, where he trained under the late cocktail pioneer Sasha Petraske. In addition to a short story collection, a poetry collection, and two novels, he is the author of *Cheers to Today: 365 Cocktails Because Every Day Is a Holiday* (2022), *Pour One Out: Cocktail Odes to TV's Most Dearly Departed* (2019) and *I is for Illuminati: An A-Z Guide to Our Paranoid Times* (2020). His writings about drinks, literature, food, and pop culture have appeared in print and online journals, including *The Brooklyn Rail*, *Thrillist*, *Supercall*, and *Timothy McSweeney's Internet Tendency*. He lives in New York City.

Marketing Plans

- Select events and book signings
- National print and online publicity campaign
- Review copy mailings to food and drink editors at daily newspapers and men's, women's, and food and drink magazines, as well as popular websites and verticals
- Pitch for podcast interviews
- Digital consumer advertising campaign
- Social media promotions across @unionsqandco channels

Union Square & Co.
9781454952404
1454952407
Pub Date: 10/22/2024
On Sale Date: 10/22/2024
\$40.00/\$52.00 Can./£30.00 UK
Discount Code: T
Hardcover

304 Pages
100 color line art illus., including 7 maps
Carton Qty: 5
Print Run: 30K
Cooking / Beverages
CKB006000
Territory: World
10.9 in H | 9.1 in W
Status: **ACTIVE**

Related Products

Ebooks

9781454952411

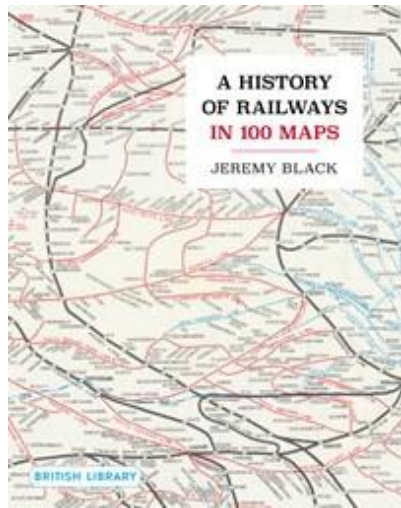

9780712355018
0712355014
Pub Date: 10/10/2024
On Sale Date: 10/10/2024
Ship Date: 10/10/2024
£40.00 UK
Hardcover

HBTP1
27.9 cm H | 22.1 cm W
Status: **ACTIVE**

A History of Railways in 100 Maps

Jeremy Black

Continuing the thematic strand of the successful and proven British Library '100 Maps' series. This new volume traces the fully international history of railways from their beginnings in the north-west of England through to the inter-continental lines of today.

Summary

Continuing the thematic strand of the successful and proven British Library '100 Maps' series, this new volume traces the fully international history of railways from their beginnings in the north-west of England through to the inter-continental lines of today.

Arranged chronologically, and with some 140 newly photographed maps and ephemera from the British Library's cartographic holdings, *A History of Railways in 100 Maps* explores both the progress of the railways and railway infrastructure across the globe, and through mountains, deserts, cities and even under oceans. The volume also charts the development of how railways were surveyed and presented in two- and three-dimensional forms for the purposes of engineering and construction, politics, economics and indeed war.

A dedicated chapter looks at fantasy and literary railway maps, while the book concludes with a presentation of recent breakthroughs in railway infrastructure, design and mapping and also looks ahead to future developments in this most lasting of transport inventions.

Contributor Bio

Jeremy Black, internationally known historian and Professor of History at the University of Exeter, is the author of *The Cold War: A Military History*, *Rethinking World War Two: The Conflict and its Legacy* and *Metropolis: Mapping the City*, among many others. He is also a keen writer on maps and their history and is the author of the award-winning *The History of the Second World War in 100 Maps* (British Library 2020) which was selected as the year's Best Reference Pick by the *Library Journal* in 2020.

Illustrations

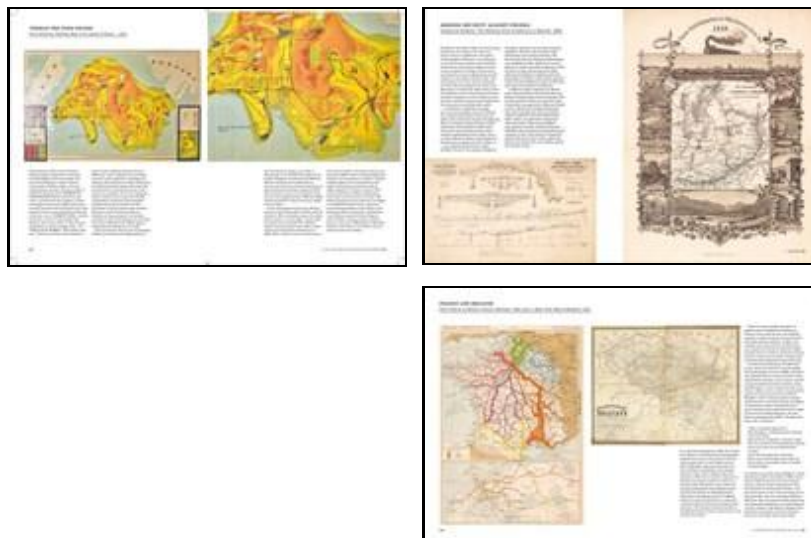

Comp Titles

No comparable titles have been specified.

Subrights

No subrights have been specified.

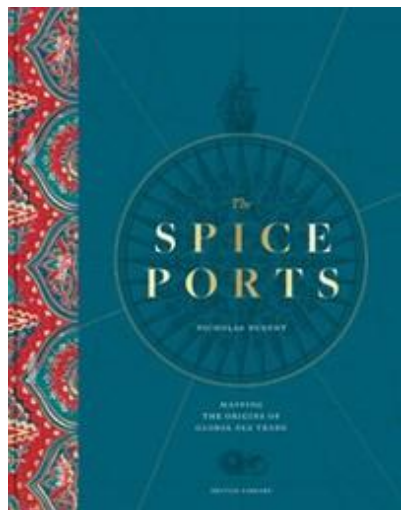

9780712355957

0712355952

Pub Date: 19/09/2024

On Sale Date: 19/09/2024

Ship Date: 19/09/2024

£40.00 UK

Hardcover

HBTM

27.9 cm H | 22.1 cm W

Status: **ACTIVE**

The Spice Ports

Mapping the Origins of Global Sea Trade

Key Selling Points

- This wide-ranging account of a fascinating period of global history uses original maps and contemporary artists' views to tell the story of how each port developed individually
- Powerful tales are presented alongside some of the most exquisite examples of art to survive from the eighth to the sixteenth centuries

A first-class narrative writer blends his unique cartographic and topographic understanding of the key ports of early seaborne commerce.

Summary

We may think of 'globalism' as a recent development, but its origins date back to century and beyond, when courageous seafarers pioneered routes across the oceans with the objectives of exploration, trade and profits.

Improvements in ship design, compasses and mapping, enabled navigation across unprecedented distances. The embarkation points were the vibrant ports of the West – Venice, Amsterdam, Lisbon – and their destinations the exotic ports of the East – Malacca, Goa, Bombay – where they tracked down the elusive spices.

This development of maritime communication brought benefits apart from culinary delights: the spread of ideas on art, literature and science. But it was not necessarily beneficial for everyone concerned: colonial ambitions could be disastrous for local populations, often exploited as labour.

This wide-ranging account of a fascinating period of global history uses original maps and contemporary artists' views to tell the story of how each port developed individually; while encouraging us to consider contrasting points of view of the benefits and the damages of the maritime spice trade.

Contributor Bio

Nicholas Nugent spent his career as a journalist with the BBC World Service, and his spare time collecting a valuable archive of original maps, and thus developed a passion for how the growth of the spice ports helped spread the exchange of global culture between East and West.

Illustrations



Comp Titles

No comparable titles have been specified.



9780712354318
 071235431X
 Pub Date: 19/05/2022
 Ship Date: 19/05/2022
 £16.99 UK
 Hardcover

144 Pages
 60 Illustration(s)
 JPVN

21.6 cm H | 15.1 cm W
 Status: **ACTIVE**

The Story of Propaganda in 50 Images

David Welch

Key Selling Points

- Explores the origins and development of visual, psychological and political communication from Trajan to Trump and asks what comes next? Are we *all* propagandists now?
- Illustrated in full colour with 50 powerful, eye-opening and provocative images which reveal propaganda's significance as an intrinsic and increasingly pervasive part of our daily experience.
- Written by one of the world's leading writers on all forms of propaganda and including a wide range of printed and digital material collected by the British Library. In this timely and fully international book, David Welch has selected fifty images to highlight the continuities and dis-continuities of mass-communication throughout history, be they via images, events, films or by 'propaganda by deed'.

Summary

Propaganda is thousands of years old. But it came of age in the 20th century, when the development of mass media (and later multimedia communications) offered a fertile ground for its dissemination, and the century's global conflicts provided the impetus needed for its growth. Put simply, propaganda is the dissemination of ideas intended to convince people to think and act in a particular way and for a particular persuasive purpose. But it takes many forms, is fluid and indeed is constantly developing, most fervently in our own digital era. Terms such as 'fake news', 'post-truth', 'gate-keepers' and 'asymmetrical warfare' were unknown a decade ago yet today are now commonplace, and often cynically derided, in daily media communications.

In this timely and fully international book, David Welch has selected fifty images to highlight the continuities and dis-continuities of mass-communication throughout history, be they via images, events, films or by 'propaganda by deed'. Such an approach demonstrates how changing technological innovations (such as television and the internet) have continued to shape the propaganda narrative but also demonstrate how tried and trusted forms of propaganda – such as the humble leaflet – can still prove highly effective. The fifty images included are not all necessarily the most striking – rather they have been chosen because they illustrate recurring themes and devices (such as humour) and different mediums employed by propagandists – from early Egyptian coins eulogizing Alexander the Great to the psychological warfare used in the war against terrorism following the destruction of the Twin Towers in New York, and the use of social media employed so widely in the current Covid pandemic.

Contributor Bio

David Welch is Emeritus Professor of Modern History and Honorary Director of the Centre for the Study of War, Propaganda & Society at the University of Kent. He has published many books on propaganda including *Persuading the People: British Propaganda in World War II*; *Germany and Propaganda in World War I*; *The Third Reich: Politics and Propaganda*; *Propaganda: Power and Persuasion* and *Protecting the People: The Central Office of Information and the Reshaping of Post-War Britain, 1946–2011*. In 2019 a special Festschrift was published by Bloomsbury honouring his contribution to the field of propaganda studies.

Comp Titles

No comparable titles have been specified.

Subrights

No subrights have been specified.

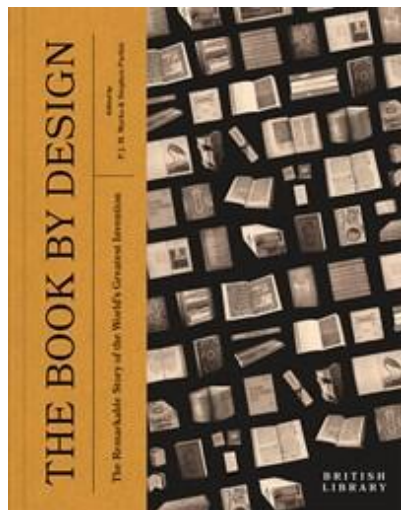

British Library Publishing
9780712354042
0712354042
Pub Date: 28/09/2023
Ship Date: 28/09/2023
£40.00 UK
Hardcover

288 Pages
Colour illustrations throughout
AC
26.4 cm H | 20.6 cm W
Status: **ACTIVE**

The Book by Design

The Remarkable Story of the World's Greatest Invention

P J M Marks, Stephen Parkin

Key Selling Points

- Based around 20 significant items in the Library's collections, this new publication traces major moments in the history of this remarkable invention
- Includes famous examples, such as the Lindisfarne Gospels and The Grammar of Ornament as well as lesser-known formats such as Southeast Asian palm leaf books and Russian futurist wallpaper books
- An essential addition to the personal library of anyone passionate about books and their design

This is a fascinating exploration of the development of book design through some of the most treasured volumes in the British Library collections.

Summary

Why does a book look and feel the way it does? What can it tell us about the circumstances of its creation? This is a fascinating exploration of the development of book design through some of the most treasured volumes in the British Library collections. Carefully selected by the Library's curatorial teams and beautifully illustrated with striking new studio photography alongside images from specially digitised collections, *The Book by Design* includes:

The Lindisfarne Gospels • The Diamond Sutra of 868 The Arnstein Bible • The Golden Haggadah The Queen Mary Psalter • The Mainz Psalter of 1457 Hypnerotomachia Poliphili • Akbar's Khamsah of Nizami • The Shakespeare First Folio • Tale of Genji • A Qur'an from Aceh • The Grammar of Ornament • The Buddha's Last Birth Tale • Audubon's The Birds of America • The Works of Geoffrey Chaucer

Flowing between these major chapters are features covering unusual book formats, interesting bindings and materials, as well as particular design elements and trends from different periods and cultures. This structure brings together works of historical importance and modern innovation to create a volume that will delight bibliophiles and anyone passionate about book design and production.

Contributor Bio

P J M Marks is Curator of Bookbindings. **Stephen Parkin** is Curator of Printed Heritage Collections 1450–1600, and a specialist in early printing in Italy.

Comp Titles

No comparable titles have been specified.

Subrights

No subrights have been specified.

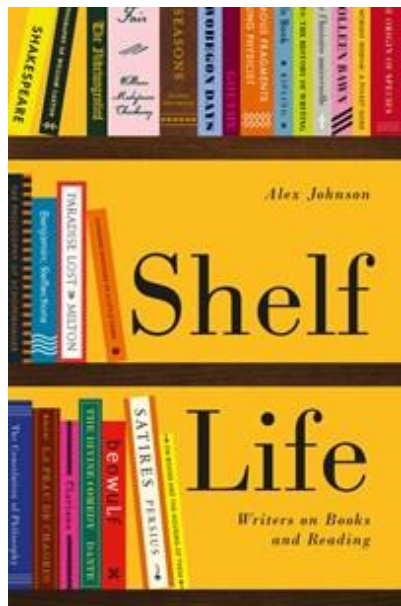

BRITISH LIBRARY
9780712352864
0712352864
Pub Date: 11/10/2018
\$16.95/\$22.95 Can./£10.00 UK
Paperback

128 Pages
Carton Qty: 52
DSRC
19.1 cm H | 13.3 cm W | 1.5 cm T
| 208.7 g Wt
Status: **ACTIVE**

Shelf Life

Writers on Books and Reading

Alex Johnson

The many facets of book-mania are pondered and celebrated with both sincerity and irreverence in this lively selection of essays, poems, lectures and commentaries ranging from the 16th to the 20th century.

Summary

Books; reading, collecting and the physical housing of them has brought the book-lover joy - and stress - for centuries. Fascinated writers have tried to capture the particular relationships we form with our library, and the desperate troubles we will undergo to preserve it. With Alex Johnson as your guide, immerse yourself in this eclectic anthology and hear from an iconic Prime Minister musing over the best way to store your books and an illustrious US President explaining the best works to read outdoors. Enjoy serious speculations on the psychological implications of reading from a 19th century philosopher, and less serious ones concerning the predicament of dispensing with unwanted volumes or the danger of letting children (the 'enemies of books') near your collection. The many facets of book-mania are pondered and celebrated with both sincerity and irreverence in this lively selection of essays, poems, lectures and commentaries ranging from the 16th to the 20th century.

Contributor Bio

Alex Johnson is a freelance journalist. His books include *Improbable Libraries*, *A Book of Book Lists*, *Book Towns*, *Shelf Life* and *Edward Lear and the Pussycat: Famous Writers and their Pets*.

Table Of Contents

The Enemies of Books by William Blades (1881) Unpacking my library by Walter Benjamin (1931) A Lesson in Fiction by Stephen Leacock (1910) Detached Thoughts on Books and Reading by Charles Lamb (1822) Books for Holidays in the Open by Theodore Roosevelt (1916) Bibliomania by John Ferriar (1809) The Uses of Reading by Rudyard Kipling (1912) On Reading and Books by Arthur Schopenhauer (1851) On books and the housing of them by W.E. Gladstone (1890) Of Studies by Francis Bacon (1601) On Destroying Books (1919)

Illustrations

Contents			
Introduction	1	Bibliomania # John Ferriar (1809)	67
The Enemies of Books # William Blades (1881)	5	<i>A poem about the delights (and dangers) of enjoying the printed word.</i>	
Unpacking my Library # Walter Benjamin (1931)	11	The Uses of Reading # Rudyard Kipling (1912)	79
A Lesson in Fiction # Stephen Leacock (1910)	27	<i>Why books are necessary for leading a good life.</i>	
Detached Thoughts on Books and Reading # Charles Lamb (1822)	37	On Reading and Books # Arthur Schopenhauer (1851)	105
Books for Holidays in the Open # Theodore Roosevelt (1916)	51	<i>How and who not to read.</i>	
		On Books and the Housing of Them # W.E. Gladstone (1890)	121
		<i>Prime Ministerial advice on how to store one's library properly.</i>	
		Of Studies # Francis Bacon (1601)	149
		<i>Bring an explanation of the ways in which books makeh man.</i>	
		On Destroying Books # J.C. Squire (1919)	155
		<i>An extreme way to decorate your library.</i>	



British Library Publishing
9780712354943
0712354948
Pub Date: 16/05/2024
On Sale Date: 16/05/2024
Ship Date: 16/05/2024
\$29.99/\$39.99 Can./£18.99 UK
Hardcover

224 Pages
Carton Qty: 20
WTL
21 cm H | 15.2 cm W
Status: **ACTIVE**

The Book Lover's European Bucket List

A Grand Tour of Literature

Caroline Taggart

Key Selling Points

- Contains 100 literary landmarks across Europe
- Follows the success of Caroline's previous title *The Book Lover's Bucket List* (2021)
- Accompanied by colour destination photographs and illustrations, mainly from the British Library Collection

Accompanied by colour destination photographs and illustrations, mainly from the British Library Collections, this book is sure to inspire real travel and vicarious vacations alike.

Summary

Following the success of *The Book Lover's Bucket List*, Caroline Taggart sets off on a tour of Europe to select 100 literary landmarks across the continent to describe and provide practical advice for visiting. Discover the inspirations in Austria for Mary Shelly and in Sweden for Astrid Lindgren; visit Cervantes' statue in Madrid dating back to 1835 and explore the French Riviera through the eyes of F. Scott Fitzgerald.

The entries stretch from Homer in the eighth century BCE all the way to modern-day Scandi Noir, Sally Rooney's Dublin and Elena Ferrante's Naples.

Accompanied by colour destination photographs and illustrations, mainly from the British Library Collections, this book is sure to inspire real travel and vicarious vacations alike. Lose yourself in the Venice of Thomas Mann, Edith Wharton and Donna Leon, then retreat by train to the romantic streets of Verona in search of Romeo and Juliet.

Contributor Bio

Caroline Taggart worked in publishing as an editor of popular non-fiction for thirty years before writing *I Used to Know That*, which became a Sunday Times bestseller. Her other books include *The Book of English Place Names*, *A Slice of Britain: Around the Country by Cake* and *The Book Lover's Bucket List*, which was published by the British Library in 2021.

Illustrations



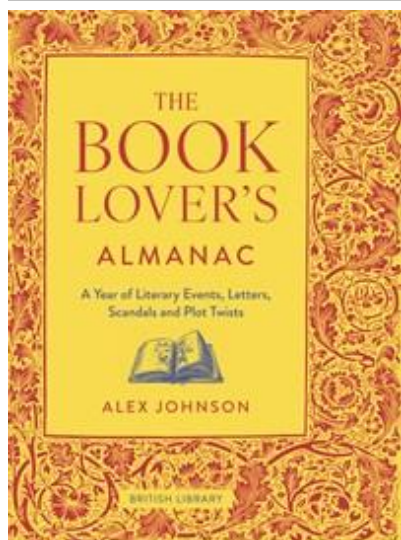

British Library Publishing
9780712354240
0712354247
Pub Date: 5/10/2023
Ship Date: 5/10/2023
\$29.99/\$39.99 Can./£19.99 UK
Hardcover

296 Pages
Colour illustrations throughout
Carton Qty: 16
GBCY

21 cm H | 15.2 cm W | 2.8 cm T |
721.2 g Wt
Status: **ACTIVE**

The Book Lover's Almanac

A Year of Literary Events, Letters, Scandals and Plot Twists

Alex Johnson

Key Selling Points

- Mark the passing of the days with this delightfully illustrated Almanac
- Draws on the vast collections of the British Library to find new, surprising and entertaining ways to celebrate each day

Enjoy daily distraction with this engaging Almanac.

Summary

Enjoy daily distraction with this engaging Almanac. Each date is assigned one or more literary connections. Book lovers will find extracts from authors' diaries and letters, chance upon the narrative twists and transformative moments in their favourite novels, discover the winners of prestigious awards and losers of creative squabbles, and the delivery of manuscript, first publication and performance.

The book draws on the incredible collections of the British Library to find new, surprising and entertaining ways to celebrate every day of the year. Each month opens with a list of significant births and closes with a selection of pertinent last words, while entries roam across history from the great classics to modern authors.

Contributor Bio

Alex Johnson is a freelance journalist. His books include *Improbable Libraries*, *A Book of Book Lists*, *Book Towns*, *Shelf Life* and *Edward Lear and the Pussycat: Famous Writers and their Pets*.

Illustrations



Comp Titles

Edward Lear and the Pussycat	Johnson, Alex	BRITISH LIBRARY	22/08/2019	9780712352444	£9.99	Book
				0712352449	GBP	
How To Give Your Child A Lifelong Love Of Reading	Johnson, Alex	BRITISH LIBRARY	26/03/2020	9780712353854	£12.99	Paperback
				0712353852	GBP	
The Book Lover's Joke Book	Johnson, Alex	British Library Publishing	13/10/2022	9780712354516	£9.99	Hardcover
				0712354514	GBP	
Shelf Life		BRITISH LIBRARY	11/10/2018	9780712352864	£10.00	Paperback
				0712352864	GBP	
A Book of Book Lists	Johnson, Alex	BRITISH LIBRARY	18/10/2017	9780712352253	£9.99	Paperback
				0712352252	GBP	

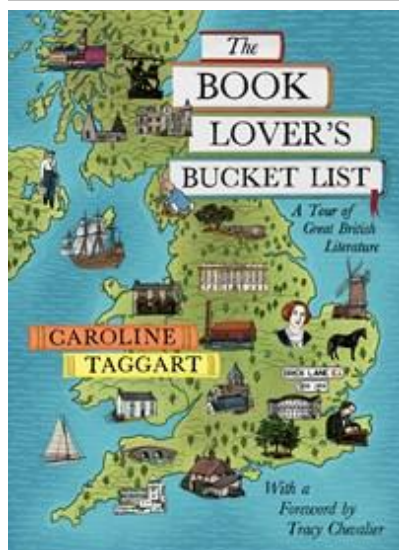

British Library Publishing
 9780712353243
 0712353240
 Pub Date: 17/06/2021
 Ship Date: 17/06/2021
 \$27.99/\$37.99 Can./£16.99 UK
 Hardcover

224 Pages
 Carton Qty: 16
 WTL
 Series: Philosophies
 21 cm H | 15.2 cm W | 2 cm T |
 576.1 g Wt
 Status: **ACTIVE**

The Book Lover's Bucket List

A Tour of Great British Literature

Caroline Taggart, Tracy Chevalier

Key Selling Points

- Foreword from bestselling author Tracy Chevalier (*Girl with a Pearl Earring, The Virgin Blue, A Single Thread*)
- Walk along Monica Ali's *Brick Lane*, try to push a trolley through the wall of Platform 93/4 at King's Cross Station, visit Beatrix Potter's Lake District and Robert Louis Stevenson's Edinburgh, or explore the Roald Dahl museum
- Take a walking tour of Birmingham where J.R.R. Tolkien grew up, and whose industrial smoky air inspired the hellscape of Mordor.
- Visit the University of London's Senate House, whose imposing Art Deco architecture served as the real-life inspiration behind George Orwell's Ministry of Truth.
- Color destination photographs and illustrations from the British Library collections
- Caroline Taggart is the bestselling author of *I Used to Know That*

With a foreword by Tracy Chevalier

You can start in Cornwall and work your way up to the Gateway to the Scottish Highlands, taking detours to Northern Ireland in the west and Norfolk in the east. Or you can drop in on spec on the place nearest to you. Wherever you are in the United Kingdom, you're never far from something associated with a good book.

Summary

With a foreword by Tracy Chevalier

Start with Chaucer, Dickens, Blake and Larkin in Westminster Abbey. Hop on a bus through Zadie Smith's North London or spend an afternoon at Colliers Wood Nature Reserve in Nottinghamshire and look at the lake 'all grey and visionary, stretching into the moist, translucent vista of trees and meadow' that D. H. Lawrence described in *Women in Love*. Come back to London to walk along Monica Ali's *Brick Lane* and try to push a trolley through the wall of Platform 93/4 at King's Cross Station.

From the Brontë parsonage in Haworth to Waugh's Castle Howard; from Beatrix Potter's Lake District, Shakespeare's Stratford and Robert Louis Stevenson's Edinburgh, there are gardens, monuments, museums, churches and a surprising quantity of stained glass. There are walks both urban and rural, where you can explore real landscapes or imaginary haberdasher's shops. There's the club where Buck's Fizz was invented and a pub where you can eat Sherlock's Steak & Ale Pie. And there's a railway station where you can stroke the muzzle of one of the world's most famous and endearing bears.

You can start in Cornwall and work your way up to the Gateway to the Scottish Highlands, taking detours to Northern Ireland in the west and Norfolk in the east. Or you can drop in on spec on the place nearest to you. Wherever you are in the United Kingdom, you're never far from something associated with a good book.

Contributor Bio

Caroline Taggart worked in publishing as an editor of popular non-fiction for 30 years before writing *I Used to Know That*, which became a Sunday Times bestseller. Her other books include *The Book of English Place Names*, *The Book of London Place Names*, *How to Greet the Queen (And Other Questions of Modern Etiquette)*, and *A Slice of Britain: Around the Country by Cake*.

Illustrations

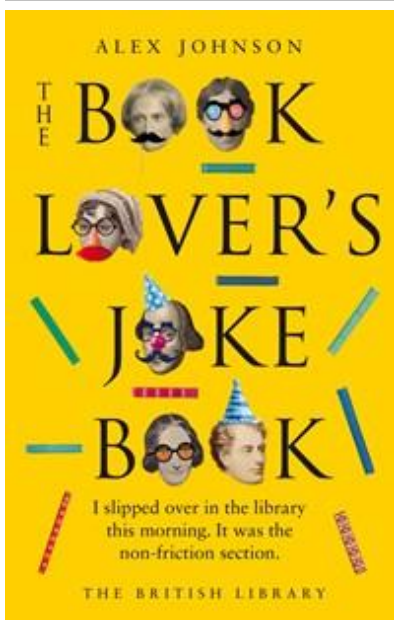

British Library Publishing
9780712354516
0712354514
Pub Date: 13/10/2022
On Sale Date: 13/10/2022
Ship Date: 13/10/2022
\$16.99/\$22.99 Can./£9.99 UK
Hardcover

288 Pages
Carton Qty: 40
WHJ
19.7 cm H | 12.7 cm W | 1.5 cm T
| 313 g Wt
Status: **ACTIVE**

The Book Lover's Joke Book

Alex Johnson

Key Selling Points

- Includes a huge range of comic material concentrating exclusively on the themes of books, reading, libraries, bookshops, and the literary life.
- One-liners, puns, knock-knock jokes, and shaggy dog stories, and much more.

This delightful literary celebration will make every bibliophile laugh out loud, even in the library.

Summary

The Book Lover's Joke Book is the funniest book about books you'll ever read. You'll find jokes about writers, agents, publishers, librarians, grammar, poetry, bookcases, and lightbulbs. There are rib-ticklers for typographers, crackers for critics, and badly foxed quips about antiquarian bookshops. Here too are the best literary April Fool's (the joke's on you), rejection letters (the joke's on the publisher), cookbook jests (the joke's a bit crumby) and wardrobe puns (the joke's Narnia business). This delightful literary celebration will make every bibliophile laugh out loud, even in the library.

I love telling people spoilers about The Picture of Dorian Gray.

Never gets old.

Why does Wally always wear a stripey shirt?

Because he doesn't want to be spotted.

What's the difference between Romeo and Juliet and COVID-19?

One's a coronavirus and the other's a Verona crisis.

Who was JRR Tolkien's favourite singer?

Elvish Presley

"Your diary is really good," said his wife.

"My thoughts exactly," replied Samuel Pepys.

Contributor Bio

Alex Johnson is a freelance journalist. His books include *Improbable Libraries*, *A Book of Book Lists*, *Book Towns*, *Shelf Life* and *Edward Lear and the Pussycat: Famous Writers and their Pets*.

Marketing Plans

- Chosen as part of IPG's Top Shelf program for Spring 2023
- Part of Top Shelf ads in *PW Daily* and *Shelf Awareness Pro*
- Inclusion in IPG's Top Shelf booklet, available in the January ABA Box and at winter and spring trade shows, including ABA Winter Institute, ALA LibLearnX (LLX), Texas Library Assoc Conference (TLA), and for Gift & specialty buyers at New York Now (NYNow)
- Digital Review Copy (DRC) uploaded to Edelweiss for buyers & customers
- Inclusion in the [Top Shelf Edelweiss catalog](#)
- Coordinated promotion(s) with publisher and author on IPG's social media channels, tagged with #IPGTopShelf, including Author Q&A (where applicable)
- Dedicated email campaign to IPG's bookseller list
- Dedicated email to librarian lists
- Dedicated email to IPG's consumer list
- Featured mention during sales account & librarian presentations throughout the

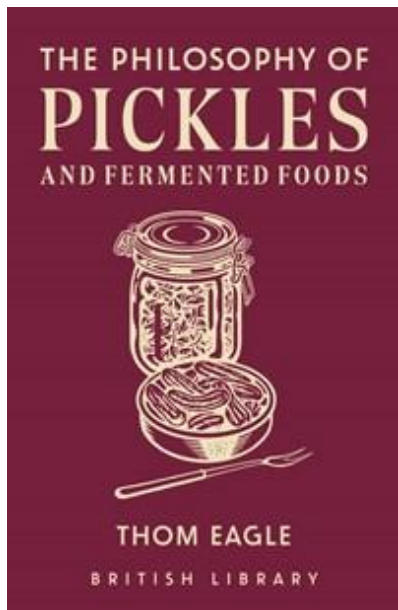

The The Philosophy of Pickles and Fermented Foods

Thom Eagle

A cultural history of pickling and fermentation for enthusiasts and a great general introduction for those who are curious to understand more about these food types and techniques. An excellent accompaniment for those who are looking to explore gut health and the microbiome.

Summary

Fermented food is playing a significant role in the developing discussion around gut health and the microbiome. More than the latest health trend, pickling and fermentation are techniques that have been used by human populations across the globe in food preparation for millennia. And they are part of a region's cultural heritage, passed from generation to generation, whether it's the Korean *kimjang* – the making and sharing of kimchi – the Japanese preparation of the *nukadoko* or pickling bed, or the brine-fermented fruits and vegetables of Georgia. Thom Eagle celebrates this fascinating history, explaining the different techniques and offering practical advice for enthusiasts.

Contributor Bio

Thom Eagle is one of the UK's leading voices on food and fermentation. He has presented at the Oxford Symposium of Food and Cookery on fermentation as a method of reducing food waste, consulted on various food preservation techniques, and headed up the opening team of Dalston's Littleduck, a restaurant and wholesale fermenting kitchen. He is the author of two books on cooking and preservation, *Summer's Lease* and the award-winning *First, Catch* and has written extensively on the subject for publications including *Vittles*, *National Geographic Food* and *Locavore*, with other writing appearing in the *Independent* and the *Telegraph*.



9780712355216
0712355219
Pub Date: 12/09/2024
Ship Date: 12/09/2024
£10.00 UK
Hardcover

0 Pages
30 black and white illustrations
WBW
Series: Philosophies
20 cm H | 13 cm W
Status: **ACTIVE**

Comp Titles

No comparable titles have been specified.

Subrights

No subrights have been specified.

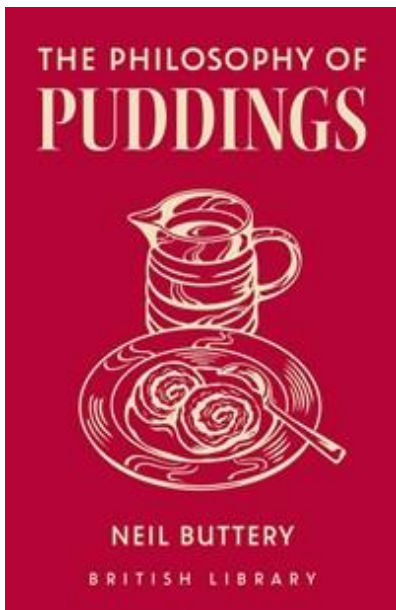

The The Philosophy of Puddings

Neil Buttery

Since the pandemic, sales of puddings are up 20% overall: rice pudding sales are up by 45%; Yorkshire pudding by 80%. This book that explores pudding's enduring popularity and why puddings remain the ultimate comfort food. Written by a chef, this is a thorough cultural history of the pudding in all its incarnations.

Summary

Just what is a pudding? We all have our favourites, whether it is a school-dinner jam roly-poly with custard, or a Yorkshire pud with onion gravy, a Burns' Night haggis or the Christmas plum pudding. The humble pudding started out as a savoury meal boiled in either animal intestine or in a cloth. With the advent of pudding bowls and moulds the pudding assumed a myriad of identities. Neil Buttery traces the long history of pudding and its importance in British culture and language. He has tried and tested many recipes from across the centuries in his 'Pud Club' and shares his extensive knowledge and expertise.

Contributor Bio

Neil Buttery is a food historian, chef and writer who has been obsessed with historical and traditional British food since he began writing his food blogs in 2007. A former restaurant owner, in the last few years he has focused on research for his blog, *British Food: A History*, and his books. His first publication, *A Dark History of Sugar*, was published in 2022, and his second, *Before Mrs Beeton*, was published in 2023. In 2022 he started interviewing other food historians for the popular *British Food History Podcast*.



9780712355117
0712355111
Pub Date: 24/10/2024
Ship Date: 24/10/2024
£10.00 UK
Hardcover

0 Pages
30 black and white illustrations
WBA
Series: Philosophies
20 cm H | 13 cm W
Status: **ACTIVE**

Comp Titles

No comparable titles have been specified.

Subrights

No subrights have been specified.

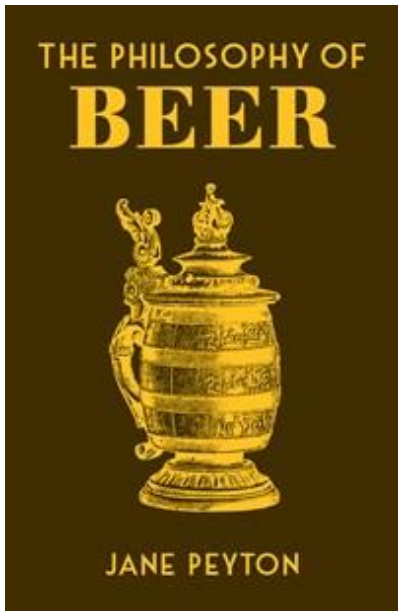

The Philosophy of Beer

Jane Peyton

Key Selling Points

- Become a mastermind in beer with practical advice on brewing and tasting from Britain's first ever Beer Sommelier of the Year
- An astonishing history of the beverage from 13,000-year-old evidence of beer's existence to its widespread enjoyment today, full of anecdotes to impress beer connoisseurs
- Continues a growing British Library series of popular drink- related Philosophies on coffee, tea, wine and gin

In *The Philosophy of Beer*, Jane Peyton, the UK's first Beer Sommelier of the Year, distils practical advice from the incredible history of the nation's favourite beverage, spanning the earliest evidence of beer 13,000 years ago, its central role in monasteries and on naval ships, its significance in the discovery of cholera, and its enduring popularity today.

Summary

Have you ever wondered about the difference between a lager and an ale? Or marvelled at how, with only four basic ingredients, there are around 150 different styles of beer?

In *The Philosophy of Beer*, Jane Peyton, the UK's first Beer Sommelier of the Year, distils practical advice from the incredible history of the nation's favourite beverage, spanning the earliest evidence of beer 13,000 years ago, its central role in monasteries and on naval ships, its significance in the discovery of cholera, and its enduring popularity today. This fascinating insight into beer's rich history will teach you how to taste like a professional, how best to match beer with food, and even how to brew it yourself! Quench your thirst for knowledge with everything you need to know to be a mastermind in beer.

Contributor Bio

Jane Peyton is an award-winning writer and alcoholic drinks expert. She is the UK's first accredited Pommelier (cider sommelier) and Principal of the School of Booze. Jane is also the author of a number of books including *The Philosophy of Gin*, published by the British Library in May 2020.

Illustrations



British Library Publishing
 9780712353472
 071235347X
 Pub Date: 8/04/2021
 Ship Date: 8/04/2021
 \$16.95/\$22.95 Can./£10.00 UK
 Hardcover
 112 Pages
 30 black and white illustrations
 Carton Qty: 40
 WBXD2
 Series: Philosophies
 20.3 cm H | 12.7 cm W | 1.3 cm T
 | 213.2 g Wt
 Status: **ACTIVE**

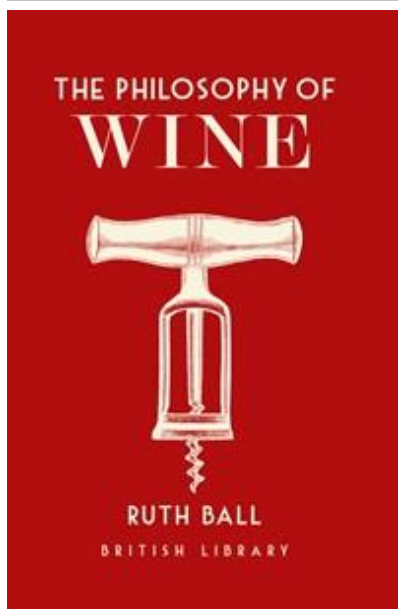

The Philosophy of Wine

Ruth Ball

Summary

An apt gift for oenophiles everywhere, this book includes chapters on the development of wine production, from the use of casks to bottles to the switch from feet to presses, as well as tracing the global shift of wine production from traditional wine-producing regions to emerging wine exporters. With a selective focus on unexpected facts and lesser-known characters connected with wine, from the Greek gods of wine to the monks who created Champagne and the ingenious ways French winemakers protected priceless vintages during wartime, this gift edition explores the historical influences that have shaped our drinking taste.

Contributor Bio

Ruth Ball is the author of *Rough Spirits and High Society* and the founder of Alchemist Dreams, a company dedicated to handmade liqueurs that are blended to order.

Illustrations



BRITISH LIBRARY
9780712352789
0712352783
Pub Date: 30/05/2019
\$16.95/\$22.95 Can./£10.00 UK
Book

112 Pages
Carton Qty: 52
WBXD1
Series: British Library Philosophy
of series
Territory: US, CA
19.7 cm H | 12.7 cm W | 1.3 cm T
| 217.7 g Wt
Status: **ACTIVE**

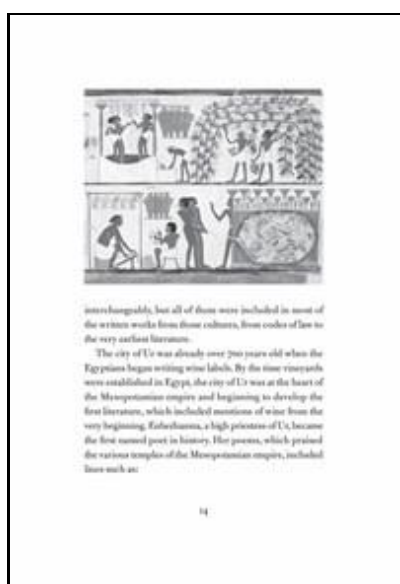
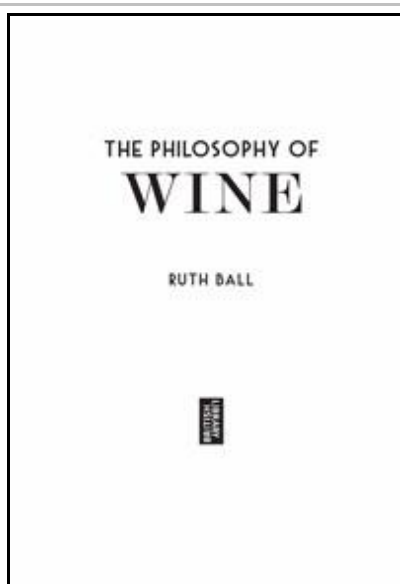

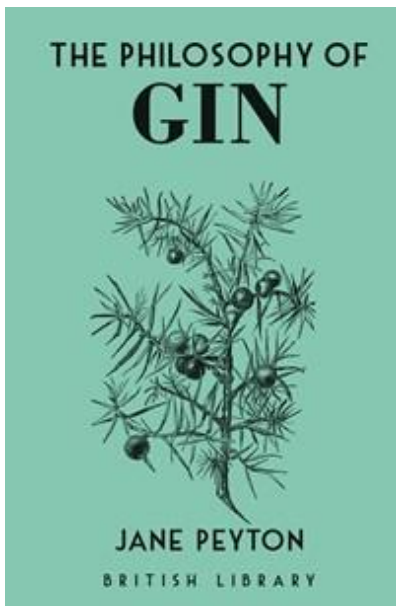

BRITISH LIBRARY
9780712353601
0712353607
Pub Date: 20/08/2020
Ship Date: 20/08/2020
\$16.99/\$22.99 Can./£10.00 UK
Hardcover

112 Pages
30 black and white illustrations
Carton Qty: 32
WBXD3
Series: Philosophies
20.3 cm H | 13.3 cm W | 1.5 cm T
| 276.7 g Wt
Status: **ACTIVE**

The Philosophy of Gin

Jane Peyton

Few if any alcoholic drinks have the dramatic and multi-faceted history of gin. This book explores how a spirit once given a wide berth by the middle and upper classes now attracts such a large proportion of the British public to choose gin as their tippie of choice.

Summary

Few if any alcoholic drinks have the dramatic and multi-faceted history of gin. In this fascinating new instalment of the British Library's pocket philosophies, gin is explored through its origins in Holland, where it was popularised by William of Orange; its roots in medicine; its capacity to provide an albeit destructive escapism during the Gin Craze; its influence on language - responsible for the coining of 'dutch courage'; and its current status as a popular social beverage and a pastime for those keen to experiment with flavouring their own gins.

The Philosophy of Gin covers the historic transformation of the beverage, ideal flavour pairings for the gin connoisseur, and how a spirit once given a wide berth by the middle and upper classes now attracts such a large proportion of the British public to choose gin as their tippie of choice.

Contributor Bio

Jane Peyton is an award-winning writer and alcoholic drinks expert, as well as Britain's First Accredited Pommelier (Cider Sommelier) and Principal of the School of Booze. She is the author of *Beer O'Clock*.

Table Of Contents

- Gintroduction
- Happily Ever After
- Meet Madam Geneva
- What the Doctor Ordered
- War is the Trade of Kings
- What's Your Poison?
- A Life on the Ocean's Wave
- Ring in the Changes
- Where's the Party?
- Queen Gin
- The Cocktail Menu
- Different Styles of Gin and Juniper Spirits
- Tips for the Perfect G & T
- Further Reading
- List of Illustrations

Illustrations

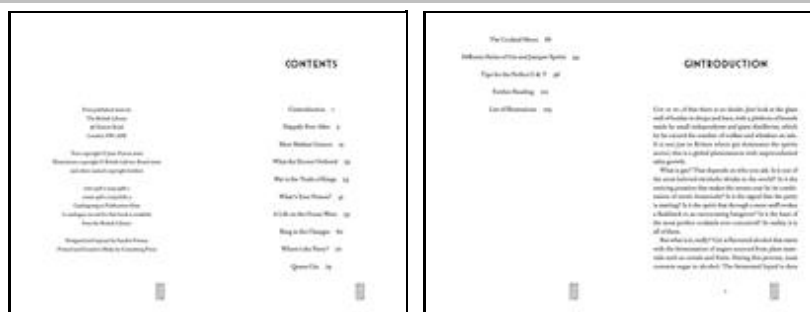

THE PHILOSOPHY OF CHOCOLATE



SAM BILTON

BRITISH LIBRARY



British Library Publishing
9780712354349
0712354344
Pub Date: 19/10/2023
Ship Date: 19/10/2023
\$16.99/\$22.99 Can./£10.00 UK
Hardcover

112 Pages
30 black and white illustrations
Carton Qty: 48
WBTX
Series: Philosophies
20.3 cm H | 12.7 cm W | 1.3 cm T
| 231.3 g Wt
Status: **ACTIVE**

The Philosophy of Chocolate

Sam Bilton

Key Selling Points

- Continues the strand of hugely popular food entries in the Philosophies series following *The Philosophy of Curry* (2022) and *The Philosophy of Cheese* (2020).
- Author Sam Bilton is a food historian and presenter of the *Comfortably Hungry* podcast
- Divided thematically, moving between ceremonial uses of chocolate and its reputed health properties to its production in the Americas and the exploitation of indigenous populations

Sam Bilton explores our complex relationship with this versatile confection, which is made from the humble beans of the tropical cacao tree.

Summary

What makes chocolate so alluring? Why is it the inspiration for endless culinary creativity? Sam Bilton explores our complex relationship with this versatile confection, which is made from the humble beans of the tropical cacao tree.

Divided thematically, the book moves between the ceremonial uses of chocolate and its reputation as an aphrodisiac, investigates its reputed health properties and poisonous possibilities. Other chapters reveal the darker side of its production in the Americas, through slave labour and exploitation of indigenous populations, as well as its commercialisation as a sweet treat in Western cultures, and chocolate consumption around the world.

This mouth-watering, illustrated book is rounded off with tasting tips and chocolate recipes to leave you feeling fully replete.

Contributor Bio

Sam Bilton is an author, food historian and presenter of the *Comfortably Hungry* podcast. She also provides cookery demonstrations, particularly on vintage cuisine, and appears on TV and radio.

Table Of Contents

Introduction
Spiritual Chocolate
Seductive Chocolate
Healthy Chocolate
Hospitable Chocolate
Feminine Chocolate
Romantic Chocolate
Poisonous Chocolate
Fraudulent Chocolate
Ethical Chocolate
Innovative Chocolate
How to Taste Chocolate
Glossary of Terms
Further Reading
List of Illustrations

Illustrations



BRITISH LIBRARY
9780712352307
0712352309
Pub Date: 19/01/2018
\$16.99/\$22.99 Can./£10.00 UK
Hardcover

80 Pages
15 illustrations
Carton Qty: 30
WBXN
Series: British Library Philosophy
of series
19.7 cm H | 13.3 cm W | 1.8 cm T
| 249.5 g Wt
Status: **ACTIVE**

The Philosophy of Coffee

Brian Williams

This is a short, entertaining and illuminating introduction to the history and culture of coffee, from the humble origins of the bean in northeast Africa over a millennium ago, to what it is today, a global phenomenon that is enjoyed around the world.

Summary

This is a short, entertaining and illuminating introduction to the history and culture of coffee, from the humble origins of the bean in northeast Africa over a millennium ago, to what it is today, a global phenomenon that is enjoyed around the world. It is the perfect gift for coffee lovers, including chapters on the rise of the coffeehouse, legal bans on coffee, Brazil's domination of the world coffee trade and the birth of the espresso.

Contributor Bio

Brian Williams blogs about the culture of coffee at Brian's Coffee Spot. This is his first book.

Quotes

"A beautifully illustrated guide to everything we could ever want to know about our morning cup of Joe." --Stylist

Table Of Contents

Contents

Introduction.....	1
The Origins of Coffee.....	3
What is Coffee?.....	6
The Wine of Islam.....	12
Coffee Reaches Europe.....	17
The Rise of the Coffeehouse.....	22
The Suppression of the Coffeehouse.....	28
Escape from Arabia.....	33
Coffee Spreads Around the World.....	37
The Rise of Brazil.....	41
The Rise and Fall of Coffee in Britain.....	45
The Boston Tea Party.....	49
The Nineteenth-Century Coffee Boom.....	53
The Birth of Espresso.....	59
The Italians and Post-War London.....	65
Friends and the Rise of the Modern Coffee shop.....	70
The Coffee Trade.....	74
Coffee, a Global Culture.....	78
Where Do We Go From Here?.....	82
Appendix 1	
But Doesn't All Coffee Taste the Same?.....	87
Appendix 2	
Brewing Coffee.....	91
Further Reading.....	97
Notes.....	101

Illustrations

THE PHILOSOPHY OF TEA



TONY GEBELY



British Library Publishing
9780712352598
0712352597
Pub Date: 1/03/2020
On Sale Date: 1/03/2020
\$16.99/\$22.99 Can./£10.00 UK
Hardcover

112 Pages
Carton Qty: 40
Cooking / Beverages
CKB019000
Series: British Library Philosophy
of series
21 cm H | 12.7 cm W | 1.3 cm T |
244.9 g Wt
Status: **ACTIVE**

The Philosophy of Tea

Tony Gebely

Summary

How did drinking the infusions of a unique plant from China become a vital part of everyday life? This gift book presents an entertaining and illuminating introduction to the history and culture of tea, from its origins in the Far East to the flavors and properties of different varieties, and the rituals of tea preparation and drinking around the world. This simple hot beverage is suffused with artistic and religious overtones. The Chinese Ch'a Ching gave very precise guidelines to the preparation and sipping of tea, and the Japanese tea ceremony elevated it to an art form. Following its introduction to the royal court in the 17th century, the British created their own traditions, from the elaborate etiquette of afternoon tea to the humble pot of tea at the heart of family life, and the modern appreciation for specialty infusions.

Contributor Bio

Tony Gebely is a tea enthusiast and expert. He is the author of *Tea: A User's Guide*, and the founder of the award-winning blog World of Tea.

Table Of Contents

The Journey Begins	1
What is Tea?	5
Six Types, One Plant	9
Green Tea	15
Yellow Tea	20
White Tea	22
Oolong Tea	24
Black Tea	29
Fermented Tea	35
The Origin of Tea	39
Tea by Sea, Cha by Land	43
Tea Infuses England	45
Chinese Tea Culture	53
Japanese Tea Culture	57
Indian Tea Culture	61
Sri Lankan Tea Culture	67
British Tea Culture	69
Moroccan Tea Culture	73
American Tea Culture	75
Preparing Tea	79
Tea and Health	87
Further Reading	93
Notes	95
List of Illustrations	101

Illustrations

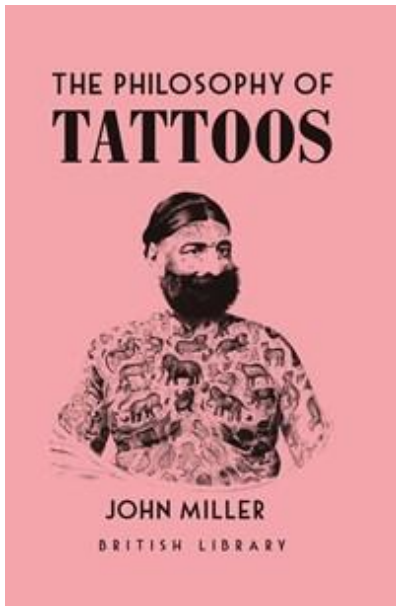

The Philosophy of Tattoos

John Miller

Key Selling Points

- Explores tattooing as an innate human impulse throughout history, following its suppression and revival in cultures around the world
- A bold and nuanced story of colonial oppression, social deviance and tattooing in the age of social media
- Features original tattoo designs from London-based tattoo artist Luca Ortis (64k followers on Instagram @lucaortis) as well as illustrations from the British Library collections

In this impressively broad yet personal account, John Miller – ‘a conventionally dressed middle-aged academic with a full bodysuit’ – explores tattooing as a unique expression of individual, cultural and national identity.

Summary

‘History, it seems, is seldom written by the tattooed.’

In this impressively broad yet personal account, John Miller – ‘a conventionally dressed middle-aged academic with a full bodysuit’ – explores tattooing as a unique expression of individual, cultural and national identity.

As the inherent shock factor of tattooing in the west decreases, tattoos are becoming more extensive, public and challenging in response, prompting an upsurge in ‘extreme’ tattooing. In an age of aesthetic obsession, the tattoo – once the ultimate symbol of deviance – is now as commodifiable as anything else.

Resisting this apparent loss of the ‘magic’ of tattooing, *The Philosophy of Tattoos* returns to its origins in cultural locations as disparate as Polynesia, the Amazon and the Arctic to interrogate the innate human desire to mark the skin. It asks what the history of tattooing might tell us about that fundamental question: what does it mean to be human?

Contributor Bio

John Miller is Senior Lecturer in Nineteenth-Century Literature at the University of Sheffield and editor of the classic fiction collection *Tales of the Tattooed*, published by the British Library in 2019.

Illustrations



British Library Publishing
 9780712353083
 0712353089
 Pub Date: 25/03/2021
 Ship Date: 25/03/2021
 \$16.95/\$22.95 Can./£10.00
 UK/€15.00 EU
 Hardcover

112 Pages
 30 black and white illustrations
 Carton Qty: 40
 AFY
 Series: Philosophies

20.3 cm H | 12.7 cm W | 1.3 cm T
 | 208.7 g Wt
 Status: **ACTIVE**



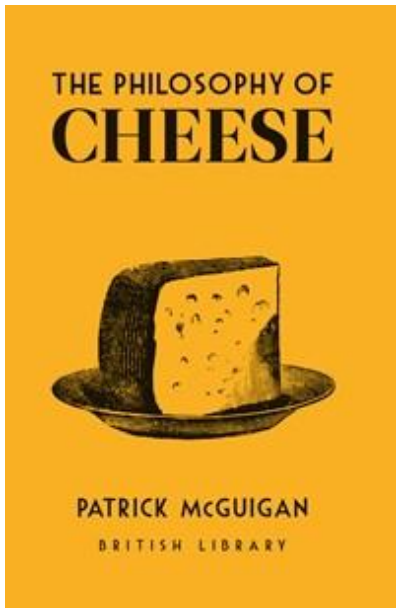

The Philosophy of Cheese

Patrick McGuigan

Key Selling Points

- A global approach to the rich history of cheese, throughout Europe and beyond
- The perfect gift for cheese slice lovers and artisan cheese connoisseurs alike
- Written by expert cheese writer, professional taster and cheese judge Patrick McGuigan

Summary

From the first cheese, dating to 5000 BC, food journalist Patrick McGuigan travels through Feta's relation to ancient faiths, the influence of monks on Munster, the rise of Roquefort and the global trade of Gouda. Discover how the household staple of Cheddar stands as a symbol for industrialization, and what Rogue River Blue can tell us about the artisan cheese renaissance happening in the US today. If you've ever looked at a cheese rind and wondered "Can I eat this?," *The Philosophy of Cheese* will set you right. Alongside surprising and little-known stories of much-loved cheeses, this book will teach you how to effectively store your cheese, how to pair it with alcohol for an exquisite tasting and how to create the cheeseboard of your dreams.

Contributor Bio

Patrick McGuigan is a British food journalist and cheese writer, who contributes to *The Telegraph*, *Delicious* and *The Financial Times*, among many other titles. He has traveled the world, from the Swiss Alps to the hipster cheese bars of New York, to write about cheese makers, maturers and retailers. A senior judge at the World Cheese Awards, Patrick also teaches cheese courses at the School of Fine Food and is a co-founder of the British Cheese Weekender and London Cheese Project festivals. He is particularly partial to a slice of Kirkham's Lancashire. www.patrickmcguigan.com

British Library Publishing
9780712353779
0712353771
Pub Date: 1/08/2021
\$16.95/\$22.95 Can./£10.00 UK
Hardcover

112 Pages
Carton Qty: 40
Series: Philosophies
20.3 cm H | 12.7 cm W | 1.3 cm T
| 204.1 g Wt
Status: **ACTIVE**

Illustrations



THE PHILOSOPHY OF CIDER



JANE PEYTON

BRITISH LIBRARY



British Library Publishing

9780712355056

0712355057

Pub Date: 13/06/2024

On Sale Date: 13/06/2024

Ship Date: 13/06/2024

\$16.99/\$22.99 Can./£10.00 UK

Hardcover

112 Pages

30 black and white illustrations

Carton Qty: 48

WBXD

Series: Philosophies

20.3 cm H | 12.7 cm W

Status: **ACTIVE**

The Philosophy of Cider

Jane Peyton

Key Selling Points

- Explore the journey of the apple from the foothills of Central Asia's Tien Shan mountains to the folk traditions of Britain
- Follows Jane's previous titles *The Philosophy of Gin* (2020), *The Philosophy of Beer* (2021) and *The Philosophy of Cocktails* (2023)
- Jane provides tasting tips and food pairings to help any aspiring cider drinker

In addition to explaining cider's links to champagne and why we are enjoying a renaissance of both cider- and perry-making, Jane provides tasting tips and food pairings to help any aspiring cider drinker. Welcome to Ciderland.

Summary

Cider is sunshine in a glass! Follow Jane Peyton on a glorious voyage of discovery, from the journey the wild *Malus Sieversii* apple – ancestor of today's domesticated apple – has made from the foothills of Central Asia's Tien Shan mountains, to the Norman invasion, which introduced new apple varieties and pressing technologies to Britain, to the colonists of America, who took apples with them, planted the seeds and drank cider long before beer brewing was properly established.

Today their legacy is sustained in the traditional orchards and processes of craft cider-makers; the folk traditions of the British Wassail and Txotx celebrations of the Basque Country; and the ethos of the Slow Food Movement.

In addition to explaining cider's links to champagne and why we are enjoying a renaissance of both cider- and perry-making, Jane provides tasting tips and food pairings to help any aspiring cider drinker. Welcome to Ciderland.

Contributor Bio

Jane Peyton is the UK's first accredited Pommelier (cider sommelier) and Principal of the School of Booze. She is an award-winning writer and, as an alcoholic drinks expert has also penned the *Gin*, *Cocktails* and *Beer* titles in *The Philosophy of...* series.

Quotes

The *Philosophy of Cider* is a book I wish had existed when I first began exploring the drink. Jane Peyton has done a marvellous job distilling the history and present of cider (and perry!) into this concise, incredibly user-friendly volume. The amount of detail she has included is fantastic, whilst her wonderfully approachable prose keeps it completely accessible to the modern reader. Having coined the term 'rethink cider' along with Susanna Forbes in 2018 Jane's role in the modern renaissance of cider's perception has been monumental, and she reports on its development diligently, unlocking the world of aspirational, high-juice-content cider to any new drinker lucky enough to come across this book. A recommended gift for any cider lover looking to learn about the drink and what makes it so wonderfully special.

Adam Wells, drinks writer and author of *Perry: A Drinker's Guide*

Unpublished Endorsements

The *Philosophy of Cider* is a book I wish had existed when I first began exploring the drink. Jane Peyton has done a marvellous job distilling the history and present of cider (and perry!) into this concise, incredibly user-friendly volume. The amount of detail she has included is fantastic, whilst her wonderfully approachable prose keeps it completely accessible to the modern reader. Having coined the term 'rethink cider' along with Susanna Forbes in 2018 Jane's role in the modern renaissance of cider's perception has been monumental, and she reports on its development diligently, unlocking the world

THE PHILOSOPHY OF COCKTAILS



JANE PEYTON
BRITISH LIBRARY



British Library Publishing
9780712354530
0712354530
Pub Date: 15/06/2023
Ship Date: 15/06/2023
\$16.99/\$22.99 Can./£10.00 UK
Hardcover

112 Pages
30 black and white illustrations
Carton Qty: 40
WBXD3
Series: Philosophies
20.3 cm H | 12.7 cm W | 1.3 cm T
| 249.5 g Wt
Status: **ACTIVE**

The Philosophy of Cocktails

Jane Peyton

Key Selling Points

- Explores the journey that cocktails have made, via China and the Middle East, the Americas and the UK
- Jane Peyton returns to the *Philosophy of...* series following *The Philosophy of gin* (2020) and *The Philosophy of Beer* (2021).
- Includes recipes and expert tips for making your favourite cocktails

This book explores the journey that cocktails have made, via China and the Middle East, the Americas and the UK, to arrive at the bespoke menus of today's stylish clubs and bars, complete with descriptions of the myriad ingredients, glassware and paraphernalia that the mixologist has at their disposal.

Summary

An early description of a cocktail as 'a mix of alcoholic drinks with flavouring ingredients' does nothing to convey the alchemy and speak-easy glamour of these elaborate drinks. The cocktail's humble beginnings as a medicinal tonic through the inclusion of botanicals into distilled spirits such as gin and whiskey, accelerates with the ingenuity of bartenders who created the 'classics' – the Martini, Manhattan and Old Fashioned – in the nineteenth-century, and in the decadence of the Jazz Age and Roaring Twenties.

This book explores the journey that cocktails have made, via China and the Middle East, the Americas and the UK, to arrive at the bespoke menus of today's stylish clubs and bars, complete with descriptions of the myriad ingredients, glassware and paraphernalia that the mixologist has at their disposal.

Contributor Bio

Jane Peyton is an award-winning writer and alcoholic drinks expert. She is the UK's first accredited Pommelier (cider sommelier) and Principal of the School of Booze. Jane is also the author of a number of books including two previous books in this series: *The Philosophy of Gin* (May 2020) and *The Philosophy of Beer* (2021).

Table Of Contents

- Introduction: The Drinks Cabinet
- In the Beginning
- Searching for Immortality
- Pick and Mix
- Old World to New World
- Mixing It Up
- The Golden Age
- Cocktails and Culture
- The Cocktail Menu
- Glossary of Terms
- Cocktail Formats
- Further Reading
- List of Illustrations

Illustrations

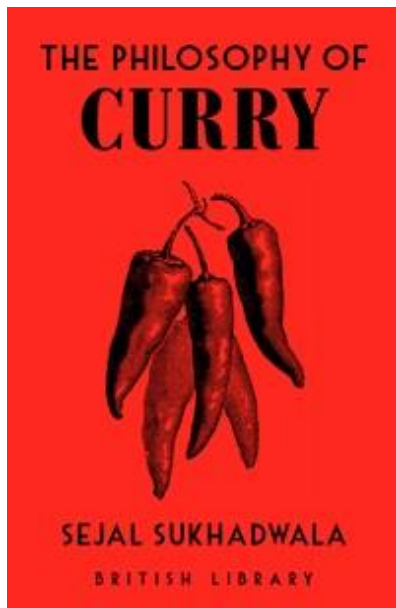

British Library Publishing
9780712354509
0712354506
Pub Date: 24/03/2022
Ship Date: 24/03/2022
\$16.95/\$22.95 Can./£10.00 UK
Hardcover

112 Pages
30 black and white illustrations
Carton Qty: 40
WBN
Series: Philosophies
20.3 cm H | 12.7 cm W | 1.3 cm T
| 231.3 g Wt
Status: **ACTIVE**

The Philosophy of Curry

Sejal Sukhadwala

Key Selling Points

- Author Sejal Sukhadwala has written for *BBC Good Food*, the *Guardian* and the *Metro*, among others.
- Helpful advice on which oils to use, how to temper spices and where to find those all-important mouth-watering recipes.
- Continues a growing British Library series of popular food & drink-related *Philosophies* on cheese, tea, beer and gin.

Sejal Sukhadwala probes the complex intersection of tradition and colonialism through the fascinating history of curry, from its association with Ayurveda – one of the world's oldest holistic healing systems to its enduring popularity in contemporary British culture.

Summary

There are curries on almost every continent, with a stunning diversity of flavours and textures across India alone, and many more interpretations the world over, including in Indonesia, Malaysia, Japan, Trinidad and the curry capital of the UK, Bradford.

But curry is difficult to define. The word has origins in ancient India, but its adoption by Portuguese and British colonisers saw curry reinterpreted in the west to encompass an entire cuisine, prompting many Indians to reject the term outright.

Sejal Sukhadwala probes the complex intersection of tradition and colonialism through the fascinating history of curry, from its association with Ayurveda – one of the world's oldest holistic healing systems to its enduring popularity in contemporary British culture.

Garnishing this history is a surfeit of helpful advice on which oils to use, how to temper spices and where to find those all-important mouth-watering recipes.

Contributor Bio

Sejal Sukhadwala is a food writer who lives in London. She is frequently asked to write about Indian food and restaurants; over 20 years, she has written for a wide range of publications in the UK, US and India including the *Guardian*, *The Times* and *BBC Food*.

Quotes

"A magisterial must-read." - Nigella Lawson

"*The Philosophy of Curry* is Sejal Sukhadwala's marvellous, rollicking history of how one simply-named spiced dish finds its origin in extraordinary Indian cooking, while also representing the best and worst of British society's view of India, and its diaspora, through a complex cuisine and heritage." - Dan Lepard, chef and author

"In this gorgeously illustrated book, Sukhadwala dives head-long into the discussion of whether curry should be cancelled due to its association with colonialism and use as a limiting stereotype for the vast range of South Asian dishes. She delivers her response with terrific writing and panache." - Krishnendu Ray, Chair of the Department of Nutrition and Food Studies, New York University

Unpublished Endorsements

"A magisterial must-read." - Nigella Lawson

"Witty writing, trustworthy research, forceful opinions, and perfect illustrations. You won't find a better overview of curry and curry politics than this." - Rachel Laudan, author of *Cuisine and Empire: Cooking in World History*

THE PHILOSOPHY OF BEARDS

A lecture
physiological,
artistic and
historical



'The absence
of beard is
usually a sign
of physical
and moral
weakness.'

THOMAS S. GOWING



British Library
9780712357661
0712357661
Pub Date: 23/10/2014
\$10.00/\$16.95 Can./£10.00 UK
Hardcover

80 Pages
8 black & white illustrations
Carton Qty: 38
WH
Series: Philosophies
Sales Restrictions: NSA
Internation Pub Date: 2014-12-27
20 cm H | 13 cm W
Status: **ACTIVE**

The Philosophy of Beards

Thomas S. Gowing

Key Selling Points

Amusing, often bizarre gift book on a highly fashionable subject

Vintage title republished for the first time since 1850

Accompanied by illustrations of impressive beards from history

This eccentric Victorian book argues a strong case for the universal wearing of a beard - that essential symbol of manly distinction since ancient times.

Summary

'The absence of Beard is usually a sign of physical and moral weakness.' 'Take two drawings of the head of a lion, one with and the other without the mane. You will see how much of the majesty of the king of the woods, as well as that of the lord of the earth, dwells in this free-flowing appendage.' 'There is scarcely a more naturally disgusting object than a beardless old man. The Beard keeps gradually covering, varying and beautifying, and imparts new graces even to decay, by heightening all that is still pleasing, veiling all that is repulsive.' This eccentric Victorian book argues a strong case for the universal wearing of a beard - that essential symbol of manly distinction since ancient times. Thomas S. Gowing contrasts the vigour and daring of bearded men through history with the undeniable effeminacy of the clean-shaven. He reminds the modern man that 'ladies, by their very nature, like everything manly', and cannot fail to be charmed by a 'fine flow of curling comeliness'. Gowing's book is now republished for the first time since 1850, accompanied by illustrations of impressive beards from history.

Contributor Bio

Thomas S. Gowing is the author of *Normal Schools: And the Principles of Government Interference with Education*.

Quotes

"A delightfully entertaining manifesto that is short on philosophy, long on facial hair, and bound to appeal to high-brow and low-brow readers alike."
-PopMatters

Table Of Contents

Preface
Introduction
Physiology
Artistic Division
Historical Survey
Ecclesiastical History
Modern History

Illustrations

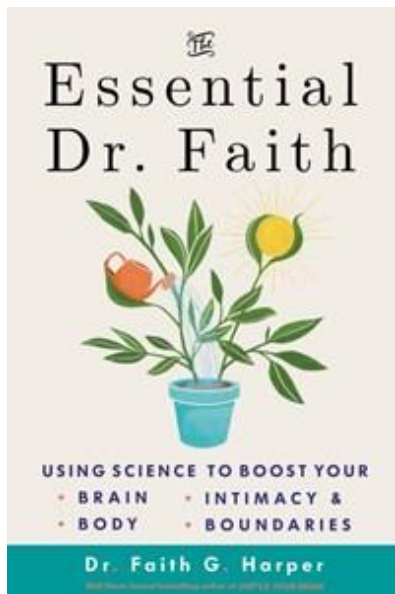

The Essential Dr. Faith

Using Science to Boost Your Brain, Body, Intimacy, and Boundaries

Dr. Faith G. Harper

Key Selling Points

- According to the American Psychological Association in 2023, 66% of Americans have a chronic illness and 37% have been diagnosed with a mental health condition
- Adults are increasingly turning to therapy, and when unable to access that (42% of adults with a diagnosed mental health condition couldn't afford therapy in 2021), to self-help books and social media for support with their mental and physical health, boundaries, and relationships
- Author's previous books have sold over 3 million copies

Summary

If you're like most of us, there's more than one aspect of your life that could use some unfucking.

More often than not, the challenges of mental health, physical health, boundaries, sex, and relationships are tied together in a big, overwhelming tangle. And when it comes to sorting ourselves out, it's hard to know where to begin.

But take heart: this comprehensive resource from bestselling author Dr. Faith G. Harper makes that process a whole lot easier. Combining the tools and insights from four of her most essential titles-*Unfuck Your Brain*, *Unfuck Your Body*, *Unfuck Your Boundaries*, and *Unfuck Your Intimacy*-this omnibus empowers you to tackle all parts of your life on your way to becoming your best self.

If you're new to Dr. Faith's work, *Unfuck Your Life* is the perfect introduction to her accesible, funny, science-based approach to getting your act together.

Contributor Bio

Dr. Faith G. Harper, LPC-S, ACS, ACN, is a badass, funny lady with a PhD. She's a licensed professional counselor, board supervisor, certified sexologist, and applied clinical nutritionist with a private practice and consulting business in San Antonio, TX. She has been an adjunct professor and a TEDx presenter and is proud to be a woman of color and an uppity intersectional feminist. She is the Wall Street Journal bestselling author of the book *Unfuck Your Brain* and many other popular zines and books on subjects such as anxiety, depression, boundaries, and grief. She is available as a public speaker and for corporate and clinical trainings. Subscribe to the *Unfuck Your Brain* newsletter to get a discount on her books and zines.

Marketing Plans

- National and Local Media Campaigns
- Pre-Publication Online Publicity Campaign
- Email Marketing and Publicity Campaign
- Curated Advanced Reader Copy Distribution
- Digital Influencer "Buzz" Campaign
- Social Media Promotions
- Kickstarter Campaign

Comp Titles

Unfuck Your Brain	Harper, Faith G.	Microcosm Publishing	11/7/2017	9781621063049	\$14.95	Trade Paperback	Self-Help
Unfuck Your Intimacy	Harper, Faith G.	Microcosm Publishing	6/11/2019	9781621067627	\$14.95	Trade Paperback	Family & Relationships

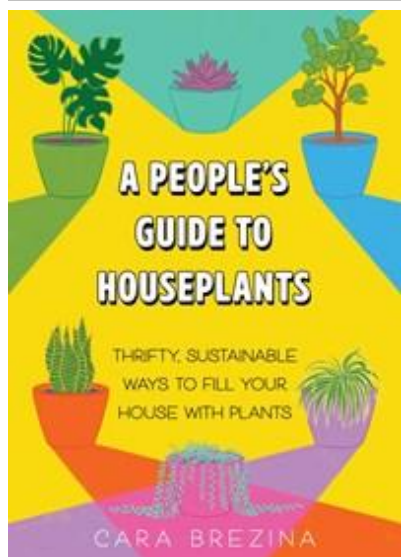

A People's Guide to Houseplants

Thrifty, Sustainable Ways to Fill Your Home with Plants

Cara Brezina

Key Selling Points

- 66% of US households own at least one houseplant
- Millennials are the fastest-growing demographic of plant parents, with their houseplant purchasing going up 65% in 2021; 1 in 3 people under 40 refer to themselves as a "plant parent"
- 2/3 of Gen Z and Millennials have a grim outlook about the economy, and these generations are most likely to report financial stress

Summary

Want to fill your home with lush greenery? You can do it without breaking the bank or your back. Cara Brezina shares her love of plants and offers advice on how to choose, nurture, and not kill the houseplants in your life—all without spending a bunch of money.

With the help of clear illustrations and straightforward instructions, learn to find free or affordable plants and herbs; propagate from cuttings, roots, and your dinner scraps; create dazzling displays, cactus gardens, and terrariums on a budget; find sustainable planting materials; and fertilize your plants without spending big.

Discover the joy of experimentation and seeing what you can make grow. No matter where you live, how broke you are, or how hectic your life is, you can turn your home into a green oasis and make lasting friends with your houseplants.

Contributor Bio

Cara Brezina is a freelance writer and editor who lives in Chicago, Illinois. She has authored educational nonfiction books on a wide range of topics, and also enjoys writing sci-fi, fantasy and mystery stories.

Marketing Plans

- National and Local Media Campaigns
- Pre-Publication Online Publicity Campaign
- Email Marketing and Publicity Campaign
- Curated Advanced Reader Copy Distribution
- Digital Influencer "Buzz" Campaign
- Social Media Promotions

Microcosm Publishing
9781648412875
1648412874
Pub Date: 11/12/2024
\$14.95/\$19.99 Can.
Trade Paperback

192 Pages
Carton Qty: 60
Gardening / House Plants &
Indoor
GAR010000

7 in H | 5 in W | 0.2 in T
Status: **FORTHCOMING**

Comp Titles

Mycocultural Revolution	McCoy, Peter	Microcosm Publishing	11/29/2022	9781621065142	\$17.95 USD	Hardcover Paper over boards	Nature
Homesweet Homegrown	Biggs, Jennifer	Microcosm Publishing	7/20/2012	9781934620106	\$9.95 USD	Trade Paperback	Gardening

No sales or inventory history loaded for this account. If you think there should be or would like to learn how to load this data, [Click here](#).

Subrights

No subrights have been specified.



Tea Magic

Cozy Spells in a Cup

Chloé Zarka Grinsnir

Key Selling Points

- **TAPS INTO A HOT TREND:** The idea of "romanticizing your life" is going strong, per *The New York Times*. The power of simple acts such as drinking a daily cup of tea are front and center. This has been reflected in the witchcraft community, in which cottagecore and cozy vibes continue to proliferate.
- **AMAZING AUTHOR:** Chloé Zarka Grinsnir has a passion for tea magick and has illustrated a number of graphics depicting tea spells that have garnered thousands of "likes" each on Instagram. Her love of this subject and its aesthetics is strong throughout this book.
- **GORGEOUS PACKAGE:** With full-color art throughout and a foil stamped cover, this book will make an excellent gift or just a lovely object to have on the shelf.

Summary

Brewing a cup of tea can lead to a variety of exciting magical practices, and Tea Magic is the perfect, gorgeously illustrated guide.

A steaming cup of tea can be the perfect source of comfort on a brisk fall day—and, as Chloé Zarka Grinsnir's fascinating book reveals, it is also a potent form of magic that can be effortlessly used to add magic to day-to-day life. Little things done with intent can have great power, and the ritual of tea drinking itself can bring strength during difficult times, energize ordinary tasks with positivity when a new opportunity arises, or provide a deep and necessary connection to intuition in situations that may seem unclear. *Tea Magic* is beautifully decorated with illustrations of gorgeous tea cups, colorful teas, and the kinds of magical details that have made Chloé's art so popular online. But more than that, it's a thoughtful resource that covers topics such as the energetic correspondences of different kinds of teas and herbs, as well as the properties of accoutrements such as fruits, sweeteners, and milks. Optimal conditions for drying tea leaves and herbs for magical teas are covered, as well as unique practices such as using moon water in teas—and, of course, tasseomancy, or reading tea leaves for divination. *Tea Magic* is an essential, easy-to-use resource for anyone who would like to add tea to their spellwork, and a perfect gift for all kinds of tea lovers, even those who don't yet have a magical practice.

Sterling Ethos
9781454955573
1454955570
Pub Date: 11/12/2024
On Sale Date: 11/12/2024
\$14.99/\$19.99 Can./£12.99 UK
Discount Code: T
Hardcover

144 Pages
all in color
Carton Qty: 44
Print Run: 25K
Body, Mind & Spirit / Witchcraft
OCC026000
Territory: World
6.5 in H | 5.5 in W
Status: **ACTIVE**

Related Products

Ebooks

9781454955580

Contributor Bio

Chloé Zarka Grinsnir is a freelance illustrator. She loves witchcraft and fashion, and she incorporates these things into her illustrations. She is obsessed with historical fashion, cottagecore, pretty dresses, and fall aesthetics. Chloé lives in Germany.

Illustrations



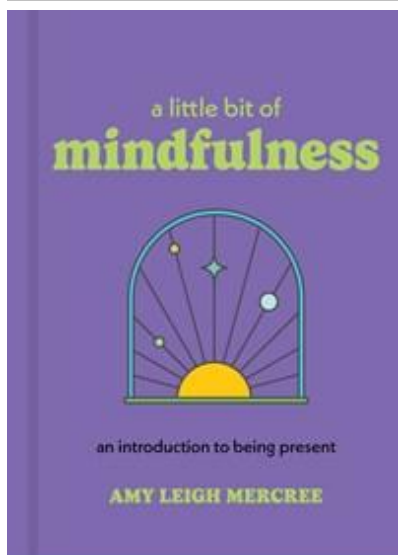

A Little Bit of Mindfulness

An Introduction to Being Present

Amy Leigh Mercree

Key Selling Points

- New entries in the successful series, which has sold over 100,000 copies
- Gifty books that break down complex spiritual subjects into bite-size pieces of actionable and accessible information
- Fun illustrations throughout
- Easy-to-understand and filled with helpful exercises

Summary

In the "Little Bit of" series: a fresh, accessible introduction to the increasingly popular spiritual practice of mindfulness: being present and peaceful in the moment.

In these fast-paced modern times, mindfulness can keep us centered, calm, and energized—no matter how much the outside world keeps distracting us. Thanks to Amy Leigh Mercree's accessible introduction, beginners can master this spiritual practice. You'll learn methods for cultivating inner peace, accessing a deeper creativity, and creating a healthier body, along with rituals that support these mindfulness techniques.

Contributor Bio

Amy Leigh Mercree is the bestselling author of six books including *The Compassion Revolution: 30 Days of Living from the Heart* (Llewellyn) and *A Little Bit of Meditation: An Introduction to Mindfulness* (Sterling). She also coauthored *A Little Bit of Chakras: An Introduction to Energy Healing* (Sterling).

Sterling Ethos
9781454958932
1454958936
Pub Date: 11/5/2024
On Sale Date: 11/5/2024
\$9.99/\$12.99 Can.
Discount Code: T
Hardcover

128 Pages
all in 2-color
Carton Qty: 36
Body, Mind & Spirit / Mindfulness
& Meditation
OCC010000
Series: Little Bit Series
Territory: World
7 in H | 5 in W
Status: **ACTIVE**

Comp Titles

The Mood Book	Mercree, Amy Leigh	Sterling Ethos	3/4/2019	9781454933182 1454933186	\$16.95 USD	Hardcover	Body, Mind & Spirit
A Little Bit of Goddess	Mercree, Amy Leigh	Sterling Ethos	10/22/2019	9781454936701 1454936703	\$9.95 USD	Hardcover	Body, Mind & Spirit
100 Days to Calm	Mercree, Amy Leigh	Sterling Ethos	5/5/2020	9781454940296 1454940298	\$14.95 USD	Hardcover	Self-Help
A Little Bit of Goddess	Mercree, Amy Leigh	Sterling Ethos	1/7/2025	9781454960713 145496071X	\$9.99 USD	Hardcover	Body, Mind & Spirit
A Little Bit of Dreams	Michaels, Stase	Sterling Ethos	1/20/2015	9781454913016 1454913010	\$9.99 USD	Hardcover	Body, Mind & Spirit
A Little Bit of Crystals	Eason, Cassandra	Sterling Ethos	1/20/2015	9781454913030 1454913037	\$9.99 USD	Hardcover	Body, Mind & Spirit
A Little Bit of Chakras	Mercree, Chad	Sterling Ethos	6/28/2016	9781454919681 145491968X	\$9.95 USD	Hardcover	Body, Mind & Spirit
The Angel Bible	Raven, Hazel	Union Square & Co.	9/28/2006	9781402741906 1402741901	\$19.99 USD	Trade Paperback	Body, Mind & Spirit

No sales or inventory history loaded for this account. If you think there should be or would like to learn how to load this data, [Click here](#).

Subrights

No subrights have been specified.

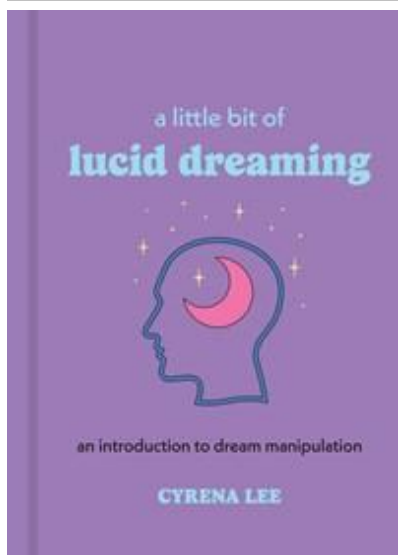

Sterling Ethos
9781454958925
1454958928
Pub Date: 11/5/2024
On Sale Date: 11/5/2024
\$9.99/\$12.99 Can./£8.99 UK
Discount Code: T
Hardcover

128 Pages
all in 2-color
Carton Qty: 36
Body, Mind & Spirit / Dreams
OCC006000
Series: Little Bit Series
Territory: World
7 in H | 5 in W
Status: **ACTIVE**

A Little Bit of Lucid Dreaming

An Introduction to Dream Manipulation

Cyrena Lee

Summary

An introduction to the practice of lucid dreaming—including instructions on how to do it yourself.

Lucid dreaming is, simply put, the realization that you are dreaming. It is to wake up *inside* a dream, and to know that everything you see before you is a product of your imagination and consciousness. It can be disorienting, but once you know that, you can actually take control of your dream. Cyrena Lee, a longtime expert on the topic, takes you through the history of lucid dreaming from ancient times to the present. She describes the therapeutic benefits of the practice, from its use in eliminating sleep issues and increasing your quality of sleep to its role in rewriting past traumas and promoting creativity. She coaches you through exercises to remember dreams, keep a dream journal, fall asleep while fully conscious, and practice dream meditation and dreaming yoga. She even includes some advanced techniques, such as moving objects in dreams and talking to dream characters who can help you achieve clarity in your waking life. This exciting and accessible look at a growing practice presents uncharted opportunities for personal and spiritual growth.

Contributor Bio

Cyrena Lee is a freelance writer based in New York City and Paris, France. She studied anthropology at Barnard College, and moved to Shanghai to explore the world of advertising at Ogilvy. Since then, she's worked in creative marketing, and is currently writing a novel and a collection of short stories. She is also the editor of *The Slow Scroll*, a weekly newsletter from IRL Labs. Find her online at cyrena-lee.com.

Comp Titles

A Little Bit of Dreams	Michaels, Stase	Sterling Ethos	1/20/2015	9781454913016 1454913010	\$9.99 USD	Hardcover	Body, Mind & Spirit
------------------------	-----------------	----------------	-----------	-----------------------------	---------------	-----------	---------------------

No sales or inventory history loaded for this account. If you think there should be or would like to learn how to load this data, [Click here](#).

Subrights

No subrights have been specified.

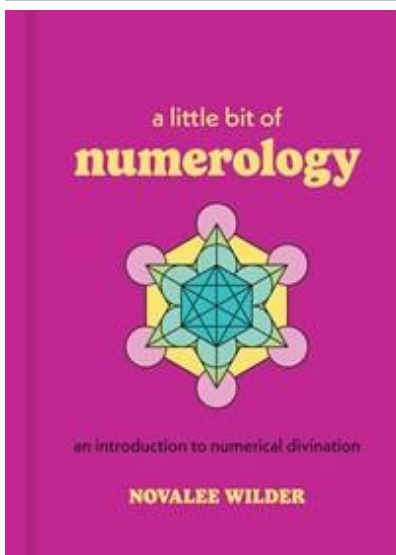

Sterling Ethos
9781454958949
1454958944
Pub Date: 11/5/2024
On Sale Date: 11/5/2024
\$9.99/\$12.99 Can./£8.99 UK
Discount Code: T
Hardcover

128 Pages
all in 2-color
Carton Qty: 36
Body, Mind & Spirit / Numerology
OCC015000
Series: Little Bit Series
Territory: World
7 in H | 5 in W
Status: **ACTIVE**

A Little Bit of Numerology

An Introduction to Numerical Divination

Novalee Wilder

Key Selling Points

- Series has sold half-a-million copies combined
- Cute and gifty package
- Contemporary and accessible (though highly authoritative!) voice
- Author will promote online and through New York City-based events

Summary

This entry in the popular Little Bit Of series introduces the age-old study of numerology.

Through the energetic power of numbers, it's possible to gain insights into the core of who we are and what specific gifts and challenges we are here to master. Practicing numerologist Novalee Wilder provides an overview of the ancient esoteric system of numerology, including its history and origins. A step-by-step guide shows how to calculate your essence by examining the numbers 1 through 9, and using the results to explore your personality, understand essential life lessons, and figure out goals. Wilder also discusses the concept of name vibrations, the Numeroscope (a numerologist's greatest tool), understanding others through numerology (using famous figures throughout history as examples), and applying this knowledge to your daily life.

Contributor Bio

Novalee Wilder is an actress and artist turned numerologist and writer. Originally from Copenhagen, she now works with individual and corporate clients from all over the world. She lives in Astoria, NY.

Comp Titles

A Little Bit of Angel Numbers	Wilder, Novalee	Sterling Ethos	12/19/2023	9781454952596 1454952598	\$9.99 USD	Hardcover	Body, Mind & Spirit
A Little Bit of Dreams	Michaels, Stase	Sterling Ethos	1/20/2015	9781454913016 1454913010	\$9.99 USD	Hardcover	Body, Mind & Spirit
A Little Bit of Crystals	Eason, Cassandra	Sterling Ethos	1/20/2015	9781454913030 1454913037	\$9.99 USD	Hardcover	Body, Mind & Spirit
A Little Bit of Chakras	Mercree, Chad	Sterling Ethos	6/28/2016	9781454919681 145491968X	\$9.95 USD	Hardcover	Body, Mind & Spirit

No sales or inventory history loaded for this account. If you think there should be or would like to learn how to load this data, [Click here](#).

Subrights

No subrights have been specified.

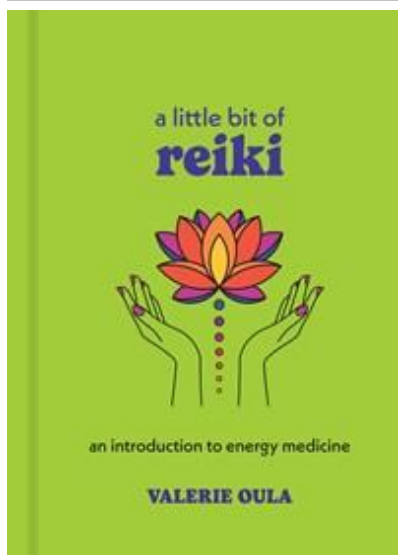

Sterling Ethos
9781454958956
1454958952
Pub Date: 11/5/2024
On Sale Date: 11/5/2024
\$9.99/\$12.99 Can./£8.99 UK
Discount Code: T
Hardcover

128 Pages
all in 2-color
Carton Qty: 36
Body, Mind & Spirit / Healing
OCC011010
Series: Little Bit Series
Territory: World
7 in H | 5 in W
Status: **ACTIVE**

A Little Bit of Reiki

An Introduction to Energy Medicine

Valerie Oula

Key Selling Points

- New entries in the successful series, which has sold more than 250,000 copies
- Gifty books that break down complex spiritual subjects into bite-size pieces of actionable and accessible information
- Fun illustrations throughout
- Easy-to-understand book filled with helpful exercises

Summary

In the popular "Little Bit of" series: a fresh, accessible introduction to the practice of Reiki.

The Japanese art of Reiki can reduce stress, aid relaxation, enhance energy, and promote healing. Expert teacher Valerie Oula introduces you to this profoundly beneficial hands-on practice, providing a history of Reiki and an overview of how it works. She includes exercises and meditations to help you tune into reiki energy and shows you where to go to experience a session and what to do to become a Reiki practitioner.

Contributor Bio

Valerie Oula is a kundalini yoga instructor and reiki master teacher. She is also trained in NLP, hypnosis, past-life regression, and other healing modalities. Valerie is the founder of Modern Ritual NYC, a line of deluxe artisanal energetic creations for mind, body, and soul. She lives in New York City.

Comp Titles

The Mood Book	Mercree, Amy Leigh	Sterling Ethos	3/4/2019	9781454933182 1454933186	\$16.95 USD	Hardcover	Body, Mind & Spirit
Rest Rituals	Oula, Valerie	Sterling Ethos	4/26/2022	9781454944690 1454944692	\$16.99 USD	Hardcover	Body, Mind & Spirit
A Little Bit of Dreams	Michaels, Stase	Sterling Ethos	1/20/2015	9781454913016 1454913010	\$9.99 USD	Hardcover	Body, Mind & Spirit
A Little Bit of Crystals	Eason, Cassandra	Sterling Ethos	1/20/2015	9781454913030 1454913037	\$9.99 USD	Hardcover	Body, Mind & Spirit
A Little Bit of Chakras	Mercree, Chad	Sterling Ethos	6/28/2016	9781454919681 145491968X	\$9.95 USD	Hardcover	Body, Mind & Spirit
The Angel Bible	Raven, Hazel	Union Square & Co.	9/28/2006	9781402741906 1402741901	\$19.99 USD	Trade Paperback	Body, Mind & Spirit

No sales or inventory history loaded for this account. If you think there should be or would like to learn how to load this data, [Click here](#).

Subrights

No subrights have been specified.

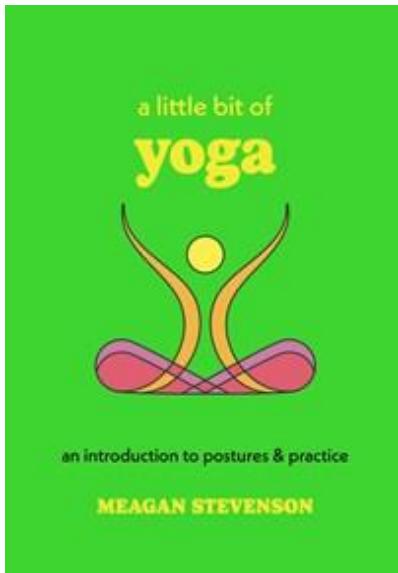

A Little Bit of Yoga

An Introduction to Postures & Practice

Meagan Stevenson

Key Selling Points

- New entries in the successful series, which has sold over 100,000 copies
- Gifty books that break down complex spiritual subjects into bite-size pieces of actionable and accessible information
- Fun illustrations throughout

Summary

In the popular "Little Bit of" series: a fresh, accessible introduction to the postures and practice of yoga.

Although it is an age-old practice originating in India, yoga is still embraced by many as a means of enhancing physical, mental, and spiritual health. Not only does it calm and strengthen, but yoga can improve flexibility and mental clarity through deep breathing and poses.

This accessible introduction presents the history and philosophy of the form, along with basic poses—including Adho Mukha Svanasana/"Downward Facing Dog," Virabhadrasana/"Warrior," and Vrksasana/"Tree"—and advice on incorporating them into a daily exercise program.

An introduction to postures and practice.

Contributor Bio

Meagan Stevenson is a hatha-vinyasa power-flow yogi who is 200-hour certified through ANYA. She's also certified in Aerial yoga (50 hours) and Schwinn cycling, and Lyra-certified with Cirqfit. She lives in Brooklyn, NY.

Illustrations



Sterling Ethos
 9781454959427
 1454959428
 Pub Date: 11/5/2024
 On Sale Date: 11/5/2024
 \$9.99/\$12.99 Can.
 Discount Code: T
 Hardcover

128 Pages
 all in 2-color
 Carton Qty: 36
 Health & Fitness / Yoga
 HEA025000
 Series: Little Bit Series
 Territory: World
 7 in H | 5 in W
 Status: **ACTIVE**



— ADVANCED BOOK INFORMATION —

— November 2024 | Paperback | 440pp | £18.99 | 9781911723431 | 216x138mm | Middle East Studies —

NEW, UPDATED PAPERBACK EDITION

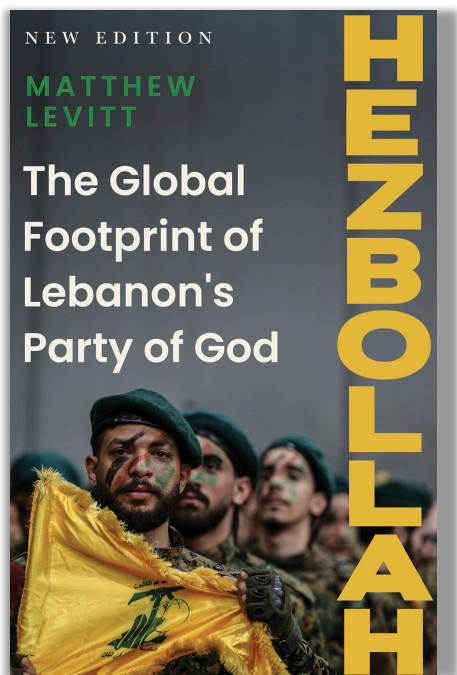

Hezbollah

The Global Footprint of Lebanon's Party of God

Matthew Levitt

- Investigates the financial and logistical support networks of Hezbollah and its criminal and terrorist operations worldwide.
- A comprehensive look at Hezbollah from its foundations to its work abroad, including in Europe and the USA
- Author international Hezbollah who has been quoted in the House of Commons Parliamentary debate on Hezbollah's international connections

'Hezbollah reads more like a thriller than an academic work. Having said that, it is meticulously researched [and] replete with fascinating tidbits of information significantly adding to the reader's growing impression of Hezbollah's global reach.' — *The Times of Israel*

'[Matthew Levitt] narrates the full history of [Hezbollah] in absorbing detail with an emphasis on its thirty-year history of terrorism. While scholarly in tone and approach, Mr. Levitt's book delivers suspenseful and even terrifying blow-by-blow accounts of the most infamous of Hezbollah's attacks.' — *Wall Street Journal*

'Matthew Levitt is a recognised authority on Hezbollah and its activities, both in the Levant and globally. ... *Hezbollah: The Global Footprint of Lebanon's Party of God* fills a vital gap in understanding the international dimensions of Hezbollah, its reach, and its capacities for terrorism worldwide.' — Charles Allen, former Assistant Director of Central Intelligence for Collection, CIA

'Matthew Levitt has made a significant contribution to public understanding of Hezbollah's worldwide operations. He has shone a bright light into some of the darkest corners of the group's activities overseas.' — Richard Barrett, former head of MI6/SIS/British Intelligence's Counter Terrorism Department and coordinator of the United Nations Al-Qaeda-Taliban Monitoring Team

Hezbollah — Lebanon's 'Party of God' — is a multifaceted organisation: it is a powerful political party in Lebanon, a Shia religious and social movement, Lebanon's largest militia, a close ally of Iran, and a terrorist organisation. Drawing on a wide range of sources, including recently declassified government documents, court records, and personal interviews with intelligence officials, Matthew Levitt examines Hezbollah's beginnings, its first violent forays in Lebanon, and then its terrorist activities and criminal enterprises abroad in Europe, the Middle East, South America, Southeast Asia, Africa, and finally in North America. He also discusses Hezbollah's unit dedicated to supporting Palestinian militant groups and the group's involvement in training and supporting insurgents who fought US troops in post-Saddam Iraq. The book concludes with a look at Hezbollah's integral and ongoing role in Iran's 'shadow war' with Israel and the West, including plots targeting civilians around the world. Levitt shows convincingly that Hezbollah's willingness to deploy violence at home and abroad, its global reach, and its proxy-patron relationship with the Iranian regime are all matters worthy of the utmost concern.

— ADVANCED BOOK INFORMATION —

— November 2024 | HB | 480pp, 150 colour illus | £25 | 9781805260974 | 234 x156mm | History / Architecture —

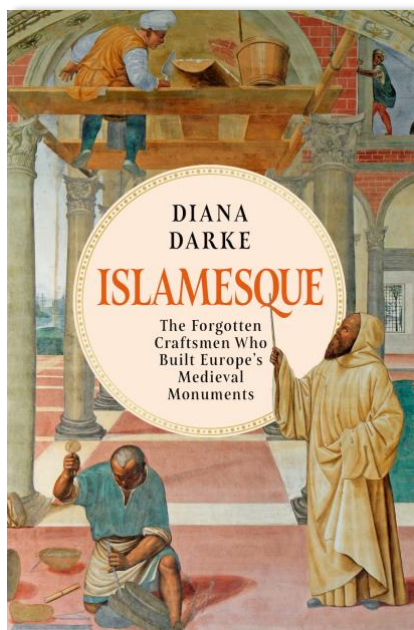

Islamesque

The Forgotten Craftsmen Who Built Europe's Medieval Monuments

Diana Darke

- A fascinating exploration of Europe's medieval architectural wonders—and the Muslim master-builders behind them.
- Highlights dramatic discoveries that challenge existing, Euro-centric assumptions about Europe's built heritage.
- Author of acclaimed book *Stealing from the Saracens*.

Who really built Europe's finest Romanesque monuments? Abbots and bishops presiding over holy sites receive mentions aplenty throughout history, while their highly skilled creators remain anonymous. But the buildings speak for themselves. In this groundbreaking book, Middle East cultural historian Diana Darke explores the evidence embedded in medieval monasteries, churches and castles across Europe, from Mont Saint-Michel and the Leaning Tower of Pisa to Durham Cathedral and the Basilica of Santiago de Compostela. Tracing the origins of key decorative and architectural innovations during this pre-Gothic period—acknowledged as the essential foundation of all future European construction styles—she sheds new light on the mystery masons, carpenters and sculptors behind these masterpieces. Her discoveries are dramatic. At a time when Christendom lacked such expertise, Muslim craftsmen, with their advanced understanding of geometry and complex ornamentation styles, dominated the high-end construction industry in Islamic Spain, Sicily and North Africa, spreading their knowledge and techniques across Western Europe. Challenging Euro-centric assumptions about the continent's built heritage, Darke uncovers the profound influence of the Islamic world in 'Christian' Europe, and argues that 'Romanesque' architecture, a fiction first invented by nineteenth-century French art historians, should be recognised as what it truly is: Islamesque.



Diana Darke has spent four decades in the Middle East. Her books include *Islamesque* and *Stealing from the Saracens* (both published by Hurst), *My House in Damascus* and *The Ottomans*. A non-resident scholar at Washington DC's Middle East Institute, she holds degrees in Arabic and in Islamic Art and Architecture.

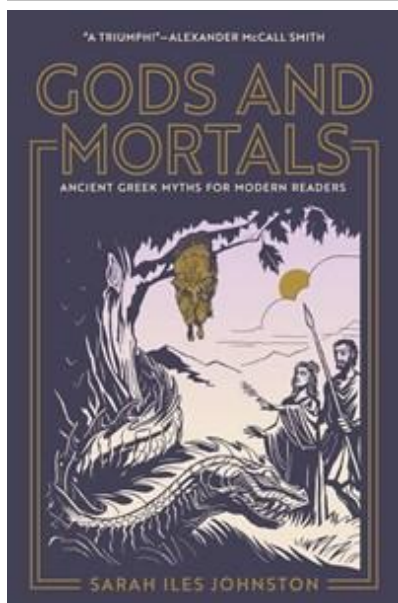

Princeton University Press
9780691239873
0691239878
Pub Date: 9/17/2024
On Sale Date: 9/17/2024
\$24.95/\$32.00 Can./£20.00
UK/€24.99 EU
Discount Code: TP
Trade Paperback

496 Pages
16 b/w illus. 1 table.
Literary Collections / Ancient &
Classical
LCO003000
8 in H | 5.3 in W
Status: **ACTIVE**

Gods and Mortals

Ancient Greek Myths for Modern Readers

Sarah Iles Johnston

An entrancing new telling of ancient Greek myths

"This book is a triumph! . . . [A] magnificent retelling of the Greek myths."—Alexander McCall Smith, author of the No. 1 Ladies' Detective Agency series

"Move over, Edith Hamilton! Sarah Iles Johnston has hit the magical refresh button on Greek myths."—Maria Tatar, author of *The Heroine with 1001 Faces*

Summary

An entrancing new telling of ancient Greek myths

"This book is a triumph! . . . [A] magnificent retelling of the Greek myths."—Alexander McCall Smith, author of the No. 1 Ladies' Detective Agency series

"Move over, Edith Hamilton! Sarah Iles Johnston has hit the magical refresh button on Greek myths."—Maria Tatar, author of *The Heroine with 1001 Faces*

Gripping tales that abound with fantastic characters and astonishing twists and turns, Greek myths confront what it means to be mortal in a world of powerful forces beyond human control. Little wonder that they continue to fascinate readers thousands of years after they were first told. *Gods and Mortals* is a major new telling of ancient Greek myths by one of the world's preeminent experts. In a fresh, vibrant, and compelling style that draws readers into the lives of the characters, Sarah Iles Johnston offers new narrations of all the best-known tales as well as others that are seldom told, taking readers on an enthralling journey from the origin of the cosmos to the aftermath of the Trojan War.

Some of the mortals in these stories are cursed by the gods, while luckier ones are blessed with resourcefulness and resilience. Gods transform themselves into animals, humans, and shimmering gold to visit the earth in disguise—where they sometimes transform offending mortals into new forms, too: a wolf, a spider, a craggy rock. Other mortals—both women and men—use their wits and strength to conquer the monsters created by the gods—gorgons, dragons, harpies, fire-breathing bulls.

Featuring captivating original illustrations by Tristan Johnston, *Gods and Mortals* highlights the rich connections between the different characters and stories, draws attention to the often-overlooked perspectives of female characters, and stays true both to the tales and to the world in which ancient people lived. The result is an engaging and entertaining new take on the Greek myths.

Contributor Bio

Sarah Iles Johnston is the College of Arts and Sciences Distinguished Professor of Religion and Professor of Classics at The Ohio State University, where she teaches courses on Greek myths. Her many books include *The Story of Myth*, *Ancient Greek Divination*, and *Restless Dead: Encounters between the Living and the Dead in Ancient Greece*. **Tristan Johnston** is an illustrator and graphic designer whose work includes books for children and adults, as well as storyboards and graphics for apparel. He lives in Los Angeles with his wife and two sons.

Quotes

"[A] superb retelling. . . . Nuanced, sympathetic and deeply moving."—Michael Dirda, *Washington Post*

"Sarah Iles Johnston brings exceptional verve and scholarship to *Gods and Mortals: Ancient Greek Myths for Modern Readers*, a comprehensive volume. . . . [Johnston]

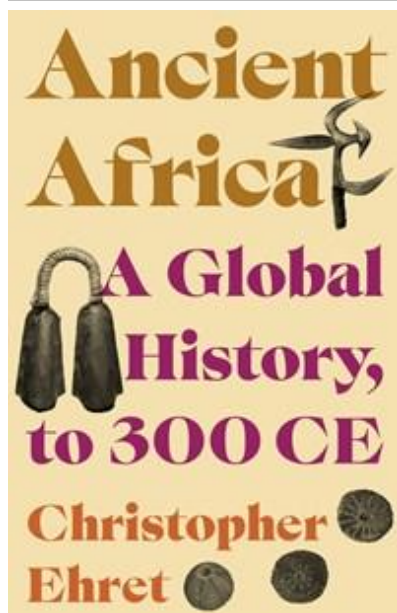

Princeton University Press
 9780691244860
 0691244863
 Pub Date: 11/5/2024
 On Sale Date: 11/5/2024
 \$19.95/\$24.99 Can./£14.99
 UK/€19.99 EU
 Discount Code: TP
 Trade Paperback

224 Pages
 20 b/w illus. 2 tables. 16 maps.
 History / Africa
 HIS001000

8 in H | 5.3 in W
 Status: **ACTIVE**

Ancient Africa

A Global History, to 300 CE

Christopher Ehret

Summary

A panoramic narrative that places ancient Africa on the stage of world history

This book brings together archaeological and linguistic evidence to provide a sweeping global history of ancient Africa, tracing how the continent played an important role in the technological, agricultural, and economic transitions of world civilization. Christopher Ehret takes readers from the close of the last Ice Age some ten thousand years ago, when a changing climate allowed for the transition from hunting and gathering to the cultivation of crops and raising of livestock, to the rise of kingdoms and empires in the first centuries of the common era.

Ehret takes up the problem of how we discuss Africa in the context of global history, combining results of multiple disciplines. He sheds light on the rich history of technological innovation by African societies—from advances in ceramics to cotton weaving and iron smelting—highlighting the important contributions of women as inventors and innovators. He shows how Africa helped to usher in an age of agricultural exchange, exporting essential crops as well as new agricultural methods into other regions, and how African traders and merchants led a commercial revolution spanning diverse regions and cultures. Ehret lays out the deeply African foundations of ancient Egyptian culture, beliefs, and institutions and discusses early Christianity in Africa.

A monumental achievement by one of today's eminent scholars, *Ancient Africa* offers vital new perspectives on our shared past, explaining why we need to reshape our historical frameworks for understanding the ancient world as a whole.

Contributor Bio

Christopher Ehret is Distinguished Research Professor in the History Department at the University of California, Los Angeles. His many books include *The Civilizations of Africa: A History to 1800* and *History and the Testimony of Language*.

Quotes

"A Seminary Co-Op Notable Book of the Year"

"A Choice Outstanding Academic Title of the Year"

"Finalist for the PROSE Award in Biological Anthropology, Ancient History, and Archaeology, Association of American Publishers"

"A vital reconsideration of world history." -Publishers Weekly

"Ehret provides a vital new perspective on Africa's significant role in the ancient world. This is an essential book on early African history that uses several types of evidence to demonstrate how different groups in Africa impacted each other and eventually the world." -Library Journal

"Ehret charts the many pathways of interconnection between Africa and the world. . . . At a time when people seem more divided than ever, it's refreshing and rather moving to read a book which humanely reminds us of how much we all have in common."---**Toby Green, Daily Telegraph**

"Although the ancestors of all human beings alive today lived in Africa, the continent and the history of its peoples occupy remarkably little space in histories of the ancient world. *Ancient Africa* goes a long way toward rectifying that. . . . This masterful, accessible summary of a brilliant historian's life's work will appeal to everyone interested in ancient world history." -Choice Reviews

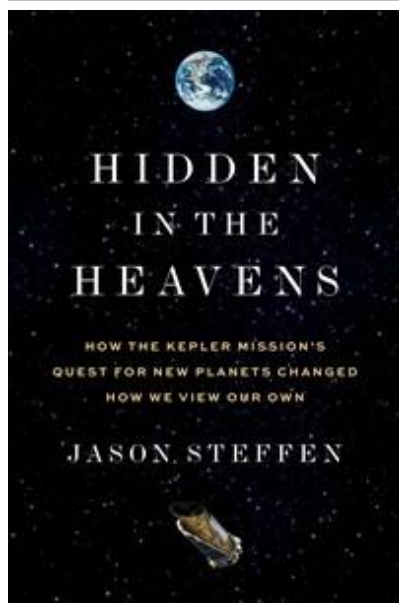

Princeton University Press
9780691242477
069124247X
Pub Date: 10/29/2024
On Sale Date: 10/29/2024
\$29.95/\$38.00 Can./£25.00
UK/€29.99 EU
Discount Code: TC
Hardcover

272 Pages
8 page color insert + 4 b/w illus.
Science / Space Science
SCI004000

9.3 in H | 6.1 in W
Status: **ACTIVE**

Hidden in the Heavens

How the Kepler Mission's Quest for New Planets Changed How We View Our Own

Jason Steffen

Summary

An insider's account of the NASA mission that changed our understanding of planets, planetary systems, and the stars they orbit

Are we alone in the universe? It's a fundamental question for Earth-dwelling humankind. Are there other worlds like ours, out there somewhere? In *Hidden in the Heavens*, Jason Steffen, a former scientist on NASA's Kepler mission, describes how that mission searched for planets orbiting Sun-like stars—especially Earth-like planets circulating in Earth-like orbits. What the Kepler space telescope found, Steffen reports, contradicted centuries of theoretical and observational work and transformed our understanding of planets, planetary systems, and the stars they orbit. Kepler discovered thousands of planets orbiting distant stars—a bewildering variety of celestial bodies, including rocky planets being vaporized by the intense heat of their host star; super-Earths and sub-Neptunes, with properties simultaneously similar to and different from both Earth and Neptune; gas giants several times the size and mass of Jupiter; and planets orbiting in stellar systems that had only been imagined in science fiction.

It was, Steffen says, the opportunity of a lifetime to work in the most exciting scientific field on the most awe-inspiring mission. He offers a unique, inside account of the work of the Kepler science team (and the sometimes chaotic interactions among team members), mapping the progress of the mission from the launch of the rocket that carried Kepler into space to the revelations of the data that began to flow to the supercomputer back at NASA—evidence of strange new worlds unlike anything found in our own solar system.

Contributor Bio

Jason Steffen is associate professor of physics at the University of Nevada, Las Vegas. A longtime science team member of NASA's Kepler mission, he has contributed to the discovery and characterization of thousands of planets that orbit distant stars.

Quotes

"An eye-opening exploration of the goals, successes, and challenges associated with the [Kepler space telescope mission]. . . . This will please armchair astronomers."
-Publishers Weekly

"An excellent piece of science writing. . . . For a scientist to write a narrative that is good storytelling is quite remarkable. Steffen accomplished this feat."---**David Bullock, *The Space Page***

"Jason Steffen gives readers an exceptionally granular view of the entire [Kepler Space Telescope] mission, managing to pack an incredible amount of information into a relatively slim volume"---**Douglas G. Adler, *Ad Astra***

Unpublished Endorsements

"*Hidden in the Heavens* records the fascinating journey of a young researcher exploring the myriad of planets orbiting other stars. Jason Steffen provides both a history of the Kepler Mission and a thorough discussion of what we have learned from it—as well as an account of the many surprises he encountered along the way. A delightful read."
—**William Borucki, Kepler PI**

"This is a compelling book about three launches: the launch of a spacecraft, the launch of a scientific career, and the launch of a new phase of astronomical discovery."

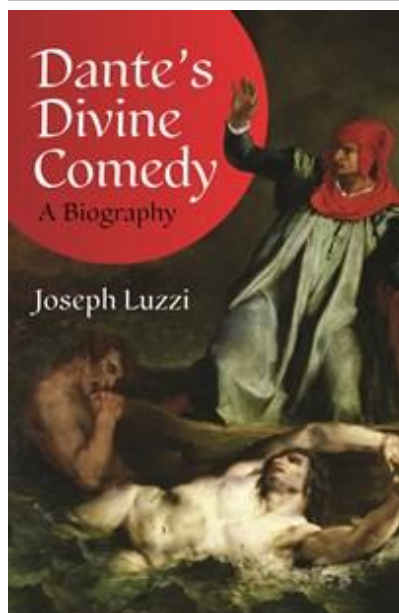

Princeton University Press
 9780691156774
 0691156778
 Pub Date: 11/5/2024
 On Sale Date: 11/5/2024
 \$24.95/\$32.00 Can./£20.00
 UK/€24.99 EU
 Discount Code: TC
 Hardcover

232 Pages
 16 b/w illus.
 Literary Criticism / European
 LIT004200

8.5 in H | 5.5 in W
 Status: **ACTIVE**

Dante's Divine Comedy

A Biography

Joseph Luzzi

Summary

The life and times of Dante's soaring poetic allegory of the soul's redemptive journey toward God

Written during his exile from Florence in the early 1300s, Dante Alighieri's *Divine Comedy* describes the poet's travels through hell, purgatory, and paradise, exploring the state of the human soul after death. His *poema sacro*, sacred poem, profoundly influenced Renaissance writers and artists such as Giovanni Boccaccio and Sandro Botticelli and was venerated by modern critics including Erich Auerbach and Harold Bloom. *Dante's "Divine Comedy"* narrates the remarkable reception of Dante's masterpiece, one of the most consequential religious books ever written.

Tracing the many afterlives of Dante's epic poem, Joseph Luzzi shows how it left its mark on the work of such legendary authors as John Milton, Mary Shelley, and James Joyce while serving as a source of inspiration for writers like Primo Levi and Antonio Gramsci as they faced the most extreme forms of political oppression. He charts how the dialogue between religious and secular ideas in *The Divine Comedy* has shaped issues ranging from changing conceptions of women's identity and debates about censorship to the role of canonical literature in popular culture.

An intimate portrait of a work that has challenged and inspired generations of readers, *Dante's "Divine Comedy"* reveals how Dante's strikingly original and controversial vision of the afterlife can help us define our spiritual beliefs, better understand ourselves, and navigate the complexities of modern life.

Contributor Bio

Joseph Luzzi is the Asher B. Edelman Professor of Literature at Bard College. His books include *Botticelli's Secret: The Lost Drawings and the Rediscovery of the Renaissance*; *In a Dark Wood: What Dante Taught Me About Grief, Healing, and the Mysteries of Love*; and *My Two Italies*.

Quotes

"Erudite. . . . Luzzi covers the seven centuries since the [*Divine*] *Comedy's* publication with concision and verve. It's a fleet-footed overview of the influential poem's eventful afterlife." -Publishers Weekly

"A learned but accessibly written essay on a centerpiece of the European literary tradition and its continuing influence." -Kirkus Reviews

Unpublished Endorsements

"Celebrating Dante's profound influence on a pantheon of other cultural icons—from Boccaccio and Botticelli to Mary Shelley, Gramsci, Fellini, and Pope Francis—Luzzi shows why the *Divine Comedy* matters as the greatest poem, at once spiritual and secular, in the Western tradition."—**Guy P. Raffa, author of *Dante's Bones: How a Poet Invented Italy***

Marketing Plans

ADVERTISING PLAN:

- Times Literary Supplement Ad
- PMLA Ad
- London Review of Books Ad
- Facebook/Instagram ad

Eric Storm



A World History



Princeton University Press
9780691233093
0691233098
Pub Date: 10/29/2024
On Sale Date: 10/29/2024
\$39.95/\$50.00 Can./£35.00
UK/€40.00 EU
Discount Code: S
Hardcover

512 Pages
34 b/w illus. 7 maps.
Political Science / Political
Ideologies
POL031000

9.3 in H | 6.1 in W
Status: **ACTIVE**

Nationalism

A World History

Eric Storm

Summary

A global perspective on the nature and evolution of nationalism, from the early modern era to the present

The current rise of nationalism across the globe is a reminder that we are not, after all, living in a borderless world of virtual connectivity. In *Nationalism*, historian Eric Storm sheds light on contemporary nationalist movements by exploring the global evolution of nationalism, beginning with the rise of the nation-state in the eighteenth century through the revival of nationalist ideas in the present day. Storm traces the emergence of the unitary nation-state—which brought citizenship rights to some while excluding a multitude of “others”—and the pervasive spread of nationalist ideas through politics and culture.

Storm shows how nationalism influences the arts and humanities, mapping its dissemination through newspapers, television, and social media. Sports and tourism, too, have helped fashion a world of discrete nations, each with its own character, heroes, and highlights. Nationalism saturates the physical environment, not only in the form of national museums and patriotic statues but also in efforts to preserve cultural heritage, create national parks, invent ethnic dishes and beverages, promote traditional building practices, and cultivate native plants. Nationalism has even been used for selling cars, furniture, and fashion.

By tracing these tendencies across countries, Storm shows that nationalism’s watershed moments were global. He argues that the rise of new nation-states was largely determined by shifts in the international context, that the relationships between nation-states and their citizens largely developed according to global patterns, and that worldwide intellectual trends influenced the nationalization of both culture and environment. Over the centuries, nationalism has transformed both geopolitics and the everyday life of ordinary people.

Contributor Bio

Eric Storm is associate professor of general history at Leiden University. He has been a visiting scholar at the University Complutense of Madrid, Oxford University, and the Free University in Berlin. He is the author of *The Culture of Regionalism* and *The Discovery of El Greco* and the coeditor of *Writing the History of Nationalism, Colonial Soldiers in Europe, Regionalism in Modern Europe, and World Fairs and the Global Moulding of National Identities*.

Quotes

"Comprehensive. . . . A detailed examination of the origin, use, and future of nationalist ideologies." -Kirkus Reviews

Unpublished Endorsements

"A historical tour de force, this highly readable book disentangles the manifold ways in which nationalist ideas and movements have shaped modern politics around the world."
—**Andreas Wimmer, author of *Nation Building: Why Some Countries Come Together While Others Fall Apart***

"Building on the most exciting recent scholarship, *Nationalism: A World History* very effectively captures the patterns and dynamics that allow us to understand nationalism as the inherently global phenomenon that it was."—**Sebastian Conrad, author of *What is Global History?***

"INVITING AND READABLE." —NEW YORK TIMES

ECONOMICS IN AMERICA

AN IMMIGRANT ECONOMIST
EXPLORES THE LAND OF INEQUALITY

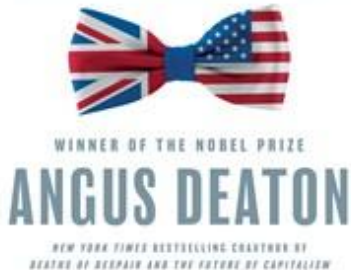

Princeton University Press
9780691247847
0691247846
Pub Date: 10/22/2024
On Sale Date: 10/22/2024
\$17.95/\$22.99 Can./£14.99
UK/€17.99 EU
Discount Code: TP
Trade Paperback

296 Pages
Business & Economics / Economic
History
BUS023000

8 in H | 5.3 in W
Status: **ACTIVE**

Economics in America

An Immigrant Economist Explores the Land of Inequality

Angus Deaton

Summary

From the Nobel Prize–winning economist and *New York Times* bestselling coauthor of *Deaths of Despair and the Future of Capitalism*, candid reflections on the economist's craft

When economist Angus Deaton immigrated to the United States from Britain in the early 1980s, he was awed by America's strengths and shocked by the extraordinary gaps he witnessed between people. *Economics in America* explains in clear terms how the field of economics addresses the most pressing issues of our time—from poverty, retirement, and the minimum wage to the ravages of the nation's uniquely disastrous health care system—and narrates Deaton's account of his experiences as a naturalized US citizen and academic economist.

Deaton is witty and pulls no punches. In this incisive, candid, and funny book, he describes the everyday lives of working economists, recounting the triumphs as well as the disasters, and tells the inside story of the Nobel Prize in economics and the journey that led him to Stockholm to receive one. He discusses the ongoing tensions between economics and politics—and the extent to which economics has any content beyond the political prejudices of economists—and reflects on whether economists bear at least some responsibility for the growing despair and rising populism in America.

Blending rare personal insights with illuminating perspectives on the social challenges that confront us today, Deaton offers a disarmingly frank critique of his own profession while shining a light on his adopted country's policy accomplishments and failures.

Contributor Bio

Angus Deaton, winner of the 2015 Nobel Prize in economics, is the Dwight D. Eisenhower Professor of Economics and International Affairs Emeritus and Senior Scholar at Princeton University. He is the author (with Anne Case) of the *New York Times* bestselling book *Deaths of Despair and the Future of Capitalism* (Princeton).

Quotes

"A Financial Times Best Book of the Year: Economics"

"A Times Literary Supplement Book of the Year"

"[An] excellent new book . . . exploring everything from inequality to deaths of despair to the failures of the field in which he won the Nobel prize. It's all leavened with sardonic humor."---**Nicholas Kristof**

"Deaton recounts his journey to understanding the political and economic dysfunctions of his adopted home. It's sort of like Alexis De Tocqueville's classic *Democracy in America*, but with more numbers, more economics, and more vitriol. . . . Rare for an economist, Deaton offers a lucid and unsparing critique of America's political system."---**Greg Rosalsky, NPR's Planet Money**

"Inviting and readable."---**Jennifer Szalai, New York Times**

"Highly enjoyable. . . . Deaton emerges from the book as a decent human being who wants to make the world a better place."---**Martin Wolf, Financial Times**

"Deaton's prose is lucid and tartly down-to-earth (the U.S. government works 'to help rich predators make ordinary people poorer,' he writes), and he makes a convincing case that 'economics should be about understanding the reasons for and doing away with the sordidness and joylessness that come with poverty and deprivation.' The

— ADVANCED BOOK INFORMATION —

— Nov 2024 | PB | 448pp, 19 b&w illus | £14.99 | 9781911723868 | 198 x129mm | History / WWII / Cold War —

NEW PAPERBACK EDITION

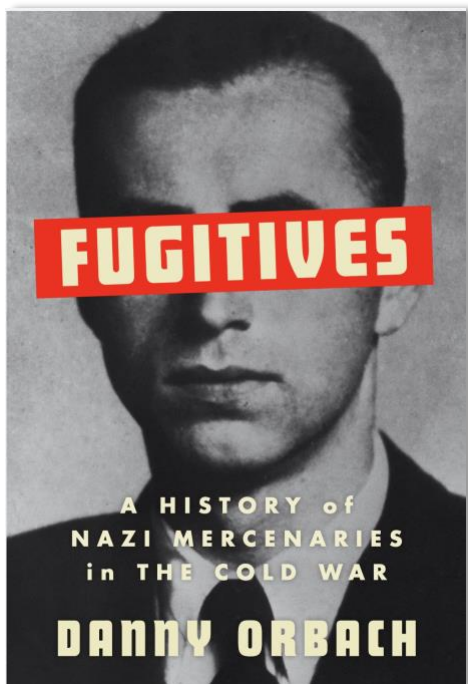

Fugitives

A History of Nazi Mercenaries

During the Cold War

Danny Orbach

- From Spain to Syria, the thrilling, untold history of Nazi fugitives turned postwar agents—for America, the Soviets, the Third World, or themselves.
- While other books have investigated Nazis post-WII, this is the first to focus on their role as agents in the Middle East and Third World in addition to the USA and Soviet Union.
- The author's first book on Nazism, *The Plots Against Hitler*, has been translated into seven different languages.

‘Riveting ... a horrifying and entertaining account of the role played by former (or so they claimed) Nazis in Cold War espionage.’ — *The Daily Telegraph*

‘A gripping and often shocking account of what the former Nazis did next ... consistently absorbing and judiciously written.’ — *The Times*

‘Genuinely revelatory ... impressive and scholarly ... the many fascinating narratives ... could easily provide the raw material for a dozen espionage novels ... a lot of writers will be inspired.’ — *The New Statesman*

Reinhard Gehlen, founder of West German foreign intelligence, welcomed SS operatives into the fold, overestimating their supposed capabilities. This shortsighted decision nearly brought down his cherished service, as the KGB found his Nazi operatives easy to turn or expose. However, Gehlen was hardly alone in this cynical strategy; the American, Soviet, French and Israeli secret services—and nationalist organisations and independence movements—all used former Nazi operatives in the early Cold War. Nazi fugitives became freelance arms traffickers, spies, and assassins, playing crucial roles in the clandestine contest between the superpowers. From posh German restaurants, smuggler-infested Yugoslav ports, and fascist holdouts in Franco’s Spain to Damascene safehouses and Egyptian country clubs, these spies created a busy network of influence and information, a uniquely combustible ingredient in the covert struggles of the postwar decades. Unearthing newly declassified revelations from Mossad and other archives, historian Danny Orbach reveals this long-forgotten arena of the Cold War, and its colourful cast of characters. Shrouded in official secrecy, clouded by myth and propaganda, the extraordinary tale of these Nazi agents has never been properly told—until now.

Danny Orbach is an associate professor in the History and Asian Studies Departments at the Hebrew University of Jerusalem. He received his PhD from Harvard University. His prior books include *Curse on This Country: The Rebellious Army of Imperial Japan*, and *The Plots Against Hitler*, which has been published in seven languages. Danny lives in Jerusalem.

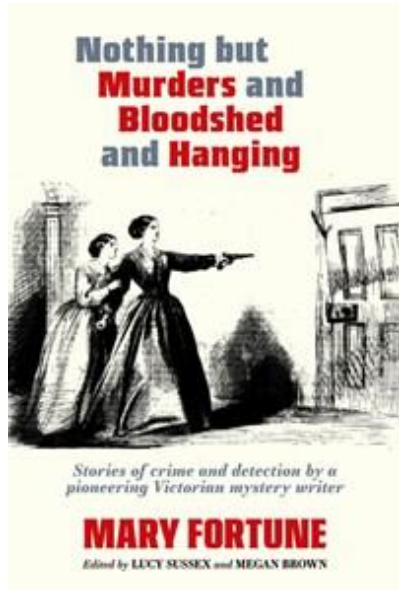

Verse Chorus Press
9781959163091
1959163094
Pub Date: 4/03/2025
On Sale Date: 4/03/2025
Ship Date: 31/01/2025
\$19.95/\$25.99 Can./£17.99
UK/€17.99 EU
Trade Paperback

310 Pages
15 Illustration(s)
Carton Qty: 20
Fiction / Mystery & Detective
FIC022060

22.9 cm H | 15.2 cm W
Status: **FORTHCOMING**

Related Products

Also Available
9781760645052
Ebooks
9781959163107

Nothing But Murders and Bloodshed and Hanging

Stories of crime and detection by a pioneering Victorian mystery writer

Mary Fortune, Lucy Sussex, Megan Brown

Summary

A murderer is identified by a team of oxen. A dead man rises from a watery grave to indict his killer. A phantom hearse gliding through Melbourne's slums foretells violent death. A seamstress turns detective to avenge her friend's homicide. A locked-tent mystery.

Such are the themes of Mary Fortune's ingenious and dramatic crime stories. Between 1865 and 1910 she wrote over 500 of them; they comprise the first ever detective fiction series written by a woman. Set in the outback, on the goldfields, and in the burgeoning metropolis of Melbourne, they offer a vivid account of life and death in colonial-era Australia. Fortune tackled subjects such as murder, armed robbery, bootlegging, and sexual violence with a frankness unprecedented for a woman in the 19th century, in styles ranging from melodrama and Gothic horror to social realism and what is now called noir. This book brings together 17 of her finest stories, edited and introduced by literary historians Lucy Sussex and Megan Brown.

Born in Ireland in 1832, Fortune arrived in Australia during the gold-rush, which she observed firsthand and depicted in many of her stories. A brief, bigamous marriage to a policeman gave her inside knowledge to write about crime, and over the next 40 years her prolific output was serialized under the title *The Detective's Album* in the mass-circulation *Australian Journal*. She often lived precariously—struggling with alcohol, unable to prevent her son drifting into a life of crime—and preserved her privacy by publishing under pseudonyms. Her anonymity meant that when she died in 1911 she was almost lost to literary history. Only recently have Mary Fortune's true identity and her extraordinary life story emerged.

This collection, together with a simultaneously published biography, will confirm Mary Fortune's status as a trailblazing crime writer.

"The themes of marriage, murder, and gendered violence resonate with contemporary concerns. The writing is beautiful, complex, and thrilling . . . From the small towns of the goldfields to the arid yet lush landscape of the outback, and back to society living in Melbourne, these stories will enthrall you."—Candice Fox

Contributor Bio

Mary Fortune (1833-1911) was a founding mother of crime and mystery fiction, the author of hundreds of detective stories as well as hard-hitting journalism. Born in Belfast, she married in Canada and emigrated to Australia in 1855 with her young son and an assignment to write about the goldrushes. There she gave birth to a second, illegitimate son, George Fortune, who became a career criminal. In 1858 she made a bigamous marriage to a policeman, from whom (together with her own experience of the goldfields and bohemian Melbourne life) she acquired source material for the police procedurals that make up her *Detective's Album*, serialized for forty years in the bestselling monthly *The Australian Journal*. Fortune published under the pseudonyms "Waif Wander" and "W. W.", thus shielding her identity and earning a precarious living even when she was jailed for drunkenness, or had no fixed address. Her true identity was almost lost forever, but dedicated research has revealed an extraordinary woman and her story.

LUCY SUSSEX is a novelist and literary historian. She has written six novels, including *The Scarlet Rider*, a fictionalized account of her search for Mary Fortune, and over thirty short stories, many of which are collected in *Matilda Told Such Dreadful Lies: The*

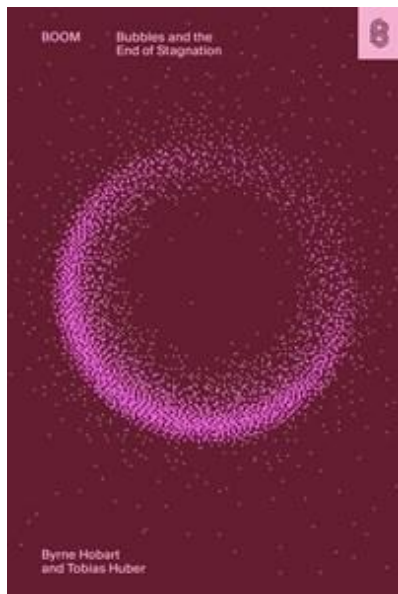

Boom

Bubbles and the End of Stagnation

Byrne Hobart, Tobias Huber

Key Selling Points

- **Built-in audience:** Byrne Hobart will promote the book to over 50,000 paying subscribers to his newsletter, The Diff, as well as over 46,000 followers on Twitter.
- **Innovative thesis:** *Boom* makes the provocative, compelling, and counterintuitive claim that bubbles aren't all bad—in fact, they may create the ideal conditions for transformative innovation.
- **Well-connected authors:** The authors have a pedigree in Silicon Valley and in academia. Their network includes investor Peter Thiel, economist Tyler Cowen, and entrepreneur Marc Andreessen. All three have agreed to blurb the book.
- **For fans of Zero to One:** The book draws heavily on concepts from Peter Thiel's bestselling book *Zero to One* and will attract the same readership.
- **Engaged community:** Stripe Press has a sizable community of avid fans, who run the gamut from startup founders to executives at some of the world's largest companies.

Summary

A timely investigation of the causes of technological and scientific stagnation, and a radical blueprint for accelerating innovation.

"Read this book for the alternative history of our age."

—**Peter Thiel, investor and author of *Zero to One***

"A must-read for those who seek to build the future."

—**Marc Andreessen, cofounder of Netscape and Andreessen Horowitz**

From the Moon landing to the dawning of the atomic age, the decades prior to the 1970s were characterized by the routine invention of transformative technologies at breakneck speed. By comparison, ours is an age of stagnation. Median wage growth has slowed, inequality and income concentration are on the rise, and scientific research has become increasingly expensive and incremental.

Why are we unable to replicate the rate of progress of past decades? What can we do to reinvigorate innovation?

In *Boom*, Byrne Hobart and Tobias Huber take an inductive approach to the problem. In a series of case studies tracking some of the most significant breakthroughs of the past 100 years—from the Manhattan Project and the Apollo program to fracking and Bitcoin—they reverse-engineer how transformative progress arises from small groups with a unified vision, vast funding, and surprisingly poor accountability. They conclude that financial bubbles, while often maligned as destructive and destabilizing forces, have in fact been the engine of past breakthroughs and will drive future advances. In other words: Bubbles aren't all bad.

Integrating insights from economics, philosophy, and history, *Boom* identifies the root causes of the Great Stagnation and provides a blueprint for accelerating innovation. By decreasing collective risk aversion, overfunding experimental processes, and organizing high-agency individuals around a transcendent mission, bubbles are the key to realizing a future that is radically different from the present. *Boom* offers a definite and optimistic vision of our future—and a path to unleash a new era of global prosperity.

Contributor Bio

Byrne Hobart is an investor, consultant, and writer. He is the author of The Diff, a daily newsletter covering inflection points in finance and technology. He is also a

Stripe Press
9781953953476
1953953476
Pub Date: 11/19/2024
On Sale Date: 11/19/2024
\$35.00/\$45.99 Can./£24.99
UK/€30.99 EU
Discount Code: HC
Hardcover

304 Pages
Carton Qty: 14
Business & Economics
/ Economics
BUS069030

9 in H | 6 in W
Status: **ACTIVE**

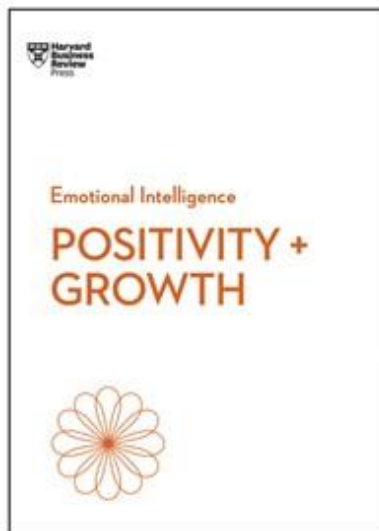

Harvard Business Review Press
9781647829933
1647829933
Pub Date: 12/10/2024
On Sale Date: 12/10/2024
\$19.99/\$25.99 Can./£10.99
UK/€17.99 EU
Discount Code: TP
Trade Paperback

176 Pages
Carton Qty: 48
Print Run: 30K
Business & Economics
/ Leadership
BUS071000
Series: HBR Emotional Intelligence Series
7 in H | 5 in W
Status: **FORTHCOMING**

Related Products

Other

Positivity and Growth (HBR Emotional Intelligence Series)
9781647829957 \$40.00

Also Available

Energy + Motivation (HBR Emotional Intelligence Series)
9781647824365 \$19.99
Focus (HBR Emotional Intelligence Series)
9781633696587 \$19.99
Resilience (HBR Emotional Intelligence Series)
9781633693234 \$19.99
Mindfulness (HBR Emotional Intelligence Series)
9781633693197 \$19.99

Ebooks

9781647829940

Positivity and Growth (HBR Emotional Intelligence Series)

Harvard Business Review

Key Selling Points

A carefully curated collection of articles about the connection between positivity and personal and professional growth from *Harvard Business Review*.

- Highly curated collection of HBR articles.
- Includes a variety of perspectives from recognized experts on the topic.
- Teaches readers the importance of positivity (from both an outlook and mindset perspective) as it relates to personal and professional growth and development and how to cultivate it.
- Explains how positivity and growth tie into key emotional intelligence themes, such as empathy, self-awareness, social awareness, relationship management, and compassion.
- Helps readers understand the basics of a positive mindset as they learn to develop and/or strengthen theirs.
- Helps readers consider how their attitudes and emotions influence their own personal growth and development and also explore more about how positivity has an impact on the people, situations, and world around them and apply that to their work.
- Reviews the science behind positivity and personal and professional growth.
- Provides practical how-to's for managing common situations.

Audience: Professionals who are looking to better understand the importance of positivity as it relates to personal growth and development so that they can cultivate it in their work and lives.

Summary

Embrace the power of positivity.

Research shows a strong link between positive emotions and high performance. When you cultivate a positive mindset, you open yourself to a world of possibilities—to learning, to change, to hearing other perspectives.

This book explores how positivity fuels personal and professional growth. When you cultivate a positive outlook, you'll learn to embrace your strengths, see opportunities instead of problems, and make difficult choices. And positivity is contagious. When leaders are positive, everyone around them benefits, from finding greater job satisfaction to experiencing increased engagement and performance boosts. Cultivating a positive outlook lifts you up, along with everyone around you, creating an environment where everyone can grow and learn and flourish.

How to be human at work. The **HBR Emotional Intelligence Series** features smart, essential reading on the human side of professional life from the pages of *Harvard Business Review*. Each book in the series offers proven research showing how our emotions impact our work lives, practical advice for managing difficult people and situations, and inspiring essays on what it means to tend to our emotional well-being at work. Uplifting and practical, these books describe the social skills that are critical for ambitious professionals to master.

Contributor Bio

Harvard Business Review is the leading destination for smart management thinking. Through its flagship magazine, 12 international licensed editions, books from Harvard Business Review Press, and digital content and tools published on HBR.org, *Harvard Business Review* provides professionals around the world with rigorous insights and best practices to lead themselves and their organizations more effectively and to make a positive impact.

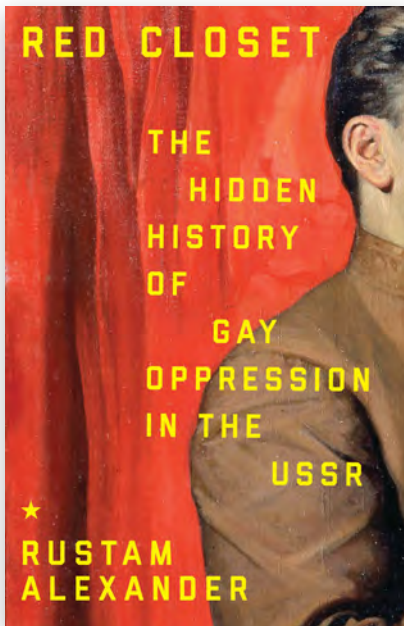

- Paperback £12.99
- February 2025
- 9781526181459
- 288pages: 216x138mm
- Social & cultural history

AUTHOR

Rustam Alexander is a historian and independent scholar who obtained his PhD from the University of Melbourne. He is the author of *Regulating homosexuality in Soviet Russia, 1956–91*.

Red closet

The hidden history of gay oppression in the USSR

Rustam Alexander

ENDORSEMENTS

'A crucially important and highly readable account of the oppression of gay men and lesbians in the Soviet Union.'

Siobhán Hearne, *CEU Review of Books*

KEY SALES POINTS

- A timely book that examines LGBTQI+ life across Russia and Ukraine under Soviet control.
- Based on unique historical evidence, it offers new information about doctors, actors, KGB officers and singers who tried to fight the system.
- Centred around individuals, each chapter explores what it was like to live under Soviet rule for gay and gay-friendly people.
- Instantly draws readers into its unique and compelling narratives.

DESCRIPTION

In 1934, Joseph Stalin enacted sodomy laws, unleashing a wave of brutal detentions of homosexual men in large Soviet cities.

Red closet recounts the compelling stories of people whose lives were affected by those laws, including a naïve Scottish journalist who dared to write to Stalin in an attempt to save his lover from prosecution and a homosexual theatre student who came to Moscow in pursuit of a career amid Stalin's harsh repressions and mass arrests. We also meet a fearless doctor in Siberia who provided medical treatment for gay men at his own peril and a much-loved Soviet singer who hid his homosexuality from the secret police.

Each story helps paint the hitherto unknown picture of how Soviet oppression of gay people originated and was perpetuated from Stalin's rule until the demise of the USSR. This book comes at a time when homophobia is again rearing its ugly head under Putin's rule.

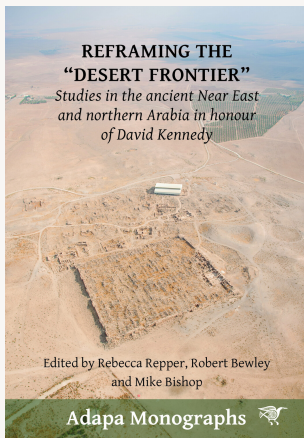

Reframing the “Desert Frontier”: Studies in the ancient Near East and northern Arabia in honour of David Kennedy

Edited by Rebecca Repper, Robert Bewley and Mike Bishop

SERIES

Adapa Monographs

PAPERBACK

978-1-74332-995-5

516 pages

254 × 178 mm

1 March 2025

A\$100

EPUB

978-1-74332-997-9

1 March 2025

A\$24.99

MARKET

Professional and scholarly

SUBJECT

SOC003000: SOCIAL SCIENCE / Archaeology

HDDC: Middle & Near Eastern archaeology

HDW: Archaeological science, methodology & techniques

NKD: Archaeology by period / region

NHG: Middle Eastern history

NKX: Archaeological science, methodology and techniques

- Synthesis of new and exciting research on the Roman Empire’s eastern frontier.
- Lavishly illustrated.
- In honour of a pioneering archaeologist in the Middle East
- New methodological approaches for 21st century archaeological practice.
- Reveals new sources for future research.

The eastern frontier of the Roman Empire – its network of roads, trade routes, towns and forts – is often conceived of as an “edge” of both empire and civilisation – but this “borderland” is also part of a rich cultural landscape. Our awareness and appreciation of these cultures has increased dramatically over the course of the last century. Scholarship has deepened, methods have advanced, and perspectives have shifted.

Reframing the “Desert Frontier” offers new insights into the rich cultural history of this region through the re-examination of existing material – such as archives, historical accounts, and previous surveys – and through the use of novel archaeological approaches across its 20 chapters. The bringing together of different methodological approaches to the archaeology of the region in a single volume highlights synergies and offers important comparisons for archaeologists to consider.

This volume highlights the work of Emeritus Professor David Kennedy, whose contribution to the study of the Roman army, the archaeology of Jordan, and aerial archaeology has inspired and enhanced multiple projects that have reframed this so-called “desert frontier”.

Reframing the “Desert Frontier” encapsulates the enriched view of this ancient region generated by new techniques of survey and analysis, changed perspectives on older materials, a more intense engagement with the rural landscapes surrounding ancient towns, and the addition of new discoveries that alter previous consensus.



SYDNEY UNIVERSITY PRESS

sydney.edu.au/sup



Tuttle Publishing
9784805319079
A\$24.99
Trade Paperback

152 Pages
manga illustrations throughout
Carton Qty: 40
Family & Relationships / Life Stages

210mm H | 147mm W
Status: **FORTHCOMING**

How to Connect, Share & Play Safely Online

A Manga Guide for Preteens, Teens and Parents

Narumi Sasaki, Popoko

Key Selling Points

- The ideal book for parents to share with their children about using smartphones in a positive way
- A detailed manga-style guide for young people explaining how to stay safe and avoid bullying, identity theft, sexual exploitation and other risks when using social media and the internet
- Engaging comics and sidebars that are easy for preteens and teens to absorb, with a cool Japanese manga aesthetic throughout
- Features infographics, resource guides, explanations of key terms like "digital tattoo" and "grooming," real-life examples, and handy guidelines for staying safe and not harming others
- Written by a former police detective with extensive experience investigating digital crimes and teaching kids positive online habits

Summary

An important book on how to stay safe online—presented in a fun manga style!

When young people get their first phone, they enter an online world of endless potential but also many real-life risks. This book clearly explains how to become a smart, safe digital citizen. Through an engaging mix of comics and sidebars, preteens and teens learn to navigate threats like bullying, identity theft, sexual grooming, fake news and screen addiction—so they don't become victims of crimes that can have devastating consequences in the real world.

Written by a former police detective with extensive experience investigating digital crimes, this book features infographics, explanations of key terms, real-life examples and simple guidelines for staying safe online.

Young readers will learn:

- How to spot fake information and avoid online scams
- What a "digital tattoo" is, and how to avoid getting one
- The sneaky tricks scammers use to get your data
- What photos and information should never be shared
- And much more!

Comics by Japanese illustrator Popoko have a cool manga aesthetic that appeals to young readers. This is the ideal book for parents who want to start a continuing conversation with their children about how to thrive in today's social media world.

Contributor Bio

Narumi Sasaki educates students about how to stay safe online and reduce crime. As the former Director of Digital Investigations for the Saitama Police Department in Japan, he gathered and analyzed digital evidence from computers, security cameras and smartphones, gaining experience in cybercrime investigation. He is currently director of School Police, an organization whose mission is to reduce students' risk of becoming involved in crime. In this role he raises awareness by speaking about crimes involving students, bullying, social media, the spread of inappropriate videos, and other high-stakes topics.

Popoko is an illustrator, nurse and single mother to a young son. She is the illustrator of *Manga Guide to Moods for Young People* and *Sex Isn't a Taboo: What Every Young Person Should Know About Sex, Birth Control, Gender, and Sexual Violence* (both from Shufu to Seikatsu Sha), among other books.



Pink-pilled

Women and the far right

Lois Shearing

KEY SALES POINTS

- Makes a unique contribution to understanding the place of women in far-right politics.
- Reveals the mechanisms by which women are radicalised online.
- Offers an accessible exploration of far-right politics and movements.
- Offers solutions for countering women's radicalisation

- Paperback £12.99
- February 2025
- 9781526170699
- 240 pages: 198x129mm
- Politics & gender studies

AUTHOR

Lois Shearing is a journalist and writer. They are the author of *Bi the Way: The Bisexual Guide to Life* (2021) and write about sex and relationships for *Cosmopolitan*.

DESCRIPTION

A daring investigation that explores how women are targeted and recruited by the far right.

As the far right has gained popularity and acceptance around the world, its ranks have swelled with an unlikely category of members: women.

Women play significant roles in far-right movements, acting as propagandists, prizes to be won and mother-warriors of the nation. But up to now their activities have been largely overlooked. In *Pink-pilled*, Lois Shearing provides a cutting-edge account of how the far right has used the internet to recruit women, while shedding light on what life is like for women within these movements, including their experiences of misogyny and violence.

Understanding how and why women join movements that explicitly aim to restrict their autonomy is essential if we want to fight back. *Pink-pilled* offers key insights for countering women's radicalisation and building communities resistant to far-right thought.

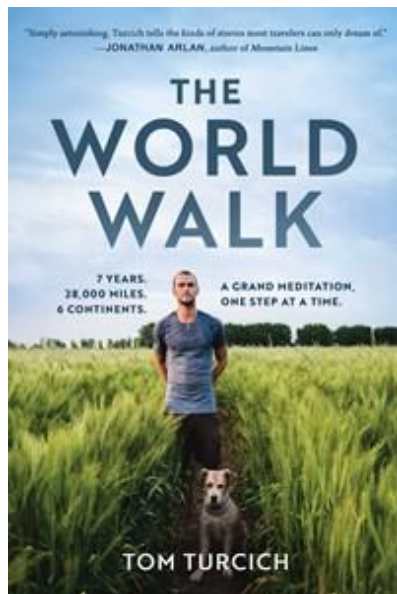

Skyhorse
9781510779013
Pub Date: 8/10/2024
\$28.99/\$38.99 Can./£22.00 UK
Hardcover

296 Pages
32 Full-Color Photos
Carton Qty: 24
Biography & Autobiography
/ Adventurers & Explorers
BIO023000

22.9 cm H | 15.2 cm W | 3.3 cm T
| 499 g Wt
Status: **ACTIVE**

The World Walk

7 Years. 28,000 Miles. 6 Continents. A Grand Meditation, One Step at a Time.

Tom Turcich

Summary

The invigorating true story of a man and his dog who circled the globe on foot.

"Quietly stunning." —Laurie Woolever, *New York Times* bestselling author of *World Travel with Anthony Bourdain* and *Bourdain: The Definitive Oral Biography*

After the death of a close friend at seventeen, Tom Turcich resolved to make the most out of life; to travel and be forced into adventure; to experience and understand the world. On April 2nd, 2015, he set out to see it all—one step at a time.

The World Walk is the emotional and exhilarating story of the tenth person and first dog to walk around the world. Together, Turcich and his dog, Savannah, covered twenty-eight thousand miles over the course of seven years. Through deserts, jungles, cities, and mountains, Turcich meditated on what's important in life and took lessons from cultures around the globe.

Rarely has there been a true-life tale of such scope. From sheltered suburbanite to world traveler, Turcich's epic account runs the full gamut: He is held up at knifepoint in Panama and gunpoint in Turkey; wanders deep within himself in the deserts of Peru; watches a democracy fortify itself in Georgia; and takes it all in with his resolute companion by his side. His growth spans the most basic elements of surviving on the road—finding food, water, and safe places to camp—to humanity's more noble aspirations, such as the benefits of democracy, the search for love, and the weighing of personal significance.

Accompanied by some of the author's world-class photography, this tour de force of resilience and triumph of the human spirit will reaffirm to readers that the world is beautiful, people are good, and life should be a generous, vibrant adventure.

Contributor Bio

Tom Turcich is the tenth person to walk around the world, completing an extraordinary seven-year journey across six continents and thirty-eight countries with his adopted pup, Savannah. What began as a quest for self-discovery, evolved into a testament to human endurance and the unbreakable bond between man and dog. Turcich has been featured on *CNN*, *Good Morning America*, *The Guardian*, *BBC*, *The Today Show*, and more. Now a sought-after motivational speaker, Turcich inspires audiences with tales of perseverance, adventure, and the transformative power of pursuing one's dreams. He is also the author of the children's book *Savannah's World of Adventure*.



Rocky Nook
 9798888142219
 9798888142219
 Pub Date: 10/1/2024
 On Sale Date: 10/1/2024
 \$14.95/\$19.95 Can./£13.99 UK
 Discount Code: TP

60 Pages
 Carton Qty: 112
 Art / Techniques
 ART029000

3.5 in H | 5.1 in W
 Status: **FORTHCOMING**

Related Products

Ebooks

9798888142240
 9798888142233
 9798888142226

Watercolor 101: Pocket Guide

Volta Voloshin-Smith

Key Selling Points

Rocky Nook's Pocket Guides are handy, ultra-portable, and quick to reference to help you quickly get information when on the go.

These pocket guides are designed for artists who haven't mastered every painting technique yet.

The author is a watercolor expert and previously published author who teaches popular workshops on painting.

Summary

Quickly learn the basics of brushwork, color mixing, and how to create gorgeous watercolor images while on the go!

Designed for artists who are starting out on their watercolor journey or those who just need a quick refresher on the basics, this handy and ultra-portable reference guide helps you create beautiful artwork whether in your studio or out and about

- Choose the right material including brushes, paper, palettes, and additional tools
- Learn basic watercolor techniques like wet-on-wet or wet-on-dry, layer, glazing, and textured effects
- Quickly reference the best way to color mix with a color wheel
- Master brushstroke techniques including for fine lines and details
- Apply simple perspective and composition rules
- Troubleshoot mistakes and learn how to avoid muddy colors and other common issues

Noted watercolor instructor Volta Volshin-Smith demystifies watercolor painting and distills her years of knowledge into this handy guide for all aspiring or expert artists.

Contributor Bio

Volta Voloshin-Smith is originally from Moldova and currently calls Dallas, TX her home. She founded Color Snack as a way to share tips, encourage others to live a creative life, and help build the next generation of artists by donating a portion of proceeds to local art education. Volta's mission to watercolor the world can be seen in her various projects such as brand activations, custom illustrations and animations that she creates for national and international brands. She also hosts virtual and in-person watercolor workshops where she encourages everyone to rediscover their inner artist. Visit her on Instagram @colorsnack

Marketing Plans

Generate Press release and distribute to identified, aligned publications and members of the media

Promote product through Rocky Nook site and social media channels

Establish affiliate programs to sell/market new title

Identify and target key influencers and extend outreach

Links

- [\(Author's Instagram, 8,321 followers\)](#)
- [Author's website](#)



Rocky Nook
9798888142776
9798888142776
Pub Date: 10/22/2024
On Sale Date: 10/22/2024
\$14.95/\$19.95 Can.
Discount Code: TP

52 Pages
Carton Qty: 80
Art / Techniques
ART034000

5.1 in H | 3.5 in W
Status: **FORTHCOMING**

Related Products

Ebooks

9798888142783
9798888142790
9798888142806

Drawing 101: Pocket Guide

Materials, Shading, Perspective, Shapes, Sketching, and More

Josh Powell

Key Selling Points

Rocky Nook's Pocket Guides are handy, ultra-portable, and easy to reference to help quickly get information on the go.

For artists who haven't mastered every technique yet or just need a quick refresher on the most vital information.

The author is a drawing instructor who specializes in teaching beginners.

Summary

Quickly learn the basics of sketching, form, perspective, and how to create stunning drawings while on the go.

Designed for artists who are starting out on their drawing journey or those who just need a quick refresher on the basics, this handy and ultra-portable reference guide helps you create beautiful artwork whether in your studio or out and about.

- Choose the right material including pencils, paper, pens, and additional tools
- Learn basic drawing skills like shading, depicting shapes, cross hatching, and quick sketching
- Apply simple perspective and composition rules
- Practice your skills with a series of to strengthen your observation and drawing abilities

Noted art instructor Josh Powell demystifies drawing and distills his years of knowledge into this handy guide for all aspiring or expert artists.

Contributor Bio

Josh Powell is an arts educator in San Rafael, California. He has a degree in Fine Art with an emphasis in drawing and painting from Cal State University San Francisco. He was also classically trained at L'Accademia di Belle Arti, Florence, Italy. Josh received his credential in art education from Dominican University of California and has been teaching in Marin County for the last 14 years.

Marketing Plans

Generate Press release and distribute to identified, aligned publications and members of the media

Promote product through Rocky Nook site and social media channels

Establish affiliate programs to sell/market new title

Identify and target key influencers and extend outreach

Links

- [Author's Website](#)
- [Author's Instagram](#)

Table Of Contents

01: Drawing Material

02: Importance of Grip

03: Seeing Like an Artist

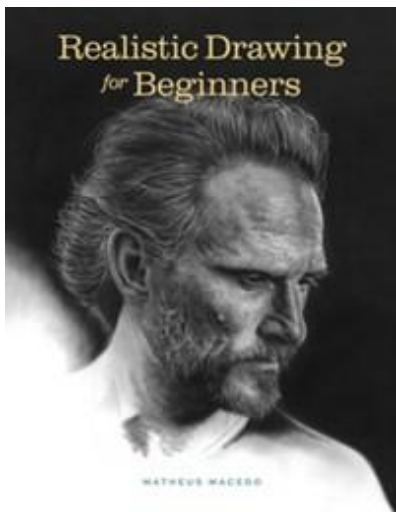

Rocky Nook
 9798888142134
 9798888142134
 Pub Date: 11/19/2024
 On Sale Date: 11/19/2024
 \$26.95/\$35.95 Can.
 Discount Code: TP
 Trade Paperback

144 Pages
 Carton Qty: 30
 Art / Techniques
 ART034000

7 in H | 9 in W
 Status: **FORTHCOMING**

Related Products

Ebooks

9798888142141
 9798888142158
 9798888142165

Realistic Drawing for Beginners

How to Create Stunning, Lifelike Drawings of Any Subject

Matheus Macedo

Key Selling Points

The author teaches a series of popular online drawing courses and has a strong social media following. He recently launched a new course on My Modern Met.

His photorealistic drawings of celebrities get thousands of likes and shares.

Author is in Brazil but is keen to a lot of online promotion.

Summary

The ultimate guide to drawing detailed, lifelike images. Creating an image that looks exactly like a real person or photograph may seem intimidating, or only for very advanced artists, but in this book noted art instructor Matheus Macedo demystifies the process and shows step-by-step how to create realistic drawings using reference photos as guidance. Readers will learn all aspects of realistic drawing, including:

- How to perceive the different values of light and shadow
- How to render precise details using different textures
- Choosing the right materials and how to use them
- Observing subjects and how to capture all aspects of the face, body, and different hair types

Filled with beautiful and instructive drawings of every step of the drawing process, this book builds upon the author's popular drawing courses and will teach anyone how to amaze their friends and family with their lifelike drawings.

Contributor Bio

Matheus Macedo is an artist and art instructor born in Brasilia, Brazil. He started drawing as a child and never stopped. While earning a degree in Architecture and Urbanism from his hometown university and an exchange period at the Politecnico di Torino in Italy, his interest in drawing remained. He took a series of in-person and online courses and workshops with world-class artists, falling in love with realism after experimenting with different materials and styles. He began giving private drawing lessons and would soon promote his work on social media. As interest in his work grew, he was repeatedly asked about his drawing process until he decided to share his secrets by recording online courses, reaching thousands of students from all over the world. Macedo was one of the winners of the international American Art Awards in 2022 and today he dedicates his time to sharing his technique for creating works in black and white and color.

Marketing Plans

Generate Press and add to Rocky Nook website

Distribute PR to identified, aligned publications and members of the media

Promote product through Rocky Nook site and social media channels

Establish affiliate programs to sell/market new title

Set-up author interviews/workshops with Bret Eviston

Work with author to generate relatable content to share alongside the release of book (how-to, blog post, photo contest, social promotions)

Links

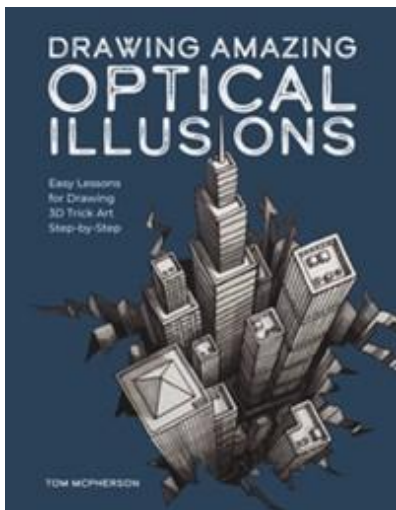

Rocky Nook
 9798888141564
 9798888141564
 Pub Date: 11/19/2024
 On Sale Date: 11/19/2024
 \$24.95/\$33.95 Can./£19.49 UK
 Discount Code: TP
 Trade Paperback

192 Pages
 Carton Qty: 24
 Art / Techniques
 ART010000

9 in H | 7 in W
 Status: **FORTHCOMING**

Related Products

Ebooks

9798888141595
 9798888141588
 9798888141571

Drawing Amazing Optical Illusions

Easy Lessons for Drawing 3D Trick Art Step-by-Step

Tom McPherson

Key Selling Points

Author has a strong social media following with thousands of followers across YouTube, Facebook, and Instagram.

The author's most popular videos are about drawing 3D optical illusions.

Very few books on the market about the topic but the ones out there sell well, even self-published comps.

Summary

Create mind-blowing artwork that pops off the page!

Drawing complex three-dimensional art does not have to be intimidating. It may seem difficult or only for the advanced artist, but in this book author Tom McPherson breaks down in simple step-by-step instructions how anyone can create detailed, mesmerizing optical illusions even with little drawing experience.

McPherson details how to create cool artwork from scratch by learning basic drawing techniques and progressing to more complex skills and creations, including:

Impossible Shapes: Optical 3D illusions of shapes that could not exist in reality

Floating Shapes: Solid shapes that look like they hover above the paper

3D Line Art: Inventive 3D illusions on simple lined paper

Anamorphic Buildings: Subjects drawn with extreme distortion that look realistic and 3D

And much more! This is the ultimate guide to mastering trick drawing and creating cool images that will impress your friends and family.

Contributor Bio

Tom McPherson is an artist and Founder of Circle Line Art School which he created to help encourage as many people as possible to improve their drawing skills. He has taught thousands of students how to draw online through his YouTube channel, which has over 2 million subscribers and 240 million views. He has also worked with Google Culture and the BBC on creative drawing projects. He lives in the UK.

Marketing Plans

Generate press and add to Rocky Nook website

Distribute PR to identified, aligned publications and members of the media

Promote product through Rocky Nook site and social media channels

Establish affiliate programs to sell/market new title

Set-up author interviews/webinars with author

Work with author to generate relatable content to share alongside the release of book (how-to, blog post, photo contest, social promotions)

Identify and target key influencers and extend outreach

Links

- ([Author's YouTube, 2.5M subscribers](#))
- ([Author's Facebook, 23K followers](#))

COVER TO COME

THE ANATOMY OF STYLE

PATRICK J. JONES

THE ANATOMY OF STYLE

FIGURE DRAWING TECHNIQUES

By Patrick J. Jones
Foreword by Kiri Leonard

Embark on an artistic journey with Patrick J. Jones, the esteemed multi-award-winning figurative artist and teacher, as he invites you to a life drawing masterclass, where he dives deep into the art of capturing the human figure with unmatched style and confidence. Follow his step-by-step guidance, illustrated with his striking artworks, including his coveted 'Masterclass Study Sheets.' From choosing the right drawing tools to mastering body landmarks, Patrick's invaluable tips create a comprehensive guide for artists of all levels. Join Patrick as he encourages you to delve into an artistic journey, unlocking the anatomy of style and discovering newfound artistic wisdom.

ABOUT THE AUTHOR

Patrick J. Jones is an award-winning sci-fi and fantasy artist and teacher. His work is collected worldwide, and his client list includes companies such as Disney, Lucasfilm and Roc Books. Patrick grew up in Belfast, Northern Ireland, during the worst of the "troubles". Influenced by artists Boris Vallejo and Frank Frazetta, he spent long days in the sanctuary of rooftops, drawing and dreaming of becoming a fantasy artist, to the din of street riots below. Today, Patrick mentors students online from his Brisbane studio in Australia, occasionally travels to draw at the world-renowned New Masters Academy and is an instructor at Proko.com.

FOREWORD BY KIRI LEONARD

Kiri Østergaard Leonard is a fantasy illustrator with an ancient heritage steeped in Nordic myth and folklore. She grew up in the village of Boeslum in Denmark, the oldest kingdom in Europe, where she studied at The Academy of Fine Arts in Aarhus, after which she crossed the Atlantic to attend the Pratt Institute in New York. She currently lives in Austin, Texas, where she works as a full-time artist and illustrator of magical mythology, folklore and fairy tales.

Market:Art techniques, Drawing
Thema Codes: AGZ, AFF
Report Code: NP
Extent: 160 pages
Size: 217 mm (w) x 273mm (h)
Paper:140 gsm
Illustrations: Full colour throughout
Binding: Gatefold cover
Printed in: China
ISBN:9781912740246
Price: £22.99
UK Release:Fall 2024

KEY SELLING POINTS

- Expert, easy-to-follow instructions for drawing the human figure – in any position, from every perspective, in motion and at rest.
- An invaluable resource for any professional, amateur or student artist whose work depicts the human form.
- Packed full of insights, techniques and anecdotes from a modern master of anatomy.
- Fully revised and updated



Princeton University Press
 9780691260662
 0691260664
 Pub Date: 10/29/2024
 On Sale Date: 10/29/2024
 \$49.95/\$63.00 Can./£42.00
 UK/€50.00 EU
 Discount Code: TC
 Hardcover

224 Pages
 122 color + 6 b/w illus.
 Art / Individual Artists
 ART016000

11.5 in H | 9 in W
 Status: **ACTIVE**

Manet

A Model Family

Diana Seave Greenwald, Hilton Als, Nancy Locke, Emily Beeny, Adrienne Chaparro, Kathryn Kremnitzer, Samuel Rodary, Bill Scott, Juliet Wilson-Bureau, Alex Zivkovic

Summary

A groundbreaking and richly illustrated account of the importance of Manet's family to his art

All families are complicated, but the family of Édouard Manet (1832–1883) was more complicated than most. The artist married a piano teacher who worked for his wealthy parents. Her son, born out of wedlock, may have been Édouard's, his father's, or another man's. For all its complexities, Manet's family fueled his creativity. They were his most frequent models, and supported him emotionally and financially. *Manet: A Model Family* is an innovative new exploration of the largely neglected story of the importance of Manet's family to his art.

Presenting new research on works in which Manet depicted family members, *Manet: A Model Family* shows how an understanding of the artist's family sheds crucial light on his artistic career. Manet's mother, wife, stepson, and other relatives—including his sister-in-law, the painter Berthe Morisot—are given long overdue recognition for their roles in Manet's life and work. Leading scholars present technical and archival analysis, including redating *Madame Auguste Manet*, an important, newly conserved painting of Manet's mother. In an essay inspired by that canvas, Pulitzer Prize-winning critic Hilton Als reconsiders Manet's formative relationship with his mother and his bourgeois Parisian roots.

With its original account of Manet's domestic relationships and personal life, *Manet: A Model Family* humanizes the artist and his contributions to the birth of modernism.

Published in association with the Isabella Stewart Gardner Museum

Exhibition Schedule

Isabella Stewart Gardner Museum, Boston
 October 10, 2024–January 20, 2025

Contributor Bio

Diana Seave Greenwald is the William and Lia Poorvu Curator of the Collection at the Isabella Stewart Gardner Museum in Boston. She is the author of *Painting by Numbers: Data-Driven Histories of Nineteenth-Century Art* and, with Nathaniel Silver, *Isabella Stewart Gardner: A Life*. She is also the editor of *Betye Saar: Heart of a Wanderer* and, with Casey Riley, *Fellow Wanderer: Isabella Stewart Gardner's Travel Albums* (all Princeton).

Quotes

"[An] excellent catalog."---**Lloyd Schwartz, WBUR**

"*A Model Family*, somber and intimate, explores the emotional underpinnings of an artist who changed the art world forever."---**Murray Whyte, Boston Globe**

"[A] remarkable book. . . . [*A Model Family*] delves into the fascinating dynamics of Manet's familial connections and through essays from various scholars it paints a complex portrait of both the man and the artist. . . . For those of us who appreciate art in its cultural and historical context, this book offers something really special, a multifaceted exploration of the personal and the professional, the domestic and the public."---**Megan Fox Kelly, Reading the Art World podcast**

Illustrations

— ADVANCED BOOK INFORMATION —

— November 2024 | HB | 324pp, 60 colour illus | £25.00 | 9781911723615 | 216x138mm | History —

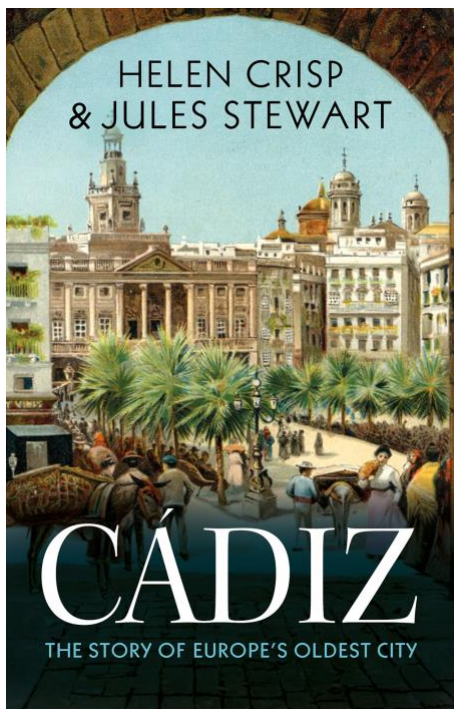

Cádiz

The Story of Europe's Oldest City

Helen Crisp & Jules Stewart

- A captivating portrait of an overlooked Andalusian gem.
- Beautifully illustrated history of Europe's oldest continuously inhabited city
- Site where Europe's first liberal constitution was drafted in 1812 and where Franco's troops first entered in 1936

This is the tale of Western Europe's oldest continuously inhabited city, a 3,000-year history of war and seafaring, culture and commerce, liberalism and resistance.

Helen Crisp and Jules Stewart offer a vibrant account of Cádiz past and present, from its ancient founding myths to its reinvention as a trendy tourist destination. They illuminate Cádiz's experiences under Roman and Moorish rule; explore its centuries of maritime warfare, from Francis Drake to the Battle of Trafalgar; and probe its role in Spain's 'Golden Age' of empire, when it dominated trade with the New World. As Spain's de facto capital during the Peninsular War, Cádiz also produced Europe's first liberal constitution in 1812. And in 1936, it was the port of entry for Franco's troops, mustered to overthrow the Republic.

Cádiz has excited the passions of travellers for centuries. Lord Byron was enchanted by the ladies of the city, whom he described as 'form'd for all the witching arts of love'. Benjamin Disraeli fell in love with Cádiz in 1830, seeing 'Figaro in every street and Rosita in every balcony'. This beautifully illustrated book, the first to tell the full story of this intriguing and extraordinary city, brings its past to life.

Helen Crisp is fascinated by Spain's history, landscapes and lesser-known museums. She is co-author, with Jules Stewart, of *Madrid: Midnight City* and *Strike Up the Band: New York City in the Roaring Twenties*. **Jules Stewart** is a journalist and author, whose thirteen book topics include the NYPD and Prince Albert.

SPAIN
David Cohn

Spain

Modern Architectures in History

David Cohn

Summary

An investigation of the influences and evolution of modern Spain's underappreciated, but foundational, architecture.

Spain's remarkable twentieth-century architecture evolved against a turbulent background of revolution, civil war, dictatorship, and transition to democracy. Architecture played a key role in Spain's struggle out of poverty and isolation, and its search for identity in the modern world.

This book examines Spanish architecture from the roots of Modernism in the eighteenth and nineteenth centuries to the present, analyzing significant figures and their works in relation to their political, social, and cultural contexts, as well as their contributions to architecture as a whole. From the austere, local Modernism of the 1920s, the influence of international trends in the '30s, the renewed, "Organicist" Modernism of the '50s and '60s, to the flourishing public architecture of the late twentieth century and beyond, *Spain* provides a penetrating account of the country's rich and varied built environment.

Contributor Bio

David Cohn is an American architecture critic based in Spain. His books include *Young Spanish Architects* and monographs on the Spanish architects Manuel Gallego and Francisco Mangado.



Reaktion Books
9781789145816
Pub Date: 2/01/2025
\$40.00/£29.00 UK
Paperback

320 Pages
190 halftones
Architecture / History
ARC005080
Series: Modern Architectures in
History
Sales Restrictions: NSA
Internation Pub Date: 2024-07-29
22 cm H | 17.1 cm W | 453.6 g Wt
Status: **FORTHCOMING**

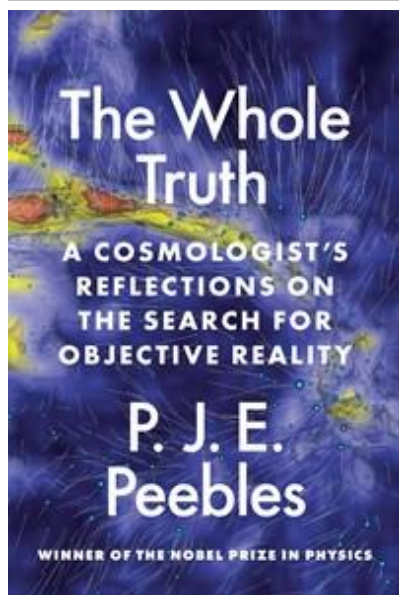

Princeton University Press
9780691231372
0691231370
Pub Date: 10/29/2024
On Sale Date: 10/29/2024
\$22.95/\$28.99 Can./£18.99
UK/€22.99 EU
Discount Code: SP
Trade Paperback

264 Pages
1 b/w illus. 2 tables.
Science / Space Science
SCI015000

9.3 in H | 6.1 in W
Status: **ACTIVE**

The Whole Truth

A Cosmologist's Reflections on the Search for Objective Reality

P. J. E. Peebles

Summary

From the Nobel Prize–winning physicist, a personal meditation on the quest for objective reality in natural science

A century ago, thoughtful people questioned how reality could agree with physical theories that kept changing, from a mechanical model of the ether to electric and magnetic fields, and from homogeneous matter to electrons and atoms. Today, concepts like dark matter and dark energy further complicate and enrich the search for objective reality. *The Whole Truth* is a personal reflection on this ongoing quest by one of the world's most esteemed cosmologists.

What lies at the heart of physical science? What are the foundational ideas that inform and guide the enterprise? Is the concept of objective reality meaningful? If so, do our established physical theories usefully approximate it? P. J. E. Peebles takes on these and other big questions about the nature of science, drawing on a lifetime of experience as a leading physicist and using cosmology as an example. He traces the history of thought about the nature of physical science since Einstein, and succinctly lays out the fundamental working assumptions. Through a careful examination of the general theory of relativity, Einstein's cosmological principle, and the theory of an expanding universe, Peebles shows the evidence that we are discovering the nature of reality in successive approximations through increasingly rigorous scrutiny.

A landmark work, *The Whole Truth* is essential reading for anyone interested in the practice of science.

Contributor Bio

P. J. E. Peebles is a Nobel Prize–winning physicist and the author of several books, including *Cosmology's Century: An Inside History of Our Modern Understanding of the Universe*, *Principles of Physical Cosmology*, *Quantum Mechanics*, and *Physical Cosmology* (all Princeton). He is the Albert Einstein Professor of Science Emeritus in the Department of Physics at Princeton University.

Quotes

"[An] engaging and inviting account of the history of the physical sciences."---**Grace O'Hanlon, *Library Journal***

"This treatment is marked by the author's emphasis on the theory's empirical basis, offering many examples of multiple researchers independently arriving at the same conclusion. Such emphasis distinguishes this book from more popular books on cosmology, and this alone makes it worth having in a university library."---**A. Spero, *Choice Reviews***

Unpublished Endorsements

"The objective reality of this book is that P. J. E. Peebles is an outstanding cosmologist and a fine writer. To learn what he sees as the objective reality of the universe, please read the book!"—**Virginia Trimble, coeditor of *The Sky Is for Everyone: Women Astronomers in Their Own Words***

"Over the past hundred years, our understanding of the structure of our universe as a whole has developed enormously. No one is better qualified to describe these profound and remarkable changes than James Peebles, which he has achieved magnificently in *The Whole Truth*."—**Roger Penrose, author of *Fashion, Faith, and Fantasy in the New Physics of the Universe***

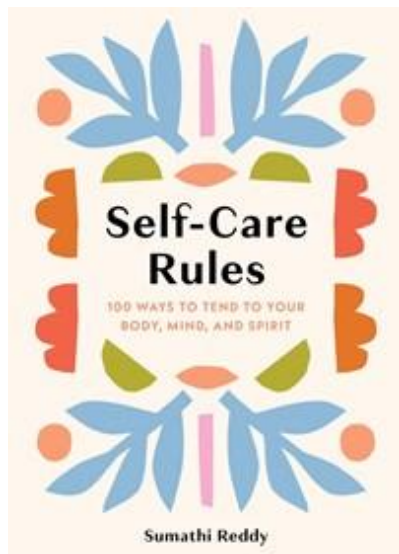

Union Square & Co.
9781454952473
1454952474
Pub Date: 11/5/2024
On Sale Date: 11/5/2024
\$14.99/\$19.99 Can./£12.99 UK
Discount Code: T
Hardcover

144 Pages
all in color
Carton Qty: 44
Print Run: 20K
Body, Mind & Spirit / Inspiration &
Personal Growth
OCC019000
Series: Rules
Territory: World
7 in H | 5 in W
Status: **ACTIVE**

Related Products

Ebooks

9781454952480

Self-Care Rules

100 Ways to Tend to Your Body, Mind, and Spirit

Sumathi Reddy

Key Selling Points

- **HOT TOPIC:** Self-care and mindfulness are evergreen subjects, and many more people have been especially drawn to self-care during the pandemic. According to a study conducted by Birchbox and Kelton Global, 51% of Americans feel burned out, and 76% of Gen Z and 67% of millennials report feeling overwhelmed. Additionally, the Global Wellness Institute projects that the wellness industry will reach a value of \$7 trillion by 2025. This book aims to be a resource that provides ideas for relieving that burnout and stress. Not only that, but hustle culture is on the decline and now more than ever people have been searching for ways to take back their time.
- **BACKED BY SCIENCE, DESIGNED FOR LIFE:** The realm of self-care is filled with pseudo science that can be hard for many to parse. The author's background in health journalism can leave readers confident that the rules in here are not only back by science, but also informed by an expert view of what works and what doesn't in this space.
- **GIFTABLE:** The beautiful illustrations and small size of the book makes it the perfect gift to give those—or yourself!—who want to work on improving their lives or learn something new about themselves. It is also a great gift to give a friend or loved one who is going through a challenging time.

Summary

Featuring 100 rules on self care for Body, Mind, and Spirit, this book will give you the information and tools to you need to easily and successfully implement self-care into your daily routine.

Everyone knows that self care is important—but who has the time? This book, written by a veteran health journalist, with research backed by scientific research, will help you understand and implement healthful, nourishing behaviors in 100 easy-to-follow rules. From improving sleep, to eating mindfully, to combating loneliness, to easing stress, to fostering nourishing human connection this book will shows that not only is self-care for everyone, but can be achieved by everyone by simple, mindful tweaks.

Written and researched by a veteran health journalist and backed by scientific research, this is an essential guide to healthful living for the modern human.

Contributor Bio

Sumathi Reddy is the consumer health columnist for *The Wall Street Journal's* Personal Journal section. She tackles a wide variety of health issues in the "Your Health" column, which runs every Tuesday. Sumathi previously wrote for the *Journal's* Greater New York section as an award-winning metro columnist and author of the weekly "In the Boroughs" column, and covered the food and restaurant industry in NYC, among other topics. She lives in Forest Hills, NY.

Illustrations



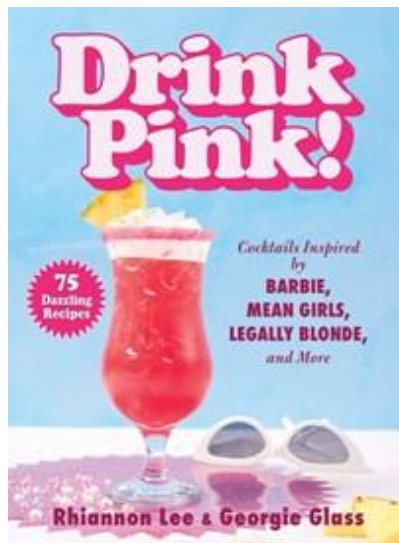

Skyhorse
9781510781818
Pub Date: 5/11/2024
\$19.99/\$26.99 Can./£14.99 UK
Hardcover

176 Pages
Color photographs throughout
Carton Qty: 24
Cooking / Media Tie-In
CKB128000

17.8 cm H | 12.7 cm W | 2 cm T |
408.2 g Wt
Status: **ACTIVE**

Drink Pink!

Cocktails Inspired by Barbie, Mean Girls, Legally Blonde, and More—75 Dazzling Recipes

Rhianon Lee, Georgie Glass

Summary

The ultimate cocktail companion guide for your favorite rom-coms, tearjerkers, and girl power movies.

Including cocktails inspired by *Barbie*, *Mean Girls*, *Clueless*, *Bridget Jones*, *Sex and the City*, *Legally Blonde*, and beyond, this totally fetch cocktail book will introduce you to a dazzling collection of themed drinks that are as sassy, sweet, and stylish as the leading ladies that inspired them.

With easy-to-follow cocktail recipes, complete with glamorous garnishes and tips for flawless presentation, these cocktails are not just delicious but also totally Instagram-worthy. Whether you're glamming up for a night on the town or cozying in with your squad for a movie marathon in your comfiest PJs, this book has a cocktail to suit every mood.

Prepare to be dazzled by glitter, glam, and, of course, the most fabulous shades of pink as you explore the pages of *Drink Pink*—the ultimate chick flick cocktail guide! With over 75 irresistible cocktail recipes, each inspired by the iconic characters and scenes from beloved classics.

Inside, you'll discover:

- **A Barbie-inspired Malibu Dream Drink:** Sip on glamorous pink concoctions inspired by the world's most iconic doll.
- **Mean Magarita:** Raise a toast to Regina George and the Plastics with cocktails that are so fetch!
- **Totally Clueless:** Cher and Dionne would approve of these stylish sips inspired by their Beverly Hills lifestyles.
- **Bridget's Chocolate Delight:** Fall head over heels for this indulgent libation that make you feel like the charming Bridget Jones herself.
- **Dirty Dancing Martini:** A cocktail so irresistible, it'll have you saying, "Nobody puts this drink in the corner!"
- **Carrie Me Away Cosmo:** Join Carrie, Charlotte, Miranda, and Samantha for cosmopolitan cocktails and Manhattan dreams.
- **Blushing Bridesmaids:** Helping you on your way to your own wild night, this cocktail is sure to have you saying, "I do" to another round!
- **Bend and Schapp's Shots:** Channel your inner Elle Woods with cocktails that are as bright and determined as the iconic law student.

So, grab your favorite pink accessories, call your besties, and get ready for a fabulous journey through chick flick cinema with a drink in hand. Cheers to pink, cocktails, and sisterhood!

Contributor Bio

With a passion for both movies and mixology, **Rhianon Lee** combines her love for the silver screen with her expertise in crafting delicious drinks. The author behind *The Unofficial Harry Potter Cocktail Book* and the *The Unofficial Star Wars Cocktail Book*, her latest endeavor promises to infuse your next girls' night with a delightful splash of chick-flick charm. She holds a PhD in chemistry and harnesses this scientific know-how to create some extraordinary creations in the field of mixology. Rhianon resides in the United Kingdom.

Georgie Glass is a photographer and writer who pours her passion into every shot



Weiser Books
9781578638611
1578638615
Pub Date: 4/11/2024
On Sale Date: 4/11/2024
\$24.95
Cards

80 Pages
79 Full-Color Tarot Cards
Carton Qty: 24
Body, Mind & Spirit / Divination
OCC024000
13.3 cm H | 8.3 cm W | 353.8 g
Wt
Status: **ACTIVE**

Related Products

Display

The Cosmic Slumber Tarot
9781454943099 \$24.95

Tarot of the Cosmic Seed

(79 Full-Color Cards and 80 Page Booklet)

Lalania Simone

Key Selling Points

- Tarot was made with a focus and effort to decolonize the tarot, remove outdated ideas of hierarchy, and shift ingrained gender norms
- Created to represent the beauty and diversity of people and cultures around the world
- Twenty-third card added to the Major Arcana—The Cosmic Seed
- Teal Foil used on box cover and card edging.

Summary

Connect with Your Inner Wisdom and the Richness of the World We Live In

In an effort to decolonize the tarot, remove outdated ideas of hierarchy, and shift ingrained gender norms, Lalania Simone, founder of Alchemy Ritual Goods, has created a lush and vibrant deck with unique imagery and symbolism and an array of people and cultures. Having renamed the royalty cards—including the Hierophant, Emperor, Empress, and the court cards—Lalania has expanded their interpretation into energy signatures rather than personality types. The result is a deeply diverse spiritual tool, a bridge to the mysterious and the esoteric, as well as a guide to the everyday. Using the Rider-Waite-Smith tradition as a foundation, this deck offers a twist: there is a twenty-third card added to the Major Arcana—The Cosmic Seed, a representative of us all as infinite, cosmic spirits, enmeshed in sacred flesh for a time on this Earth.

“A vibrant collage deck, rich in dreamlike imagery, cultural diversity, and mystical symbolism.” —Little Red Tarot

“If there ever was a deck to get me back to deeply diving into the cards and sharing them with folks, this would be the one. It causes my Libra Sun to just sing with how absurdly lovely it is.” —Tarot of the QTPOC

This deluxe package contains seventy-nine gilt-edge full-color cards and a sixty-four-page guidebook.

Contributor Bio

Lalania Simone is a mystic, multifaceted artist, and mother devoted to a path of liberation and awakening. She understands the power of frequency and is dedicated to raising the vibration of the planet. She holds certifications in reiki and yoga and is a meditation teacher. Lalania is the creatrix of *Tarot of the Cosmic Seed*, *The Oracle of Awakening*, and the upcoming *Wise Earth Medicine Tarot*. She also creates sacred crystal talismans to amplify particular energies.

Lalania is one of the co-owners of Alchemy Ritual Goods—a metaphysical store in Denver that includes an Ancestral Medicine Clinic, a sliding-scale clinic offering multiple modalities dedicated to healing and spiritual liberation.

Excerpts

What is the Cosmic Seed?

The Cosmic Seed is representative of you and I. We are infinite, cosmic spirits, enmeshed in sacred flesh for a time on this magnificent planet earth. We are seeds of pure potential, here to grow and learn and share our magic with each other.

Tarot of the Cosmic Seed is a vibrant and diverse spiritual tool, a bridge to the mysterious and the esoteric, as well as a guide to the everyday.

This deck was lovingly created over eleven months using a digital process of modifying and layering textures, colors and images with hand drawn elements. It uses the Rider Waite Smith tradition as a foundation. Several major arcana cards have been renamed,



Crossed Crow Books
9781959883692
1959883690
Pub Date: 12/12/2024
On Sale Date: 12/12/2024
\$29.95
Cards

60 Pages
40 Full-Color Cards
Body, Mind & Spirit / Witchcraft
OCC026000

17.8 cm H | 10.8 cm W
Status: **FORTHCOMING**

Related Products

Display

Esoteric Empathy
9780738749174 \$19.99

A Gothic Witch's Oracle

(40 Full-Color Cards and 60-Page Guidebook)

Raven Digitalis, John Santerineross

Key Selling Points

- This deck is designed for mystical and magickal practitioners who are especially drawn to dark art and subculture.
- Created with shadow work in mind, this deck can help guide your journey as you work with your shadow aspect.
- Encourages readers to embrace their own creativity and intuition when performing divination.

Summary

Author Raven Digitalis has teamed up with world-renowned Gothic photographic artist John Santerineross to create a divinatory experience like no other. *A Gothic Witch's Oracle* invites readers to a safe, mystical, and empowering space of dark art and potent magickal wisdom.

In the spirit of his Empath's Oracle deck, Raven Digitalis has created *A Gothic Witch's Oracle* in collaboration with world-renowned photographic artist John Santerineross. This deck is the final piece of Raven's "shadow trilogy," the first two of which were the bestselling *Goth Craft* and *A Witch's Shadow Magick Compendium*.

Shadow work is an integral part of advancing on the path of witchcraft. This deck is especially relevant to readers who are not afraid to dive deeper into the workings of the unconscious mind.

The art of divination is, by its very nature, an act of exploring the unseen. This deck takes the journey to the next level.

These forty cards and accompanying guidebook encourage readers to embrace their own creativity and intuition when performing divination.

By exploring dark and mysterious aspects of life, we can better come to know ourselves and discover our unique place in the world.

Themes explored within the cards include:

- Dark art and self-expression
- The magick of makeup and fashion
- Music as a healing force
- Exploring labels, the ego, and self-identity
- Death magick and ancestral work
- Shadow spells and ceremonies
- Body modification as sacred ritual
- Social boundaries and conditioning
- Contemplating gender and sexuality
- Working with depression and anxiety
- Self-confidence and personal empowerment

Contributor Bio

Raven Digitalis (Missoula, Montana) is the author of *The Empath's Oracle*, *The Everyday Empath*, *Esoteric Empathy*, *Shadow Magick Compendium*, *Planetary Spells & Rituals*, and *Goth Craft* (Llewellyn Worldwide). Originally trained in Georgian witchcraft, Raven has been a witch since 1999, a Priest since 2003, a Freemason since 2012, and an empath all of his life. He holds a degree in cultural anthropology from the University of Montana, co-operated a nonprofit pagan temple for sixteen years, and is also a professional tarot reader, DJ, card-carrying magician, and animal rights advocate.



Mystic's Imaginarium Oracle Deck

(44 Full-Color Cards and 90-Page Guidebook)

Jen McCarty, Stephanie Wicker-Campbell

Key Selling Points

- Whether you're new to Neville's wisdom or a loyal follower, this deck aims to be a trusted companion on the path to becoming a master manifestor, offering unwavering confidence and a deep understanding of Neville's principles to transform reality and manifest desires.
- 44 radiantly designed cards capture the imagination and wonder of Neville Goddard's timeless wisdom paired with a full-color guidebook.
- Crafted on high-quality card stock with a matte finish, the cards are not only visually stunning but also easy to shuffle, enhancing the overall tactile experience. Intended for daily use, these powerful tools are ideal for newcomers and those familiar with Neville's wisdom.



Muse Oracle Press
 9780645885064
 0645885061
 Pub Date: 5/11/2024
 On Sale Date: 5/11/2024
 \$26.95
 Cards

90 Pages
 44 Full-Color Cards
 Carton Qty: 30
 Body, Mind & Spirit / Inspiration &
 Personal Growth
 OCC019000
 14 cm H | 8.9 cm W | 353.8 g Wt
 Status: **ACTIVE**

Related Products

Display
 Super Attractor 9781401957827
 \$21.99

Summary

Mystic's Imaginarium Oracle Deck is a unique and mystical card deck designed to master manifestation and explore the depths of imagination. It acts as a guiding light on your journey to becoming a master manifestor, weaving its way into your subconscious through its radiant and eclectic imagery. The *Mystic's Imaginarium's* collage style, with its layered elements and evocative color combinations, is as powerful as it is mesmerizing. Journey into the mind of Neville Goddard, curated by author Jen McCarty, with the sole purpose of guiding souls to eternal wisdom and a deeper understanding of the infinite. This forty-four-card deck is accompanied by a full-color guidebook, enriched with activations, all interwoven by the timeless teachings of Neville Goddard.

Contributor Bio

Jen McCarty is a leading luminary in the ascension and twin flame community. Jen teaches and guides pioneering and leading changemakers in the spiritual community. Jen experienced a life changing kundalini awakening aged twenty-one in the Himalayas in northern India chanting the mantra Om Namah Shivaya from that moment she passed over the threshold from 3D consciousness to stabilizing into 5th dimensional consciousness. She is now forty-four years old and has devoted her whole adult life to the spiritual awakening path, mastering many disciplines along the way. She is a fully awakened spiritual teacher, deeply and highly skilled at facilitating a space for all those who she comes into contact with, to awaken spiritually. She explains this using the analogy of a candle: "When a candle is lit it is very, very easy to light other candles."

Links

- [Instagram 5k followers](#)
- [Author site](#)

Illustrations





Creatrix Awakened Oracle Deck

Fierce Feminine Frequency Leaders (33 Full-Color Cards and 126-Page Guidebook)

Shannon Van Den Berg, Stephanie Wicker-Campbell

Key Selling Points

- The Oracle Deck is for individuals seeking guidance, inspiration, and activation in feminine leadership, sovereignty, and the embodiment of new earth wisdom. Ideal for those ready to embrace their own leadership qualities and align with the emerging frequencies on the planet.

Summary

Creatrix Awakened Oracle Deck whispers the wisdom of fierce feminine frequency leaders, guiding the way to the golden age with a path illuminated by love and sovereignty. They stand as luminaries among leaders, passionately advocating for their soul mission, the children, and their ancestors, holding their wild hearts wide open in devoted service to humanity. Amidst the world's perceived crumbling, they step into even bolder action and soul-centered beingness, remaining the calm eye in the storm, unwaveringly envisioning a paradise and interconnected way of living that they anchor through their very presence. These potent goddesses of creation weave a tapestry of ancient and galactic wisdom in every heartbeat. Each cell within them is a sacred devotion to the infinite possibilities and the rising frequencies of the emerging earth. They embody the forces of nature, true visionaries embracing their sacred feminine power, beckoning forth all souls ready to be activated into their leadership and sovereignty for the grand collective rising.

Contributor Bio

Shannon Van Den Berg is a dedicated shaman guiding the awakening of fellow starseeds and new Earth feminine leaders toward the golden age. Her journey on Earth revolves around empowering others and imparting ancient ancestral wisdom, fostering sovereign feminine leadership among emerging leaders.

Links

- [Author site](#)

Illustrations



Muse Oracle Press
9780645885040
0645885045
Pub Date: 5/11/2024
On Sale Date: 5/11/2024
\$26.95
Cards

126 Pages
33 Full-Color Cards
Carton Qty: 36
Body, Mind & Spirit / Inspiration &
Personal Growth
OCC019000
14 cm H | 8.9 cm W | 290.3 g Wt
Status: **ACTIVE**

Related Products

Display

Wild Woman Oracle
9781925946833 \$24.95

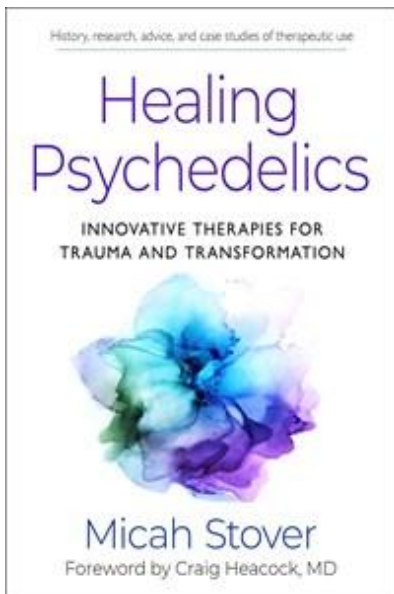

Hampton Roads Publishing
9781642970647
1642970646
Pub Date: 4/11/2024
On Sale Date: 4/11/2024
\$21.95
Trade Paperback

240 Pages
Carton Qty: 32
Body, Mind & Spirit / Entheogens
& Visionary Substances
OCC039000
22.9 cm H | 15.2 cm W | 290.3 g
Wt
Status: **ACTIVE**

Related Products

Display

Consciousness Medicine
9781623173494 \$17.95

Healing Psychedelics

Innovative Therapies for Trauma and Transformation

Micah Stover, Craig Heacock

Key Selling Points

- Healing with MDMA, psilocybin, and guided psychotherapy
- Interest in psychedelics therapies continues to rise
- Three in five American voters support legalizing psychedelic therapy, according to UC Berkeley's Center for the Science of Psychedelics
- Addresses the potential for both the healing as well as harm inherent in this therapy
- Author has contacts with many psychedelics media including DoubleBlind, healthywomen.com, womenonpsychedelics.org, and has appeared on many podcasts
- World Health Organization reported the pandemic triggered a 25% increase in prevalence of anxiety and depression
- Depression within the US tripled from 9% to 29% and has continued to rise to 33%. In the US, 1.8 million people are in therapy served by 55,000 therapists (Boston Univ School of Public Health)

Summary

A certified psychedelic therapist explores the deeper healing offered by psychedelics to those working through trauma.

“Micah has created a must-read for anyone curious about the healing power of psychedelics. *Healing Psychedelics* demystifies the process and emphasizes safety and effectiveness, making it an essential guide for both new explorers and seasoned practitioners.”

—Jessika Lagarde, psychedelic-assisted medicine facilitator, integration coach, and cofounder of Women On Psychedelics

Psychedelics are showing great promise as a new way to heal trauma and improve emotional wellness. Studies reveal that they can be effective in reducing PTSD, anxiety, and depression symptoms, even in cases that are resistant to other treatments. Stover offers a comprehensive and informative guide for both professionals and patients who are interested in learning more about psychedelic-assisted therapy.

Each chapter reveals a vignette taken directly from the psychedelic space that shows the medicines (medium and macro-doses of MDMA, psilocybin, ketamine, and cannabis), why they were chosen, and the process used for transformation during the sessions. Stover weaves in wisdom from indigenous and Mexican healers and practitioners with application exercises, writing prompts, and journal entries to deepen the reader's healing journey. These exercises are applicable to all readers, whether you are working on your own or with a therapist.

Healing Psychedelics shows the complete process, enabling the reader to safely unlock the power of psychedelics to heal trauma and transform their life for a brighter future.

Contributor Bio

Micah Stover's introduction to psychedelic therapy followed a traumatic pregnancy and birth that unearthed a reservoir of unresolved trauma. The journey to heal those wounds transformed her life. In 2022, Micah began training with the Psychedelic Somatic Institute in Denver, Colorado. She completed the apprenticeship level 1 and 2 certification and is finalizing her certificate of mastery. In Micah's current role as a certified psychedelic somatic therapist, she hosts individual healing retreats and trains psychedelic practitioners.



Weiser Books
9781578638376
1578638372
Pub Date: 4/11/2024
On Sale Date: 4/11/2024
\$18.95
Trade Paperback

240 Pages
24 rune images and 5 layouts
Carton Qty: 32
Body, Mind & Spirit / Divination
OCC045000
22.9 cm H | 15.2 cm W | 290.3 g
Wt
Status: **ACTIVE**

Related Products

Display

Queering the Tarot
9781578636488 \$16.95

Queering the Runes

Reclaiming Ancestral Wisdom in Rune Magic and Mythology

Siri Vincent Plouff, Lara Vesta

Key Selling Points

- The Elder Futhark create a beautiful system of divination, though finding good information about them can be difficult-especially for queer, progressive, modern querents.
- The book will focus not only on folk practices of the Nordic peoples, but it will also pave the way for understanding how to work with runes and heal from patriarchy and white supremacy.
- Norse mythology includes an incredible diversity of gender and sexual expression, but this has been largely excluded from books published on contemporary heathenry or runic divination.
- The Norse path has a rich potential for queer liberation. There is currently no rune book that explicitly talks about the queer nature of the runes and the way the runes defy the binary.
- The introduction lays the groundwork for the book and addresses the elephant in the room-the author confronts white supremacy in the rune magic revival and provides some steps forward for ethical rune work that isn't exclusively white, patriarchal, or supremacist.

Summary

Queering the Runes is a contemporary, inclusive, and forward-thinking approach to the runes that focuses on finding queer experience, life, and joy in the Elder Futhark. Siri comes to the runes as a queer, nonbinary reader, and presents a path for reclaiming the ancestral wisdom and mystery of the runes in a way that can provide insight and understanding of their sacred nature for masculine, feminine, and nongendered aspects of self. Written as a love letter to the runes, the gods, and the people who follow the Nordic path, *Queering the Runes* presents an alternative approach to the runes—one that creates a gentle container for those who want to follow this heathen path. Based on the author's personal gnosis, as well as deep academic research on runes and Nordic culture, this book explores the root culture of the runes, both in terms of myth and of lived, real folkloric experience, and paves the way for understanding how to work with runes disencumbered from patriarchy and white supremacy.

Siri Vincent Plouff presents the traditional meanings of the runes, then helps the reader to queer the runes in their own way. Included are the lore associated with each rune, exercises to apply them to modern life, activities to engage with the runes (layouts, castings, and galdr), and advice on how to use the runes for divination. Throughout, the author provides journal prompts meant to help the reader channel the energy of specific runes, to get to know their energy, as well as to use the runes to help them move forward in a journey of self-discovery.

Queering the Runes seeks to blow open perceptions of the runes, exploring them as active, living symbols available to all, as well as the inherent connection with ancestral magic that comes with rune work.

Contributor Bio

Siri Vincent Plouff (they/them) is a Nordic witch, rune reader, tarot reader, and coauthor with Cassandra Snow of *Lessons from the Empress: A Tarot Workbook for Self-Care and Creative Growth*. As an unabashedly queer person, they are constantly interrogating runes and Nordic practices through a unique lens of sexual and gender identity. They see witchcraft as a way to break out of expectations and live outside of society. Siri is the brain behind the radical heathenry podcast *The Heathen's Journey*. They teach about the runes, tarot, and witchcraft, and their signature course is the Radical Runes Course, a six-week deep dive into the runes.

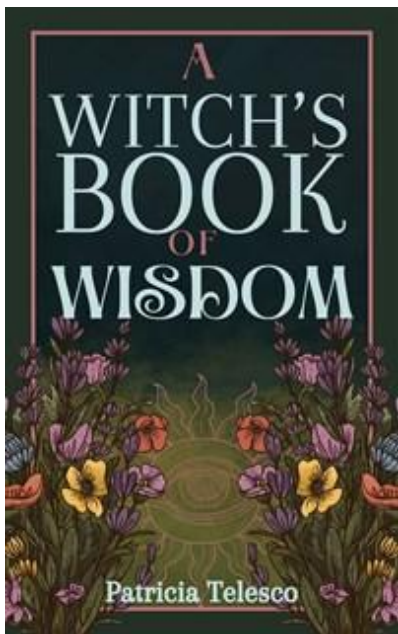

Crossed Crow Books
9781959883548
1959883542
Pub Date: 5/11/2024
On Sale Date: 5/11/2024
\$21.95
Trade Paperback

224 Pages
Carton Qty: 40
Body, Mind & Spirit / Witchcraft
OCC026000
21.6 cm H | 13.3 cm W | 362.9 g
Wt
Status: **ACTIVE**

Related Products

Display

Your Book Of Shadows
9780806520711 \$12.95

A Witch's Book of Wisdom

Patricia Telesco

Key Selling Points

- Get your questions answered! Telesco provides her insight into everything from amulets and charms to cleansing.
- Merges together ancient wisdom with modern magic to inspire your personal practice.
- Provides a nurturing, sound, practical, and fun-loving outlook on magic and spirituality as they intertwine with your everyday life.

Summary

A Witch's Book of Wisdom is the ultimate grimoire of folk spells, offering a unique selection of magical solutions to many of life's problems.

Hearken back to a time when the solution to life's problems could be discovered by having a chat with the local wise person. These folks were undoubtedly skilled in the magical arts and knew just what to prescribe for their client, depending on whatever obstacle they happened to be facing at the time. In the modern era, the proverbial village has grown into a global community, leaving many curious witches to their own devices when it comes to finding the magical solution to a problem.

Learn magical techniques to overcome fear and find lost items. Discover the magic of pathworking and learn how to work with poppets. Explore the magic of knots, then sneak away to the kitchen for a bit of kitchen witchery. Step back in time and allow the simple ways of magic to unfold in your everyday life.

Contributor Bio

Patricia Telesco (Trish) has been a part of the neo-pagan community for several decades. During that time, she penned many memorable titles, including *A Victorian Grimoire*; *Goddess in My Pocket*; *Spinning Spells*, *Weaving Wonders*; and *A Kitchen Witch's Cookbook*.

Excerpts

Archetype of the Wise Person

When I think of a village wise person, my mind wanders to a remote place on the edge of the woods. There, a man or woman stands surrounded by animals and harvested herbs, concocting something in an iron pot over a well-tended hearth fire. This person lives alone by choice, their only company being nature and the love of the work. Perhaps this image is romanticized, but it is part of what has become an archetype in the metaphysical movement as surely as that of a Druid or Shaman.

Why consider it an archetype? Because it's an image to which many Wiccans and neo-Pagans point as being a prototype that expresses the heart and soul of where we've come from historically. It is also a positive role model for where magical lifestyles may go in the future. Living close to the land (or at least being respectful of the Earth), being skilled in our arts, helping our communities, and being at peace with self and Spirit are worthy treasures to gather from this simple but sublime portrait. But I'm getting ahead of myself.

In exploring the legacy of the Cunning Person, I've relied mostly on European history, as that's where this archetype seems to appear regularly. It is quite certain that other cultures had expressions of this type, too, but they achieved little more than passing mention in

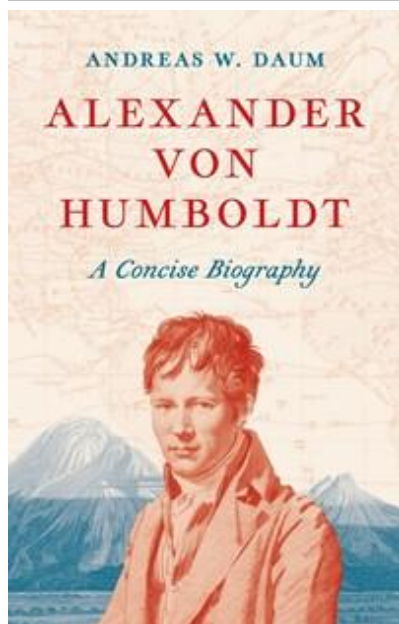

Princeton University Press
 9780691247366
 0691247366
 Pub Date: 10/22/2024
 On Sale Date: 10/22/2024
 \$24.95/\$32.00 Can./£20.00
 UK/€24.99 EU
 Discount Code: TC
 Hardcover

224 Pages
 10 b/w illus. 4 maps.
 Biography & Autobiography
 / Science & Technology
 BIO015000

8 in H | 5 in W
 Status: **ACTIVE**

Alexander von Humboldt

A Concise Biography

Andreas W. Daum, Robert Savage

Summary

An engaging account of the life and work of the legendary polymath Alexander von Humboldt

In this lucid biography, Andreas Daum offers a succinct and novel interpretation of the life and oeuvre of Alexander von Humboldt (1769–1859). A Prussian nobleman born into the age of European Enlightenment, Humboldt was a contemporary of Napoleon, Simón Bolívar, and Charles Darwin. As a naturalist and scholar, he traveled the world, from the Americas to Central Asia, and recorded his observations in multiple volumes. Humboldt is still admired today for his interdisciplinary outreach and ecological awareness.

Moving beyond the conventional views of Humboldt as either intellectual superhero or gentleman colonizer, Daum's incisive account focuses on Humboldt in the context of the tumultuous period of history in which he lived. Humboldt embodied the contradictions that marked the age of Atlantic Revolutions. He became a critic of slavery and embraced the emerging civil society but remained close to authoritarian rulers. He dedicated his life to scientific research yet was driven by emotional impulses and pleaded for an aesthetic appreciation of nature. Daum introduces a man passionately striving to establish a "cosmic" understanding of nature while grappling with the era's explosion of knowledge.

This book provides the first concise biography of Humboldt, covering all periods of his life, exploring his personality, the vast range of his works, and his intellectual networks. Daum helps us understand Humboldt as a seminal historical figure and illuminates the role of science at the dawn of the global world.

Contributor Bio

Andreas W. Daum is professor of history at the State University of New York (SUNY) at Buffalo and a recipient of the Humboldt Research Award. He is the author of *Kennedy in Berlin* and *Popularizing Science in the Nineteenth Century* (in German), among others.

Quotes

"The key virtue of this biography is its concision, and Daum does an admirable job of sorting through Humboldt's numerous contradictions. . . . This gets the job done."
 -Publishers Weekly

Unpublished Endorsements

"Andreas Daum has distilled his deep knowledge of Alexander von Humboldt into a short, very readable biography. His nuanced account does full justice to a complex, multifaceted figure. The author elegantly weaves together life and times in a book that is scholarly and engrossing. The different phases of a long life are expertly managed, there is generous direct quotation, and Daum's arguments are both fresh and convincing. I recommend the book highly as the perfect introduction to its complex subject."—**David Blackbourn, author of *The Conquest of Nature and Germany in the World: A Global History, 1500–2000***

"At the time of his death in 1859, Alexander von Humboldt was a global celebrity as a paragon of scientific travel, a master of several disciplines, and an inveterate intellectual networker across Europe and the Atlantic. Avoiding both hero worship and debunking, Andreas Daum succeeds in capturing the many facets of this paradoxical man. A marvel of concision and readability."—**Jürgen Osterhammel, author of**



Tiberius and His Age

Myth, Sex, Luxury, and Power

Edward Champlin, Robert Kaster

Summary

A radical new portrait of the infamous Roman emperor

Rome's second emperor, Tiberius (42 BCE–CE 37), has traditionally been seen as a villainous hypocrite—treacherous, grasping, vindictive, and depraved. But in *Tiberius and His Age*, Edward Champlin draws on vast and diverse evidence to show that Tiberius was—and was seen by contemporaries to be—recognizably human and far more complex than the monster of the hostile tradition that began with Tacitus and Suetonius.

Focusing on the overlapping themes of luxury, sex, power, and, especially, myth, *Tiberius and His Age* examines Tiberius's standing as a folkloric figure in the Roman popular imagination and his conscious use of mythological themes to consolidate his power. It argues that the striking stories of Tiberius's sexual depravity, which literary sources passed on to later generations, are ultimately incoherent fictions, the work of a brilliant fantasist who hated the emperor. The book's portraits of three important figures in Tiberius's circle—the gourmands Asellius Sabinus and Marcus Apicius and the emperor's lieutenant, Sejanus—provide new perspectives on the emperor and his age. Tiberius's passions for astrology, gastronomy, and mythology, which have often been seen as eccentric scholarly diversions, are revealed instead to be central to contemporary Roman debates and keys to understanding his personality, his power, and the lasting image of Roman emperors.

Incisive, witty, and original, *Tiberius and His Age* presents a startlingly new picture of Tiberius and the culture and politics of the early Roman Empire.

Contributor Bio

Edward Champlin is professor of classics and Cotsen Professor of the Humanities, emeritus, at Princeton University. His books include *Nero*, *Final Judgments: Duty and Emotion in Roman Wills, 200 B.C.–A.D. 250*, and *Fronto and Antonine Rome*. **Robert A. Kaster** is the Kennedy Foundation Professor of Latin, emeritus, at Princeton. He is the author of, most recently, *How to Do the Right Thing: An Ancient Guide to Treating People Fairly* (Princeton).

Unpublished Endorsements

"Wonder, once banished from classics, has been brought back by Edward Champlin, who tells a golden tale. There cannot be a classicist in the world who does not secretly wish to have written this book. Through the keyhole of a tradition that knew the cruel and twisted Emperor Tiberius as a wise man and a warlock, Champlin sees imperial Rome as a cabinet of curiosities wholly unsuspected by traditional historians. Tiberius the sorcerer! All praise to the man who conjured up the emperor's shade: Champlin is a mage among the magi."—**J. E. Lendon, author of *That Tyrant, Persuasion: How Rhetoric Shaped the Roman World***

"*Tiberius and His Age* presents a bold new cultural, social, and political history of this enigmatic but pivotal emperor. The book is distinctive both in its evidence, much of which will be unknown even to specialists, and in the overall picture of Tiberius that emerges from Edward Champlin's analysis—a more complex, and more sympathetic, figure than that of the traditional narrative. This is a model of how one can write exciting ancient history from a carefully curated blend of familiar and obscure literary sources."—**Carlos F. Noreña, University of California, Berkeley**

"*Tiberius and His Age* brings into focus a whole series of texts that don't usually get much attention, but that offer insights into the culture and society of the era."—**Alison**



Princeton University Press
9780691139241
0691139245
Pub Date: 11/5/2024
On Sale Date: 11/5/2024
\$38.00/\$48.00 Can./£32.00
UK/€38.00 EU
Discount Code: S
Hardcover

288 Pages
History / Ancient
HIS002020
9.3 in H | 6.1 in W
Status: **ACTIVE**



Union Square & Co.
9781454956082
1454956089
Pub Date: 10/22/2024
On Sale Date: 10/22/2024
\$18.99/\$24.99 Can./£16.99 UK
Discount Code: T
Jigsaw Puzzle

full-color 500-piece puzzle
Carton Qty: 12
Print Run: 15K
Games & Activities / Puzzles
GAM007000
Territory: World
10 in H | 8 in W
Status: **ACTIVE**

Mrs. Dalloway 500-Piece Jigsaw Puzzle

Malika Favre

Key Selling Points

- **A GIFT FOR THE BOOK LOVER:** Forget Austen and Dickens, Woolf is where it's at! This distinctive package and beautiful art is an eye-catching purchase for book lovers everywhere.
- **SUPERSTAR ARTIST:** Malika Favre's work is world renowned for its starkly beautiful and stunning use of color and shape. A puzzle by her presents fans with a new way to connect with her art.
- **BESTSELLING DESIGN:** The stunning art for *Mrs. Dalloway* is Malika's bestselling print—this deluxe puzzle captures all the boldly graphic beauty of her art, here adapted with extra elements for better puzzling.
- **PACKAGE CONCEPT:** Complete with a rounded "spine" and hinged lid, this deluxe 500-piece jigsaw puzzle is housed in a box that looks like a book.

Summary

A 500-piece jigsaw puzzle adaption of Malika Favre's stunning cover art for Union Square & Co.'s Signature Classics edition of *Mrs. Dalloway*, packaged in a unique keepsake box that is designed to look like a book.

Stored in a keepsake box that opens like a book, Malika Favre's stunning cover art from Union Square and Co.'s edition of *Mrs. Dalloway* is adapted here—with extra elements to make for a better solving experience—into a charming 500-piece jigsaw puzzle for fans of both Malika's graphic art and lovers of classic literature.

Contributor Bio

Malika Favre is a French artist based in Barcelona. Her bold, minimal style—often described as Pop Art meets OpArt—is a striking lesson in the use of positive/negative space and color. Her unmistakable style has established her as one of the world's most sought-after graphic artists. Along with her work on our Signature Classics series, Malika's clients include *The New Yorker*, *Vogue*, BAFTA, and Sephora, among many others.

Illustrations

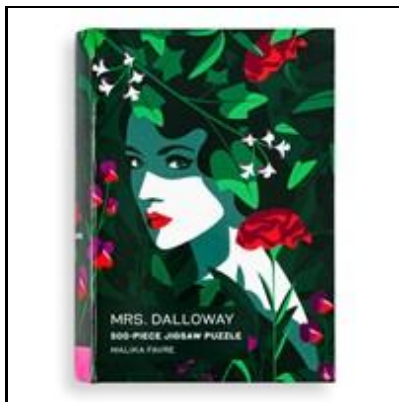



Union Square Gift
9781454955450
1454955457
Pub Date: 11/5/2024
On Sale Date: 11/5/2024
\$18.99/\$24.99 Can./£18.99 UK
Discount Code: T
Hardcover

240 Pages
Carton Qty: 18
Print Run: 15K
Games & Activities / Guided Journals
GAM021000
Territory: World
8.3 in H | 5.7 in W
Status: **ACTIVE**

The Storyteller's Weekly Journal

A Guided Planner to Take Your Story from Concept to Completion in 12 Months

Mary Weber, C.J. Redwine

Key Selling Points

- **POPULAR SUBJECT:** The Author's Guild recently reported that more people are writing and publishing books than ever before. Self-help books and journals on writing are popular, but most are older, with dated designs. This one has a unique take, with advice, tools, and prompts for a whole year's worth of inspiration—and it is perfectly timed to release for National Novel Writing Month (NaNoWriMo), in November.
- **EXPERT AUTHORS:** Both authors are seasoned published writers, with years of experience through their ancillary business, the Writer's Sanctuary.
- **PACKAGE SUMMARY:** The PLC journal will be light enough for writers to take it with them wherever they go, but sturdy enough to last the year and more. It will include a ribbon marker and elastic closure for ease of use, and a fresh two-color interior design.

Summary

A beautiful guided journal designed to help authors take their story from concept to completed manuscript over the course of one year.

The brainchild of experienced authors and entrepreneurs Mary Weber and C. J. Redwine, this step-by-step guide will help aspiring novelists grow their projects from the seed of an idea into a polished manuscript. It contains proven tools drawn from multiple schools of productivity and writing thought to help writers stay motivated through each phase of the writing process—even after that initial burst of excitement and momentum is replaced by the daunting reality of all the work that lies ahead. Weber and Redwine combine these tools with the holistic approach of a book coach to provide the structure writers need to successfully finish a project while producing their best work, in a healthy and sustainable fashion. Through the daily use of this journal, they'll learn how to turn the bigger picture into actionable milestones and deadlines, making a process that can often feel overwhelming more accessible and achievable. The journal is filled throughout with:

- Progress trackers
- Craft exercises on idea development, outlining, writing fundamentals, and self-editing
- Inspirational quotes
- Self-care suggestions
- In-depth training on creating queries, proposals, and pitch materials
- Pro tips
- and more

The Storyteller's Journal is everything writers love about bullet journals, daily planners, and writing craft books--all in one beautiful package.

Contributor Bio

C. J. Redwine is a *New York Times* bestselling author of ten novels, a public speaker, a writing coach, and a marketing consultant. She lives in South Carolina.

Mary Weber is a bestselling author of six novels, a marketing and branding specialist, a public speaker, a writing coach, and a business consultant. She lives in California.

Together, Mary and C.J. run the Writer's Sanctuary, where they host sold-out courses, retreats, a virtual university, and the popular Red Herrings Society, a monthly

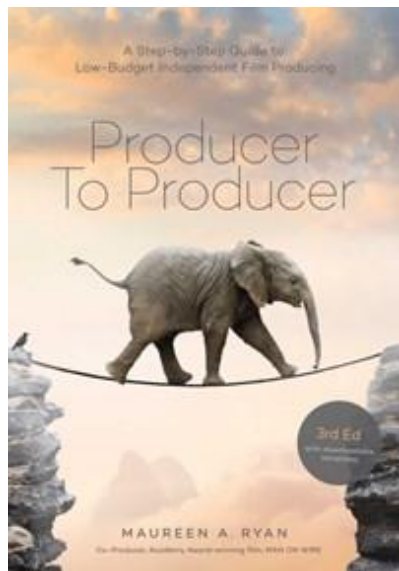

Michael Wiese Productions
9781615933587
1615933581
Pub Date: 12/11/2024
On Sale Date: 12/11/2024
\$44.95/\$58.95 Can.
Trade Paperback

380 Pages
25 Illustration(s)
Carton Qty: 10
Performing Arts / Film
PER004040
25.4 cm H | 17.8 cm W
Status: **FORTHCOMING**

Related Products

Also Available

Producer to Producer 2nd edition
9781615932665 \$41.95

Producer to Producer -3rd edition(3rd Edition) A Step- by- Step Guide to Low Budget Independent Film Producing

Maureen A. Ryan

Key Selling Points

KEY SELLING POINTS

- This edition will reflect all of the changes to the film industry in the last few years and will encompass what has changed in 2023's new WGA, DGA and soon SAG-AFTRA agreements and how they address other changes in the film business.
- This book is purchased multiple times by the working professionals as each book is read, marked up, shared for each individual project.
- This book is often purchased for every new production team as they embark on new projects.
- 3rd edition and updated version of best-selling handbook with additional chapter and latest film industry information.
- Top selling textbook for filmmaking and film production classes throughout the U.S. Required reading for the majority of university course syllabi.
- After you read this book you can go out and make your first film or make your tenth film better.
- The companion website has free downloadable production and budget templates and lots of reference information.

Summary

The comprehensive bible for low-budget, independent film producing for emerging and professional producers.

Designed to use for production meetings with every aspect of the film producing process outlined in detail, including checklists to keep you on track, from pre-production to the first day of principal photography through to post production and delivery.

Contributor Bio

New York-based producer Maureen A. Ryan is a powerhouse in narrative and documentary feature film. From Academy Awards to Emmys to Oscars, Ryan has contributed to many projects demonstrating her knowledge and skill set in the industry. As the Professor of Professional Practice at Columbia University's Graduate Film program, Ryan holds an MFA (Film) from Columbia's School of the Arts and a BA (Economics) from Boston College.

Quotes

"This does what no book on production has done before—you actually can go out and make a movie after you read it. Ryan is one of the best independent producers working today and this book will show you why. Like her, it's thorough, thoughtful, and highly enjoyable. Whether you are a novice or a professional, there is much to learn here." —**Ben Odell, producer, *Radical, Acapulco*, cofounder 3Pas Studios**

"This isn't just another book about how to produce a film; this is THE book about how to produce a film. No other book comes close to the detail, organization, and vast amount of knowledge in this volume. I've assigned Ryan's book as a professor, and I've used it as a resource for myself as a producer. If you want to produce movies, *Producer to Producer* is as essential as a pair of comfortable shoes." —**Jack Lechner, producer, *Blue Valentine, The Fog of War*; Chair/professor, Columbia**



Assembly Press
9781738009824
1738009823
Pub Date: 10/15/2024
On Sale Date: 10/15/2024
\$17.95/£12.99 UK/€15.99 EU
Discount Code: TP
Trade Paperback

280 Pages
Carton Qty: 44
Sports & Recreation / Water
Sports
SPO036000

8.5 in H | 5.5 in W
Status: **ACTIVE**

Related Products

Ebooks

9781738009831

Relative to Wind

On Sailing, Craft, and Community

Phoebe Wang

Key Selling Points

Good crewmates: The editors at Assembly Press have been asking Wang to write a sailing book for over half a decade, and she chose to publish with them rather than going back to multinational because of their commitment to this project.

Focused on Great Lakes sailing, *Relative to Wind* covers recreational sailing and racing in Lake Ontario, including both keelboat and dinghy sailing, and specific aspects of racing like proper gear, safety and communication, starting sequences, crew positions, points of sail, boat terminology, yacht club personalities, communities, culture, racing organizations and volunteer management, regattas, and boat-buying tips.

Offers a cultural study of sailing by addressing related topics like gender equality, decolonization and Indigenization, the history of Maritime painting, literary depictions of the doldrums, and socialization theories. Plus Great Lakes weather and wind conditions, the effects of COVID-19 pandemic, mental health and burnout, working and living in Toronto in the field of education, volunteer labour, and renting and housing precarity.

Fills an important gap: there is a lack of critical and literary creative nonfiction on sailing, particularly by women of colour. Nor are there many works about recreational sports that take an anti-racist, decolonial, and environmental perspective.

Perfect for off-season armchair sailing, kicking back in the cockpit, and for non-sailors too: This is a book filled with the wisdom sailing can impart about ideas of community belonging, writing, and life in general.

Summary

A lingering, long-haul collection of writing about sailing for readers of Julietta Singh and Kyo Maclear.

In *Relative to Wind*, Phoebe Wang delivers a poetic rendering of her decade-long journey of learning to sail and a deep dive into what it means to be a newcomer to an old tradition. From working alongside crewmates in tempestuous conditions to becoming an avid racer and organizer to drafting a wistful love letter to a Wayfarer dinghy—while examining the loose tether between sailing and a creative life—Wang delivers a book for sailors and would-be sailors that is thoughtful and surprising at every tack.

"A thoughtful, illuminating look at life away from land."—*Kirkus*

Contributor Bio

Phoebe Wang is a first-generation Chinese-Canadian who lives and sails in Toronto, Canada. She is the author of the poetry collections *Admission Requirements* (M&S, 2017), shortlisted for the Gerald Lambert Memorial Award, the Pat Lowther Memorial Award, and the Trillium Book Award, and *Waking Occupations* (M&S, 2022), and her fiction and nonfiction have been widely published. She is an adjunct professor and mentor in the University of Toronto Creative Writing MA program.

Quotes

"A thoughtful, illuminating look at life away from land."—*Kirkus*

"A riveting book about our parallel lives, the side passions that steer our hearts and right our balance. I am not a good sailor, have honestly rarely sailed, but I can say without hesitation that you will not find a book that better captures the sport—or the vagaries of wind, collaboration and creative practice. Phoebe Wang's expansive prose is

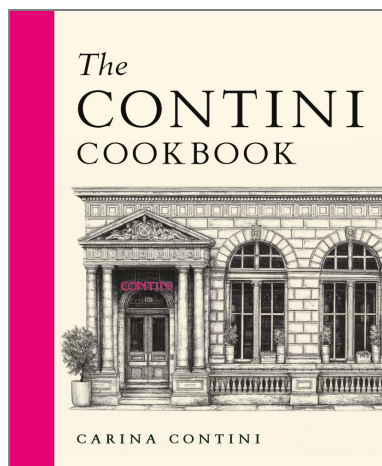

THE CONTINI COOKBOOK

Carina Contini

ISBN 9781780279213

Price £25.00

Publication 07 November 2024 **Format** 246 x 189 mm Hardback

Category Food & Drink

Extent 240 pp

BIC WB, WBA

Rights World All Languages

Illustrations Colour throughout

KEY SELLING POINTS

- Contini, George Street, Edinburgh is one of the few UK restaurants accredited by the Accademia Italiana dell Cucina (The Italian Academy of Cuisine)
- 'The most stylish Italian joint in town' – Peter Irvine, *Scotland the Best*
- Features stunning food photography all taken in the elegant interior of Contini George Street
- Published to celebrate the 20th anniversary of the opening of the restaurant

DESCRIPTION

For Carina Contini food is both a passion and a way of life. Her family's connections to Italy and their extensive travels there – from the rolling hills of Tuscany to the sun-drenched shores of Sicily – have enriched the recipes which feature on the menu of Contini George Street, Edinburgh. At the award-winning restaurant, which Carina runs with her husband, Victor, all the ingredients come direct from Italy or are sourced locally – many even from their own kitchen garden.

In this book Carina shares 100 tried-and-tested dishes for sharing with family and friends including small plates, soups, hearty pastas, meat, seafood dishes, salads, drinks, dolci and other treats. The recipes come from many different parts of Italy, showcasing the rich variety of Italian regional cooking, all of which can be reproduced in your own kitchen.

AUTHOR BIOGRAPHY

After training and working as a chartered surveyor, **Carina Contini** and her husband Victor set up Centotre – now Contini George Street – in Edinburgh. She maintains a high profile in the food and drink industry, having been Glenfiddich Food Personality of the Year and Harpers and Queens Food Personality Scotland. Carina has written on food and drink for *The Scotsman* since 2012 and regularly contributes to *The Herald* and BBC Scotland.

COMPARABLE TITLES

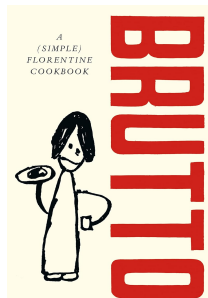

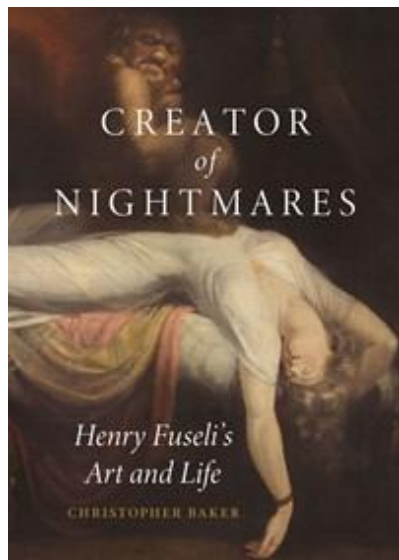

Reaktion Books
9781789149302
Pub Date: 2/02/2025
\$45.00/£30.00 UK
Hardcover

192 Pages
53 color plates, 21 halftones
Art / Individual Artists
ART016030
Sales Restrictions: NSA
Internation Pub Date: 2025-01-02
23.4 cm H | 16.8 cm W | 453.6 g
Wt
Status: **FORTHCOMING**

Creator of Nightmares

Henry Fuseli's Art and Life

Christopher Baker

Summary

A critical biography of the eighteenth-century painter.

Henry Fuseli (1741–1825) was one of the eighteenth century's most provocative and inventive artists. He is best known for his painting *The Nightmare*, which channeled a new form of gothic imagery for the Romantic age. This engaging study of the artist's career unveils Fuseli's complexities, navigating contradictions between literary and painted works, sacred and secular themes, and traditional patronage versus competitive exhibitions. Plotting Fuseli's trajectory from Zurich to Paris, Rome, and ultimately London, *Creator of Nightmares* paints an image of Fuseli as an astute marketer and self-proclaimed genius who transformed himself from a priest to an Enlightenment writer, a mercurial force in the art world, and finally a revered teacher.

Contributor Bio

Christopher Baker is editor of the *Burlington Magazine* and an honorary professor at the University of Edinburgh. He is a former director at the National Galleries of Scotland.

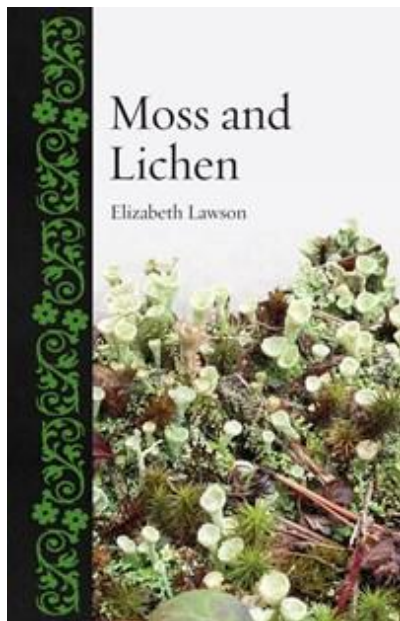

Moss and Lichen

Elizabeth Lawson

Summary

A fascinating guide to the natural and cultural significance of mosses and lichens.

Moss and Lichen is a celebration of the extraordinary biology, beauty, and resilience of two unassuming organisms. Endowed with unique abilities to thrive in extreme habitats, mosses and lichens defy easy categorization. Mosses, which are integral to the plant kingdom, and lichens, which are a kingdom unto themselves, colonize a variety of landscapes from rainforests to deserts to urban streets. Long neglected for lacking flowers, these organisms are now beloved for their significant role in maintaining the health of our world's ecosystem.

Elizabeth Lawson describes how mosses and lichens shape landscapes, prevent erosion, and sequester carbon, but she also offers a wide-ranging introduction to the biologists, artists, and writers inspired by their beauty. *Moss and Lichen* will inspire a newfound appreciation for these unsung heroes of the natural world.

Contributor Bio

Elizabeth Lawson is a naturalist, writer, and former president of the American Primrose Society. Her books include *Primrose*, also in Reaktion Books' Botanical series.

Reaktion Books
9781789149395
Pub Date: 18/02/2025
\$27.00/£18.00 UK
Hardcover

256 Pages
96 color plates, 17 halftones
Nature / Plants
NAT026000
Series: Botanical
Sales Restrictions: NSA
Internation Pub Date: 2025-01-11
21.6 cm H | 13.8 cm W | 453.6 g
Wt
Status: **FORTHCOMING**

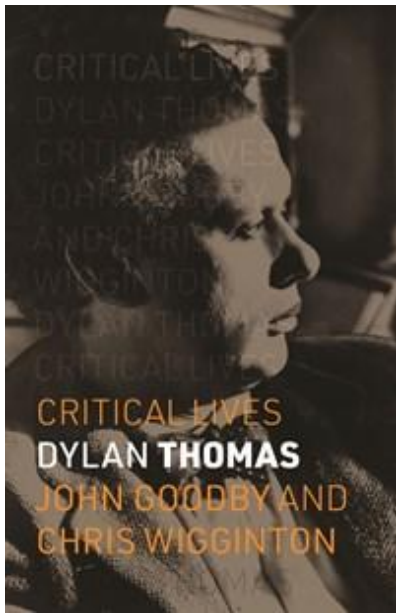

Dylan Thomas

John Goodby, Chris Wigginton

Summary

An accessible introduction to the life and work of the inventive Welsh poet.

Dylan Thomas—author of some of the century’s greatest poetry, stories, and film scripts as well as one of the greatest radio features ever broadcast, *Under Milk Wood*—is often characterized as self-indulgent. This concise and up-to-date biography challenges this depiction with a fresh portrait of the artist as a consummate professional. John Goodby and Chris Wigginton locate the source of Thomas’s daring and inventive style in the poet’s Anglo-Welsh origins as well as his historical, cultural, and social contexts: the Great Depression and 1930s literary London, surrealism, World War II, and Cold War popular culture. The result is a revealing and fresh introduction to the life and work of this important Welsh writer.

Contributor Bio

John Goodby is professor of arts and culture at Sheffield Hallam University. The leading authority on Dylan Thomas, he has written extensively on his work and edited his *Collected Poems*.

Chris Wigginton is pro vice-chancellor of Sheffield Hallam University. His books include *Modernism from the Margins: The 1930’s Poetry of Louis MacNeice and Dylan Thomas*.

Reaktion Books
9781789149326
Pub Date: 9/12/2024
\$22.00/£12.99 UK
Paperback

240 Pages
30 halftones
Biography & Autobiography
BIO000000
Series: Critical Lives
Sales Restrictions: NSA
Internation Pub Date: 2024-12-13
20 cm H | 13 cm W | 453.6 g Wt
Status: **FORTHCOMING**

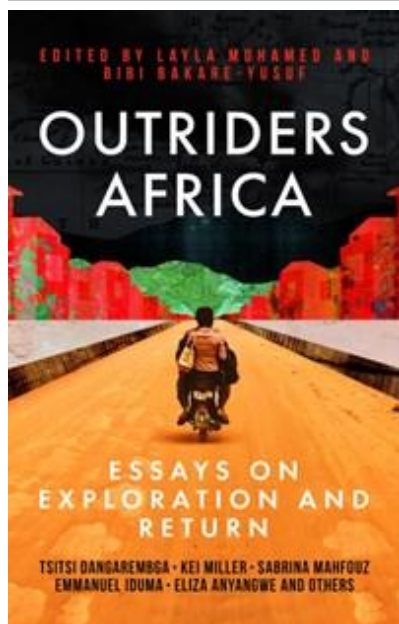

Cassava Republic Press
9781913175238
1913175235
Pub Date: 11/12/2024
On Sale Date: 11/12/2024
\$20.95/\$22.99 Can./£14.99
UK/€14.99 EU
Discount Code: HC
Hardcover with printed dust jacket

Carton Qty: 20
Travel / Africa
TRV002000

5.3 in H | 8.5 in W
Status: **FORTHCOMING**

Outriders Africa

Essays on Exploration and Return

Layla Mohamed, Bibi Bakare-Yusuf, Kei Miller, Wanjiru Koinange, Amanda Thomson, Tsitsi Dangarembga, Eliza Anyangwe, Kayus Bankole, Donna Obaseki-Ogunnaike, Sabrina Mahfouz

Key Selling Points

Outriders Africa chronicles journeys from across the continent, with 10 writers travelling in pairs, and each documenting the experience through a personal lens. The collection features a mix of essays, poetry, letters and travel diaries.

All the writers are of African heritage which informs their experiences, and decolonises the travel-writing genre by exploring the continent through the African Gaze.

Covers themes of migration and return, colonialism and tourism, sensuality and womanhood, loss and recovery.

Donna Ogunnaike and Wanjru Koinange examine cultures of dating and sensuality in The Gambia, Rwanda and Senegal.

Tsitsi Dangarembga and Nadine Aisha Jassat Cape Town journey unlocks family histories.

Emmanuel Iduma and Eliza Anyangwe visit the beaches of Madagascar and Comoros, and talk politics, migration and tourism with their guide Hamidou.

Amanda Thomson and Sabrina Mahfouz explore the flora and fauna of Cape Town, and the role of 'renaming' in South Africa's colonial legacy.

Kei Miller and Kayus Bankole travel East to West, from Ethiopia's Rastafarian communities, to a Ghanaian castle whose history is inextricably tied to slavery.

A collection of essays, poetry, letters and travel diaries, chronicling 10 writers' journeys across Africa.

Summary

It is Spring 2020, and 10 writers of African heritage, travelling in pairs, set out on journeys across Africa. It is a strange time to be travelling, and the shifting state of the world is reflected in temperature checks at borders, hand sanitiser outside churches, and truncated journeys.

Against this backdrop, their travels take them from the tourist beaches of Madagascar and Comoros to the Rastafarian town of Shashamane in Ethiopia, and from questions of renaming amongst the flora and fauna of Cape Town to learning to walk in circles and embrace sensuality in The Gambia.

Through essays, travel diaries, letters and poetry, *Outriders Africa* is an evocative and enthralling exploration of forgotten family histories, reckoning with grief (both personal and historical), and what it truly means to return.

Contributor Bio

Layla Mohamed is an assistant editor at Cassava Republic Press. She studied Law at Oxford University, has been a panellist at Africa Writes and edited *A Small Silence* by Jumoke Verissimo, which was shortlisted for the RSL Ondaatje Prize 2020. She has written about race and colonialism on online platforms.

Sabrina Mahfouz is a Fellow of The Royal Society of Literature and has won a Sky Arts Academy Award for Poetry, the Westminster Prize for New Playwrights and a Fringe First Award for her play *Chef*.

Nadine Aisha Jassat's writing has appeared in *It's Not About the Burqa* (Picador) and *404 Ink's* highly-praised *Nasty Women*. She won a Scottish Book Trust New Writers' Award for Fiction and the prestigious Edwin Morgan Poetry Award.

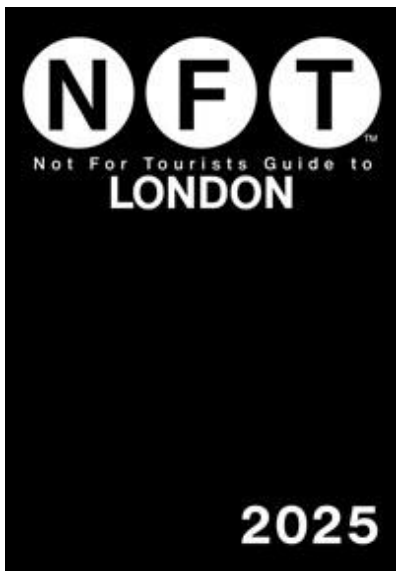

Not For Tourists
9781510781092
Pub Date: 5/11/2024
\$19.99/\$26.99 Can./£14.99 UK
Trade Paperback

640 Pages
Color illustrations throughout
Carton Qty: 36
Travel / Europe
TRV009070
Series: Not For Tourists
14.6 cm H | 10.2 cm W | 2.8 cm T
| 362.9 g Wt
Status: **ACTIVE**

Not For Tourists Guide to London 2025

Not For Tourists

Summary

With details on everything from Big Ben to Brick Lane, this is the only guide a native or traveler needs.

Whether you've called London your home for decades or just arrived last night, there's information in the *Not For Tourists Guide to London* that you need to know. This map-based, neighborhood-by-neighborhood guide will help you master this amazing city like an expert. Packed with more than 150 maps and thousands of listings for restaurants, shops, theaters, and under-the-radar spots, you won't find a better guide to London.

Want to score tickets to a big Arsenal or Chelsea football match? NFT has you covered. How about royal sightseeing at Buckingham Palace? We've got that, too. The best Indian restaurant, theater experience, bookstore, or cultural site—whatever you need—NFT puts it at your fingertips. This light and portable guide also features:

- An invaluable street index
- Profiles of more than one hundred neighborhoods
- Listings for museums, landmarks, the best shopping, and more

You don't need to be Sherlock Holmes to solve the mysteries of London; NFT has all the answers!

Contributor Bio

Not For Tourists (NFT) released their first book, a guide to Manhattan, in May of 2000. Today, NFT is an urban lifestyle brand that works closely with city and neighborhood editors in Boston, Chicago, London, Los Angeles, and New York. Their offices are in New York City.

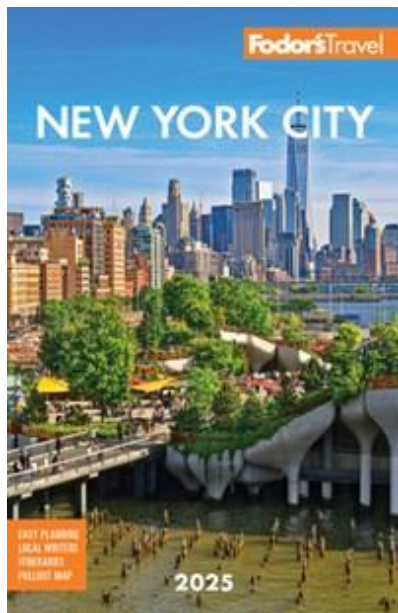

Fodor's New York City 2025

Fodor's Travel Guides

Key Selling Points

COMPETITIVE ADVANTAGE:

- Local NYC-based writers who know the city like the back of their hands
- *Pull-out map and numerous "best of" lists with color photos*
- Updated annually

TOURISM TRENDS:

- NYC Tourism + Conventions, the city's tourism bureau, predicts that in 2024 the city is expected to exceed its prior 2019 record of 66.6 million visitors with an anticipated 69.3 million visitors
- Major infrastructure projects expected in the next year include Bronx Point, a mixed-used development in the South Bronx with housing, retail, and cultural attractions including the Universal Hip Hop Museum (2024); Hudson River Park's Pier 97 on West 57th Street, which will have a river-facing lawn area for concerts and performances, food concessions, and a playground (2024)

FULLY REDESIGNED!

- **New front cover** has eye-catching full-bleed images with key selling points on the front
- **New back cover** is fully-redesigned
- **"Best of" Lists** will visually engage the reader and provide an overview of the entire destination (best things to eat, see, do, drink, as well as what to read and watch before going)
- **Visually focused with more color and images** including more full and half-page images throughout and color-coded category icons
- **Other useful features** including Things You Need to Know, Great Itineraries, Walking Tours, and a Calendar of Events
- **"Travel Smart"** (logistical planning tips section) now at the front of the book and redesigned to be more infographic in feel
- **Stronger Voice and Opinions** give all Fodor's guides more personality. Books are more friendly and conversational in tone, going beyond informational to being inspirational

CURATED AND RELEVANT:

- **Focused coverage** on only the best places so travelers can make the most out of their limited time.
- **Carefully vetted recommendations** for all types of establishments and price points.

CONCISE:

- **Shortened reviews** presented with brevity and focus.

Please see additional key selling points in the book main description

Summary

Whether you want to explore the High Line, see a Broadway show, or grab a slice of pizza in Brooklyn, the local Fodor's travel experts in New York City are here to help! *Fodor's New York City 2025* guidebook is packed with maps, carefully curated recommendations, and everything else you need to simplify your trip-planning process and make the most of your time. This new edition has been **fully-redesigned** with an easy-to-read layout, fresh information, and beautiful color photos.

Fodor's New York City 2025 travel guide includes:

Fodor's Travel
9781640977358
164097735X
Pub Date: 11/5/2024
On Sale Date: 11/5/2024
\$21.99/\$28.99 Can./£15.99
UK/€19.99 EU
Discount Code: TP
Trade Paperback

512 Pages
Carton Qty: 24
Travel / United States
TRV025050
Series: Full-color Travel Guide
8 in H | 5.2 in W
Status: **FORTHCOMING**

Related Products

Also Available

Fodor's New York City 2024
9781640976443 \$21.99

Ebooks

9781640977631

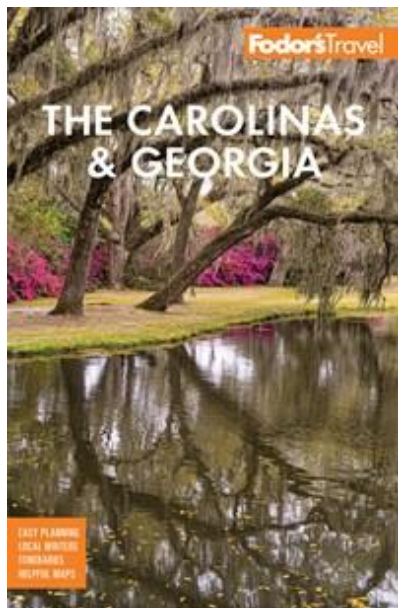

Fodor's Travel
9781640977044
164097704X
Pub Date: 11/12/2024
On Sale Date: 11/12/2024
\$22.99/\$29.99 Can./£16.99
UK/€20.99 EU
Discount Code: TP
Trade Paperback

608 Pages
Carton Qty: 28
Travel / United States
TRV025090
Series: Full-color Travel Guide
8 in H | 5.2 in W
Status: **FORTHCOMING**

Related Products

Also Available

Fodor's The Carolinas & Georgia
9781640974128 \$19.99

Ebooks

9781640977556

Fodor's Carolinas & Georgia (25th Edition)

Fodor's Travel Guides

Key Selling Points

COMPETITIVE ADVANTAGE:

- One of the most current books on the Carolinas and Georgia from any major guidebook company
- The most comprehensive selection of hotel and restaurant reviews
- In-depth information on the important nuts and bolts about traveling in and around the Carolinas and Georgia (which includes Charleston, Savannah, and Asheville)
- Expertly researched features on must-visit attractions, as well as fun, color-photo features such as 25 Ultimate Experiences
- New coverage of Congaree National Park

TOURISM TRENDS:

- The hotel sector has seen substantial growth with the recent opening of Four Points Sheridan Atlanta Downtown and the Palmetto in Charleston, and coming in 2024 are the Dream Hotel Atlanta and Signia by Hilton Atlanta and the Moxy Charlotte.
- Other developments: in Atlanta, the Centennial Yards complex will feature residential, retail shops, restaurants and boutique hotels; Charleston saw the 2023 opening of the International African American Museum. In 2024 Savannah's newly expanded Convention Center makes its anticipated debut.
- Asheville, NC will host the Adventure Travel Trade Association's AdventureElevate conference, and the Charlotte Douglas International Airport in Charlotte will unveil new features in 2024, including a scenic overlook.

FULLY REDESIGNED!

- **New front cover** has eye-catching full-bleed images with key selling points on the front
- **New back cover** is fully-redesigned
- **"Best of" Lists** will visually engage the reader and provide an overview of the entire destination (best things to eat, see, do, and drink)
- **Visually focused with more color and images** including more full and half-page images throughout and color-coded category icons
- **Other useful features** including What to Watch and Read and On the Calendar
- **"Travel Smart"** (logistical planning tips section) now at the front of the book and redesigned to be more infographic in feel
- **Stronger Voice and Opinions** give all Fodor's guides more personality. Books are more friendly and conversational in tone, going beyond informational to being inspirational

CURATED AND RELEVANT:

- **Focused coverage** on only the best places so travelers can make the most out of their limited time.
- **Carefully vetted recommendations** for all types of establishments and price points.

CONCISE:

- **Shortened reviews** presented with brevity and focus.

Please see additional key selling points in the book main description

Summary

Whether you want to drive a scenic road in Great Smoky Mountains National

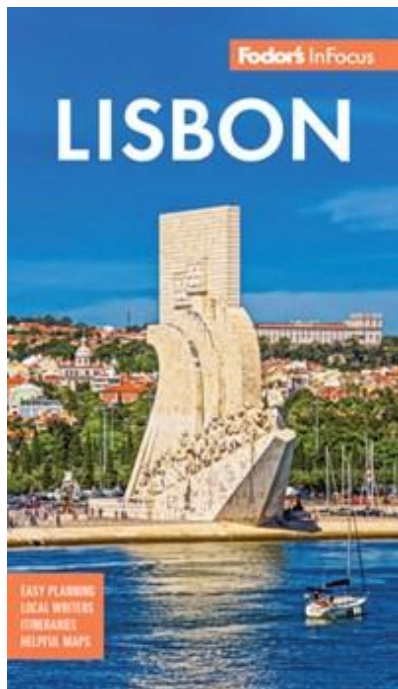

Fodor's InFocus Lisbon

Fodor's Travel Guides

Key Selling Points

COMPETITIVE ADVANTAGE:

- Only Lisbon-focused guide to also include Sintra, Estoril, Cascais, and Guincho, all common day trips.

TOURISM TRENDS:

- In 2022 Lisbon saw 5.4 million overnight visitors, essentially a full recovery of pre-pandemic tourism. Lisbon, and Portugal generally, have seen a major increase in tourism over the past decade, becoming known as a European tourism hotspot at a much lower pricetag than other western European countries.

FULLY REDESIGNED!

- **New front cover** has eye-catching full-bleed images with key selling points on the front
- **New back cover** is fully-redesigned
- **"Best of" Lists** will visually engage the reader and provide an overview of the entire destination (best things to eat, see, do, drink, as well as what to read and watch before going)
- **Visually focused with more color and images** including more full and half-page images throughout and color-coded category icons
- **Other useful features** including Great Itineraries and Calendar of Events,
- **"Travel Smart"** (logistical planning tips section) now at the front of the book and redesigned to be more infographic in feel
- **Stronger Voice and Opinions** give all Fodor's guides more personality. Books are more friendly and conversational in tone, going beyond informational to being inspirational

CURATED AND RELEVANT:

- **Focused coverage** on only the best places so travelers can make the most out of their limited time.
- **Carefully vetted recommendations** for all types of establishments and price points.

CONCISE:

- **Shortened reviews** presented with brevity and focus.

Please see additional key selling points in the book main description

Summary

Whether you want to explore Belém Tower, sample pastel de nata, or be swept away by a Fado performance, the local Fodor's travel experts in Lisbon are here to help! *Fodor's InFocus Lisbon* guidebook is packed with maps, carefully curated recommendations, and everything else you need to simplify your trip-planning process and make the most of your time.

This brand-new title has been designed with an easy-to-read layout, fresh information, and beautiful color photos.

Fodor's InFocus Lisbon travel guide includes:

- **AN ILLUSTRATED ULTIMATE EXPERIENCES GUIDE** to the top things to see and do
- **MULTIPLE ITINERARIES** to effectively organize your days and maximize your

Fodor's Travel
9781640977365
1640977368
Pub Date: 11/12/2024
On Sale Date: 11/12/2024
\$14.99/\$19.99 Can./£10.99
UK/€13.99 EU
Discount Code: TP
Trade Paperback

288 Pages
Carton Qty: 64
Travel / Europe
TRV009130
Series: Full-color Travel Guide
7.4 in H | 4.3 in W
Status: **FORTHCOMING**

Related Products

Ebooks

9781640977648



Frommer's Rome, Florence and Venice 2025 (10th Edition)

Elizabeth Heath, Donald Strachan, Stephen Keeling

Summary

There is no better introduction to Italy than the classic itinerary of Rome, Florence and Venice. But it is not dummy-proof, which is why we enlisted three of Italy's most knowledgeable experts to pen this guide. Their helpful advice, and honest, opinionated recommendations will allow you to find the hidden gems that other visitors miss, avoid crowds and lines, and, most importantly: plan the vacation of a lifetime.

Frommer's Rome, Florence and Venice includes:

- Tons of useful maps, including a detachable fold-out map
- Detailed itineraries to help you make the most of your time while avoiding the crowds and lines
- Restaurant choices that take you to the places Italians love—and tourists usually miss
- Rewarding day trips to fascinating destinations such as Pompeii, Verona, and the Tuscan hill towns
- Candid reviews, with star ratings, of the best places to eat, shop, stay, and sample the nightlife in each city, in all price ranges. Plus a look at which places you can skip!
- Accurate, up-to-date info on prices, transportation, addresses, and everything else you will need to plan your trip
- A chapter of useful phrases including a pronunciation guide
- Smart advice for how to save money on airfare to Italy, on hotels and on attractions

About Frommer's:

There's a reason that Frommer's has been the most trusted name in travel for more than 65 years. Arthur Frommer created the best-selling guide series in 1957 to help American servicemen fulfill their dreams of travel in Europe, and since then, we have published thousands of titles because a household name helping millions upon millions of people realize their own dreams of seeing our planet. Travel is easy with Frommer's.

Contributor Bio

Links

- <https://www.frommers.com/>

FrommerMedia
9781628876093
1628876093
Pub Date: 11/5/2024
On Sale Date: 11/5/2024
\$22.95/\$29.99 Can./£16.99
UK/€20.99 EU
Discount Code: TP
Trade Paperback

378 Pages
color photos, maps, charts,
throughout
Carton Qty: 40
Travel / Europe
TRV009110
Series: Complete Guide

8 in H | 5 in W
Status: **FORTHCOMING**

Related Products

Also Available

Frommer's Rome, Florence and
Venice 2024 9781628875836
\$22.95

Ebooks

9781628876109

Comp Titles

Frommer's Rome, Florence and Venice 2024	Strachan Donald	FrommerMedia 11/7/2023	9781628875836 1628875836	\$22.95 USD	Trade Paperback	Travel
---	--------------------	------------------------	-----------------------------	----------------	--------------------	--------

No sales or inventory history loaded for this account. If you think there should be or would like to learn how to load this data, [Click here](#).

Subrights

No subrights have been specified.

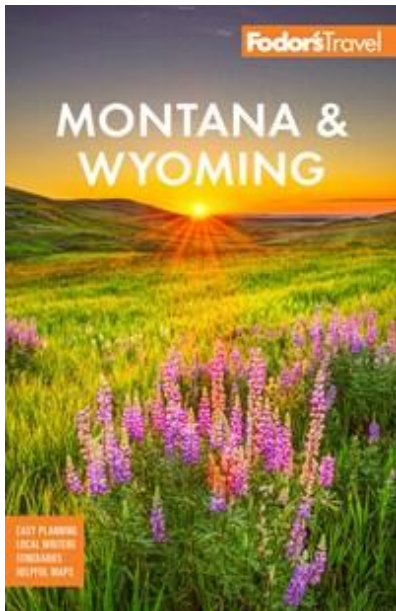

Fodor's Montana & Wyoming (6th Edition)

with Yellowstone, Grand Teton, and Glacier National Parks

Fodor's Travel Guides

Key Selling Points

COMPETITIVE ADVANTAGE:

- The most up-to-date coverage of Montana & Wyoming available in print.

TOURISM TRENDS:

- Yellowstone National Park is the most popular destination for tourists in Montana & Wyoming; although visitation was slightly off the record highs of 2022, the number of visitors in 2023 remains 12% above where it was in 2019, according to the National Park Service.
- Summer visitors to Glacier National Park were 1.2% more than in 2022.

FULLY REDESIGNED!

- **New front cover** has eye-catching full-bleed images with key selling points on the front
- **New back cover** is fully-redesigned
- **"Best of" Lists** will visually engage the reader and provide an overview of the entire destination (best things to eat, see, do, drink, as well as what to read and watch before going)
- **Visually focused with more color and images** including more full and half-page images throughout and color-coded category icons
- **Other useful features** including Great Itineraries, Calendar of Events, Best Family-Friendly Destinations
- **"Travel Smart"** (logistical planning tips section) now at the front of the book and redesigned to be more infographic in feel
- **Stronger Voice and Opinions** give all Fodor's guides more personality. Books are more friendly and conversational in tone, going beyond informational to being inspirational

CURATED AND RELEVANT:

- **Focused coverage** on only the best places so travelers can make the most out of their limited time.
- **Carefully vetted recommendations** for all types of establishments and price points.

CONCISE:

- **Shortened reviews** presented with brevity and focus.

Please see additional key selling points in the book main description

Summary

Whether you want to explore what remains of the Old West, visit Yellowstone National Park, or find your bliss at a guest ranch or in a Jackson Hole ski resort, the local Fodor's travel experts in Montana and Wyoming are here to help! *Fodor's Montana & Wyoming* guidebook is packed with maps, carefully curated recommendations, and everything else you need to simplify your trip-planning process and make the most of your time.

Fodor's Montana & Wyoming travel guide includes:

- **AN ILLUSTRATED ULTIMATE EXPERIENCES GUIDE** to the top things to see and do
- **MULTIPLE ITINERARIES** to effectively organize your days and maximize your



Fodor's Travel
 9781640977020
 1640977023
 Pub Date: 10/22/2024
 On Sale Date: 10/22/2024
 \$22.99/\$29.99 Can./£16.99
 UK/€20.99 EU
 Discount Code: TP
 Trade Paperback

464 Pages
 Carton Qty: 24
 Travel / United States
 TRV025120
 Series: Full-color Travel Guide
 8 in H | 5.2 in W
 Status: **ACTIVE**

Related Products

Previous Editions

Fodor's Montana and Wyoming
 9781640974524 \$19.99

Ebooks

9781640977525

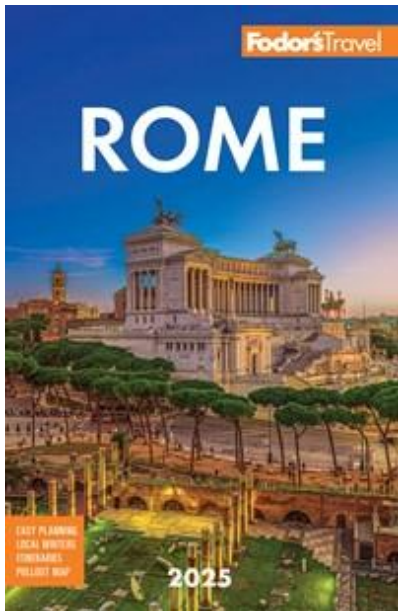

Fodor's Rome 2025 (15th Edition)

Fodor's Travel Guides

Key Selling Points

COMPETITIVE ADVANTAGE:

- Updated annually.

TOURISM TRENDS:

- According to [TourismReview](#), which takes its data from the Lazio Bilateral Tourism Authority, there were 5,821,362 international tourist arrivals in Rome in 2022, a 500% Increase From 2021. The arrivals of domestic tourists to Rome had an increase of 110.15% on 2021 and a recovery of 81.94% on 2019.

FULLY REDESIGNED!

- **New front cover** has eye-catching full-bleed images with key selling points on the front
- **New back cover** is fully-redesigned
- **"Best of" Lists** will visually engage the reader and provide an overview of the entire destination (best things to eat, see, do, drink, as well as what to read and watch before going)
- **Visually focused with more color and images** including more full and half-page images throughout and color-coded category icons
- **Other useful features** including Great Itineraries, Walking Tours, Calendar of Events, "Rome with Kids," and "Rome Today."
- **"Travel Smart"** (logistical planning tips section) now at the front of the book and redesigned to be more infographic in feel
- **Stronger Voice and Opinions** give all Fodor's guides more personality. Books are more friendly and conversational in tone, going beyond informational to being inspirational

CURATED AND RELEVANT:

- **Focused coverage** on only the best places so travelers can make the most out of their limited time.
- **Carefully vetted recommendations** for all types of establishments and price points.

CONCISE:

- **Shortened reviews** presented with brevity and focus.

Please see additional key selling points in the book main description

Summary

Whether you want to tour the Roman Forum, explore the Vatican, or marvel at the Colosseum, the local Fodor's travel experts in Rome are here to help! Fodor's Rome guidebook is packed with maps, carefully curated recommendations, and everything else you need to simplify your trip-planning process and make the most of your time. This new edition has been **fully updated** with an easy-to-read layout, fresh information, and beautiful color photos.

Fodor's Rome travel guide includes:

- **AN ILLUSTRATED ULTIMATE EXPERIENCES GUIDE** to the top things to see and do
- **MULTIPLE ITINERARIES** to effectively organize your days and maximize your time

Fodor's Travel
 9781640977105
 1640977104
 Pub Date: 10/29/2024
 On Sale Date: 10/29/2024
 \$22.99/\$29.99 Can./£16.99
 UK/€20.99 EU
 Discount Code: TP
 Trade Paperback

320 Pages
 Carton Qty: 40
 Travel / Europe
 TRV009110
 Series: Full-color Travel Guide
 8 in H | 5.2 in W
 Status: **FORTHCOMING**

<p>Related Products</p> <p>Previous Editions Fodor's Rome 2024 9781640976320 \$22.99</p> <p>Ebooks 9781640977624</p>
--



Frommer's Italy 2025 (17th Edition)

Elizabeth Heath, Donald Strachan, Stephen Brewer, Stephen Keeling, Michelle Schoenung

Summary

Frommer's books aren't written by committee, by A.I., or by travel writers who simply pop in briefly to a destination and then consider the job done. We use seasoned, locally-based journalists like Elizabeth Heath, Donald Strachan, and Michelle Schoenung, plus long-time Italy experts Stephen Brewer and Stephen Keeling to research our guides. They've checked out all of Italy's best hotels, attractions, shops, wineries, and restaurants in person, and offer authoritative, candid reviews that will help you find the venues that suit your tastes and budget, whether you're a backpacker or on a romantic honeymoon.

Most importantly, none of these journalists are shy about telling you what you should see...and what you can skip without regret.

With helpful advice and honest recommendations from Frommer's expert authors, you'll walk among the ancient ruins of Pompeii, float along the canals of Venice, appreciate Renaissance masterworks in Florence, explore off-the-beaten-path Puglia and live la dolce vita in Rome—as well as discover timeless wonders such as the vineyards of Tuscany and cliff-top towns perched along the Amalfi Coast and the Cinque Terre.

Inside the guide:

- Full-color photos and helpful maps throughout, including a detachable foldout map
- 6 Detailed itineraries for planning your trip to suit your schedule and interests (and help you avoid lines and crowds)
- Compelling cultural information so that you'll better understand the history, cuisine, and traditions of Italy
- Candid reviews of the best restaurants, historic sights, museums, tours, shops, and experiences—and no-punches-pulled info on the ones not worth your time and money. We also include star ratings, so you can scan the text quickly and see which options are most appealing.
- Accurate, up-to-date info on transportation, useful websites, telephone numbers, health care options and more
- Budget-planning help with exact pricing listed, so there's never any guessing, along with ways to save money, whether you're traveling on a shoestring or in the lap of luxury
- Helpful planning advice for getting to Italy, getting around, getting the best price on lodgings and attractions

FrommerMedia
9781628876055
1628876050
Pub Date: 10/22/2024
On Sale Date: 10/22/2024
\$27.95/\$36.99 Can./£19.99
UK/€24.99 EU
Discount Code: TP
Trade Paperback

858 Pages
color photos throughout
Carton Qty: 16
Travel / Europe
TRV009110
Series: Complete Guide
8 in H | 5 in W
Status: **FORTHCOMING**

Related Products

Previous Editions

Frommer's Italy 2024
9781628875638 \$27.95

Ebooks

9781628876062

About Frommer's: There's a reason Frommer's has been the most trusted name in travel for more than 65 years. Arthur Frommer created the best-selling guide series in 1957 to help American servicemen fulfill their dreams of travel in Europe, and since then, we have published thousands of titles, become a household name, and helped millions upon millions of people realize their own dreams of seeing our planet. Travel is easy with Frommer's.



Frommer's Washington D.C. (10th Edition)

Meredith Pratt

Summary

Washington, D.C. can be an overwhelming destination for visitors. With so many museums, so many historic sights, so many working government buildings to see—not to mention its scintillating foodie and nightlife scenes—just coming up with a plan can be stressful.

That's where Frommer's comes in. We've hired an expert local journalist to supply the advice and details you need to create the right vacation for you. These include strategies for seeing the iconic sights without fighting the crowds; places that only locals know about; and smart itineraries so you can make the most of your time in the city.

Frommer's Washington, D.C. includes:

- Dozens of maps, including a handy fold-out map of the city and its underground train system to help you make the most efficient (and fun) use of your time in the Capitol
- Exact pricing for hotels, attractions, restaurants and more so there's never any guessing
- Public transportation information for every listing in the book, so you don't have to waste money on pricey rides
- Opinionated reviews which tell you which attractions are worth your time, and which will only be of interest to some visitors
- Star ratings that take value into account, and will help you find the right hotels, restaurants, nightspots and shops for you, in all price ranges
- Fun-to-follow, self-guided walking tours of DC's most intriguing neighborhoods
- Vibrant photographs throughout
- Helpful planning advice for getting there, getting around, getting the best price on lodgings, and getting the most from your trip

About Frommer's: There's a reason that Frommer's has been the most trusted name in travel for more than 60 years. Arthur Frommer created the bestselling guide series in 1957 to help American service members fulfill their dreams of travel in Europe. Since then, we have published thousands of titles, becoming a household name by helping millions upon millions of people realize their own dreams of seeing our planet. Travel is easy with Frommer's.

Contributor Bio

Meredith Pratt is a Baltimore native and a Washingtonian for more than 10 years. She is an avid traveler, writer and art lover. Her work has profiled international travel locales, high-powered personalities, and top D.C. destinations. Pratt's writing has appeared in *USA Today*, *Executive Travel*, *Baltimore Magazine*, *Web MD*, *the Magazine*, *Washington Flyer*, and many others. This will be her third time as author of this guidebook.

In addition to writing, Meredith also has a strong background in media relations, brand development, event planning, and social media for travel clients. She most recently worked to promote Maryland's national tourism. Meredith resides in the suburbs outside of Washington, D.C. area with her husband, daughter, and several four-legged family

FrommerMedia
9781628876154
1628876158
Pub Date: 10/22/2024
On Sale Date: 10/22/2024
\$22.95/\$29.99 Can./£16.99
UK/€20.99 EU
Discount Code: TP
Trade Paperback

378 Pages
color photos throughout
Carton Qty: 40
Travel / United States
TRV025090
Series: Complete Guide
8 in H | 5 in W
Status: **FORTHCOMING**

Related Products

Previous Editions

Frommer's Washington, D.C.
2024 9781628875874 \$22.95

Ebooks

9781628876161

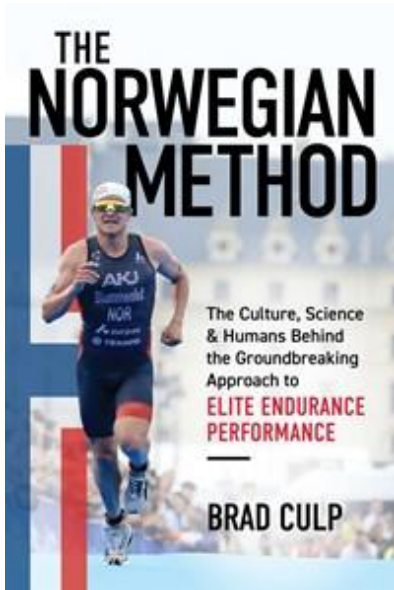

80/20 Publishing
 9798989256969
 9798989256969
 Pub Date: 10/22/2024
 \$21.95/\$29.95 Can.
 Trade Paperback

256 Pages
 infographics
 Carton Qty: 40
 Sports & Recreation / Training
 SPO047000

9 in H | 6 in W | 0.7 in T | 0.9 lb
 Wt

Status: **FORTHCOMING**

Norwegian Method

The Culture, Science, and Humans Behind the Groundbreaking Approach to Elite Endurance Performance

Brad Culp

Summary

Find out how a sparsely-populated country came to dominate the world of endurance sports and get a blueprint for high performance.

Norway has long stacked the field with champions in sports like Nordic skiing and sailing, but a new generation of athletes has arrived on the endurance scene, smashing records and grabbing medals in running, cycling, and triathlon.

Sports journalist Brad Culp unpacks the rise of the Norwegian method and its meticulous scientific protocols, which upend long-held beliefs about training and performance.

With its rugged terrain and harsh weather, Norway has a way of hardening competitors for any test. Culp explores the how the Scandinavian culture imbues a unique biopsychosocial approach to performance. He also introduces the athletes, coaches, and scientists who are shaking up the world of endurance sports. Their secret? Plenty of volume at low intensity, punctuated with hard-fought double-threshold workouts, which seems to turn workhorses into winners—they know when to hold back and when to go all-out.

The Norwegian Method is a real-life story of how discipline and determination can be employed to overcome seemingly impossible odds and achieve breakthrough performances. Culp gives endurance athletes a blueprint of how to adapt their training to look more like that of Norway's Jakob Ingebrigtsen and Kristian Blummenfelt.

Contributor Bio

Brad Culp is a sports journalist, former Editor-in-Chief of Triathlete Magazine, Media Manager of the International Triathlon Union, and LAVA magazine, the official publication of the IRONMAN triathlon series.

Culp is also an accomplished athlete. He won three state titles in high school water polo and earned All-American honors in swimming as part of a relay team. Culp finished his first Ironman triathlon during his junior year of college, where he was the youngest athlete competing at Ironman Wisconsin at age 19. He also founded the high-performing Miami University Triathlon Club and continues to compete at a high level in endurance sports.

Culp is a contributor to the *Red Bull Red Bulletin*, *Men's Journal*, *220 Triathlon*, *Triathlon Lumina*, *Triathlon Plus*, and *Slowtwitch*. He lives in Geneva, Illinois with his wife and two children.

Marketing Plans

- Promotional marketing campaign includes email blasts, publicity, paid social media advertising.
- Advance galley publicity campaign to 30 key media that cover Olympic sports.
- Author publicity campaign in the lead-up to the 2024 Summer Olympics and 2024 Ironman World Championships including interview consideration on NBC, New York Times, Sports Illustrated, The Athletic
- Publicity outreach to key endurance sports training media including Triathlete, Bicycling, Dr. Stephen Seiler YouTube channel, The Norwegian Method Podcast, 80/20 Endurance, Fast Talk Podcast, TrainerRoad, Triathlon Science, and more.



Adorable Home Coloring Book

A Kawaii Collection of Cute and Creative Tiny Homes (Coloring Book for Adults)

Thanh Nguyen

Summary

Embark on a journey of imagination and tranquility with this cute and unique coloring book filled with drawings of whimsical homes, quaint coffee shops, and dream-worthy bookstores!

The pages within the *Adorable Home Coloring Book* will walk you through a journey of wonder and nostalgia. It acts as a return to the sweet dreams and wild creative days we all had as children. Each page strikes a perfect balance between easy-to-color spaces and charming details, ensuring that the process is neither overwhelming nor monotonous, yet remains truly enchanting.

This kawaii coloring book for adults is otherworldly and utilizes fantastical elements mixed in with mundane items, making it a truly special experience. The book acts as a link between generations as it is the perfect activity for everyone to enjoy and share. The coloring book is a celebration of imagination, a tribute to the child within us all, yearning for a world of peace, simplicity, and adorable wonders.

Contributor Bio

Thanh Nguyen, artistically known as Bakemono, from UniQ Studio in Hanoi, Vietnam, is an accomplished artist and comic book author renowned for his unique blend of abstract art. His work, celebrated for its vivid imagination and captivating storytelling, has earned him acclaim in the realm of children's comics.

Illustrations

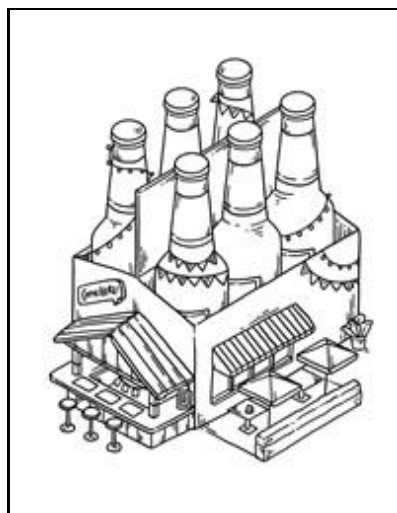
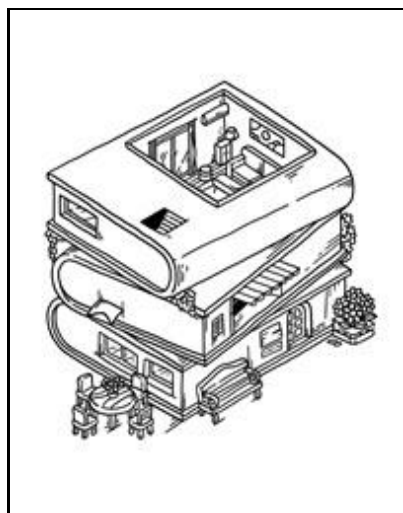

Ulysses Press
9781646047499
1646047494
Pub Date: 11/5/2024
\$14.95/\$19.95 Can./£16.99 UK
Trade Paperback

88 Pages
40 black and white illustrations
Carton Qty: 54
Games & Activities / Coloring
Books
GAM019000

9 in H | 7 in W
Status: **ACTIVE**

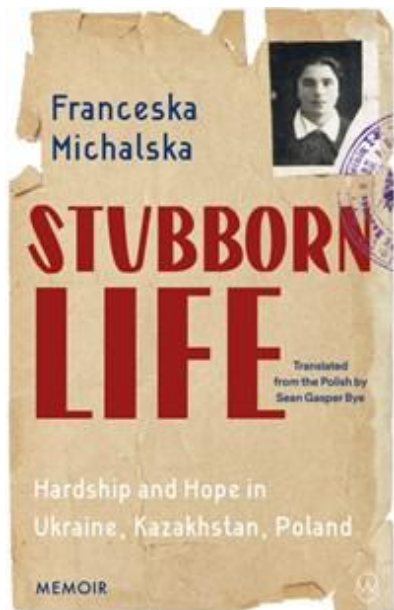

World Editions
9781642861525
1642861529
Pub Date: 11/5/2024
On Sale Date: 11/5/2024
\$19.99/\$25.99 Can./£17.99
UK/€17.99 EU
Discount Code: TP
Trade Paperback

200 Pages
B&W
Carton Qty: 36
Biography & Autobiography
/ Memoirs
BIO026000

8 in H | 5 in W
Status: **FORTHCOMING**

Stubborn Life

Hardship and Hope in Ukraine, Kazakhstan, Poland

Franceska Michalska, Sean Gasper Bye

Key Selling Points

- The current war in Ukraine gives this story a renewed urgency and relevance for our current time
- Will appeal to a very wide audience, all those interested in Ukraine, history, medical biography, inspiring stories of female empowerment, of resilience, of feminism, of life-affirming true stories of human strength and endurance
- Franceska Michalska was born in 1923 in Kamieniec Podolski, Ukraine. This is her memoir of surviving the great famine of 1931–32 before falling victim to growing Stalinist terror and the mass deportation of Poles from the region to Kazakhstan. After walking for 8,000 km and suffering unspeakable hardships, she finally arrives in Poland and becomes a doctor
- Writing in a heartfelt yet matter-of-fact style, Michalska brilliantly evokes daily life under Russian occupation. Now more than ever, this memoir reads like a warning against history repeating, while at the same time offering a testament to human strength and to hope
- US-based translator currently lives in Philadelphia and has been a Translator-in-Residence at Princeton University, a National Endowment for the Arts Translation Fellow, and Literature and Humanities Curator at the Polish Cultural Institute New York
- Sean Gasper Bye's translations of Polish literature have been awarded the EBRD Literature Prize and the Asymptote Close Approximations Prize

Summary

A memoir of the Russian occupation of Ukraine in the 1930s and the mass deportation of Poles from the region.

The end of the 1920s, the author's first memory: a knock on the door and the arrest of her uncle, guilty of "anti-Soviet activities." He is to be executed. Born in 1923, a dozen or so kilometers from the pre-war Polish-Soviet border, Franceska Michalska is a citizen of occupied Ukraine. Her family, finding a nest of eggs to eat, miraculously survive the great famine of 1931–32 before falling victim to growing Stalinist terror and the mass deportation of Poles from the region to Kazakhstan. All the while, Franceska dreams of studying medicine. 8,000 km and infinite difficulties later, she enters Poland and becomes a doctor, finally obtaining the Polish nationality she never had. Writing in a heartfelt yet matter-of-fact style, Michalska brilliantly evokes daily life under Russian occupation. Now more than ever, this memoir reads like a warning against history repeating, while at the same time offering a testament to human strength and to hope.

Contributor Bio

FRANCESKA MICHALSKA was born in 1923 in Kamieniec Podolski, Ukraine. Miraculously, she survived the great famine of the era, and in 1936, when she was twelve, her family, along with thousands of Poles from pre-partition Poland, were exiled to Kazakhstan. During WWII she was sent to one of the Red Army field hospitals before being transferred to work in an orphanage. In 1941, she began medical studies in Almaty. Inching further and further west to other medical universities, first in Kharkiv, then in Chernivtsi, she finally found herself in Poland. In 1949 she graduated from medicine at the University of Wrocław. Until her death in 2016 Michalska remained a well-known pediatrician and was visited by patients from all over the country. On April 10, 2017, she became the patron of the Care and Treatment Institute for Children and Youth in Baciki Środa. *Stubborn Life* was a finalist for the COGITO Literary Award 2008, and has been published in Polish and French.

SEAN GASPER BYE's translations of Polish literature have been awarded the EBRD Literature Prize and the Asymptote Close Approximations Prize. He has been a Translator-in-Residence at Princeton University, a National Endowment for the Arts

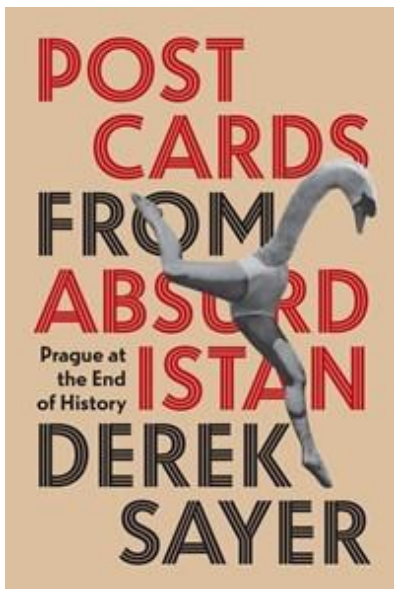

Princeton University Press
9780691264554
0691264554
Pub Date: 10/29/2024
On Sale Date: 10/29/2024
\$35.00/\$44.00 Can./£30.00
UK/€35.00 EU
Discount Code: SP
Trade Paperback

752 Pages
79 b/w illus.
History / Europe
HIS010010
9.3 in H | 6.1 in W
Status: **ACTIVE**

Postcards from Absurdistan

Prague at the End of History

Derek Sayer

Summary

A sweeping history of a twentieth-century Prague torn between fascism, communism, and democracy—with lessons for a world again threatened by dictatorship

Postcards from Absurdistan is a cultural history of Prague from 1938, when the Nazis destroyed Czechoslovakia's artistically vibrant liberal democracy, to 1989, when the country's socialist regime collapsed after more than four decades of communist party rule. Derek Sayer shows that Prague's twentieth century, far from being a story of inexorable progress toward some "end of history," whether fascist, communist, or democratic, was a tragicomedy of recurring nightmares played out in a land Czech dissidents dubbed Absurdistan. Situated in the eye of the storms that shaped the modern world, Prague holds up an unsettling mirror to the absurdities and dangers of our own times.

In a brilliant narrative, Sayer weaves a vivid montage of the lives of individual Praguers—poets and politicians, architects and athletes, journalists and filmmakers, artists, musicians, and comedians—caught up in the crosscurrents of the turbulent half century following the Nazi invasion. This is the territory of the ideologist, the collaborator, the informer, the apparatchik, the dissident, the outsider, the torturer, and the refugee—not to mention the innocent bystander who is always looking the other way and Václav Havel's greengrocer whose knowing complicity allows the show to go on. Over and over, Prague exposes modernity's dreamworlds of progress as confections of kitsch.

In a time when democracy is once again under global assault, *Postcards from Absurdistan* is an unforgettable portrait of a city that illuminates the predicaments of the modern world.

Contributor Bio

Derek Sayer is professor emeritus and a former Canada Research Chair at the University of Alberta. His other books include the award-winning *Prague, Capital of the Twentieth Century: A Surrealist History* and *The Coasts of Bohemia: A Czech History* (both Princeton).

Quotes

"Winner of the Canadian Jewish Literary Award for Scholarship"

"Finalist for the PROSE Award in European History, Association of American Publishers"

"Necessary." -Library Journal starred review

"Fascinating and capacious, *Postcards from Absurdistan* surveys Prague's anguished recent past, raising concerns for its future amid new global conflicts and challenges."
-Foreword Reviews

"Intriguing. . . . Covering literature, the graphic arts, music, philosophy, architecture, and photography, Sayer profiles a staggering cast of artists and intellectuals."
-Publishers Weekly

"Informative and illuminating."---**Alena Dvořáková, *Dublin Review of Books***

"[A] kaleidoscopic romp across five decades of intellectual, artistic, cultural, and political foment and creativity in Prague, from the Nazi Anschluss to the collapse of communism. . . . The book offers a magnificent and expansive collection of close

— ADVANCED BOOK INFORMATION —

— November 2024 | HB | 336pp | £25 | 9781911723745 | 216 x138mm | Politics / Europe —

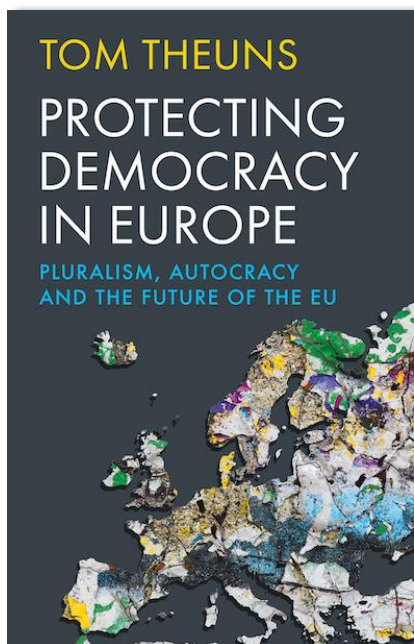

Protecting Democracy in Europe

Pluralism, Autocracy and the Future of the EU

Tom Theuns

- Why has the European Union failed to combat rising authoritarianism within its own ranks? And how can it defend democratic governance inside member countries?
- Theuns explores how the EU can protect democracy—eg. urgently correcting policies that make it complicit in democratic backsliding and much more.
- Considers the expulsion of the autocratic members of the European Union to ensure democratic governance within its member states.

The future of Europe as a community of democratic states is deeply uncertain. The European Union, founded to promote ‘ever closer’ integration, aims nominally for peaceful, prosperous cooperation. But this ideal has been battered by a series of bruising crises, and now by war.

Protecting Democracy in Europe examines how, in this brave new world, the EU can and must safeguard democratic governance within its member states. Reviewing the Union’s past responses, Tom Theuns demonstrates that its existing laws and policies are normatively and expressively incoherent. Its failure to defend democratic values is unsurprising: the EU’s existing toolbox is based on an impoverished conception of democracy, and runs counter to its fundamental principles. Close attention to speeches by European Commissioners shows that they see democracy in a technical and legalistic way. This perspective—‘democracy without politics’—is easy for would-be autocrats to exploit.

To protect democracy in Europe, Theuns argues, the EU must urgently correct policies that make it complicit in democratic backsliding. It must contain autocratic influences (within the strict limits of its political authority). And it must cultivate pluralist democracy within its constituent countries. But where this fails, he concludes, autocratic members should be expelled.

Tom Theuns is Senior Assistant Professor of Political Theory and European Politics at Leiden University's Institute of Political Science, and Associate Researcher at Sciences Po in Paris. He has published widely, including in *American Political Science Review*, the *Journal of Common Market Studies* and the *Journal of European Integration*.

— ADVANCED BOOK INFORMATION —

— November 2024 | Hardback | 352pp | £25 | 9781911723561 | 216x138mm | Current Affairs / Business / Russia —

New Perspectives on Eastern Europe and Eurasia Series

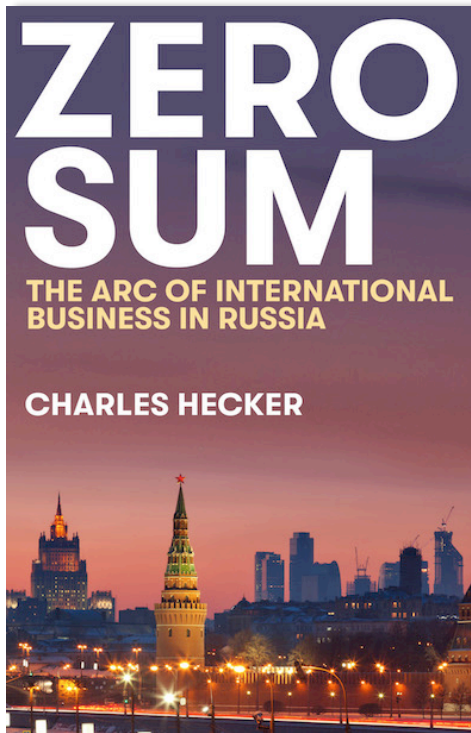

Zero Sum

The Arc of International Business in Russia

Charles Hecker

- An insider's account of the rise and fall of Western business ventures in post-Soviet Russia.
- A fluent Russian speaker, Charles Hecker draws on his experience of travelling and working in the Soviet Union and Russia in the past 40 years.
- What can businesses and economists learn from the process of change in such unstable international markets?

When the hammer and sickle flag came down at the Kremlin at the end of 1991, a feverish new market opened for business: Russia. In 2022, as soon as Putin's troops invaded Ukraine, that market started to collapse, as Western firms fled the skyscrapers of Moscow and other centres of business.

No other country of this scale has transformed itself so dramatically, so quickly—not just once, but twice. Over three turbulent decades, a wild, proto-capitalist free-for-all came seductively close to becoming a predictable place to do business. And then it all unravelled. Russia's post-Soviet years have seen phenomenal successes, crushing failures, and the creation and destruction of enormous fortunes. How did it all happen?

Charles Hecker tells the gripping, three-act story of international business in Russia since the fall of the USSR. What have global companies learnt—or failed to learn—about Russia over the course of this adventure? And beyond Russia, what do we now understand about the way countries and companies interact in the face of relentless change? *Zero Sum* brings to life the complexity, the nuance and the vivid colour of one of the greatest experiments in the history of global commerce.



Charles Hecker has spent forty years travelling and working in the Soviet Union and Russia. He has worked as a journalist and a geopolitical risk consultant, and has lived in Miami, Moscow and London. A fluent Russian speaker, he holds degrees from the University of Pennsylvania and Harvard University.

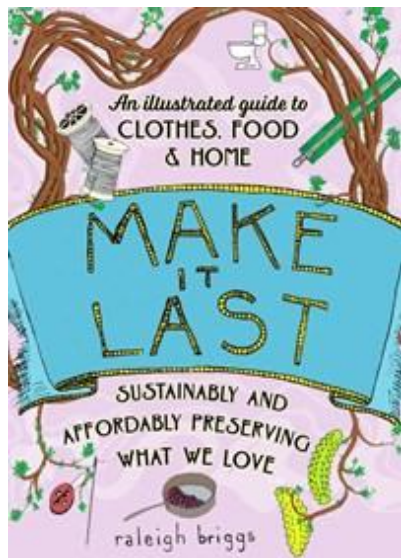

Make It Last (2nd Edition)

Sustainably and Affordably Preserving What We Love

Raleigh Briggs

Summary

Make It Last: Sustainably and Affordably Preserving What We Love is an illustrated guide to clothes and food and home.

Raleigh Briggs bridges the gap between life in a disposable culture and the basic skills needed to save money and live more sustainably. This book teaches you how to extend the lives of the things you love by repairing clothing, preserving home-grown food, and even repairing your kitchen sink.

Briggs takes her longtime commitment to community building through the DIY movement and shares her valuable experience with the reader through a conversational tone in her hand drawn and illustrated guide.

The Utne Reader described Raleigh's work as "A forceful antidote to the cheapening of thrift culture: a meticulously hand-lettered, pint-size volume. When you raise your fist against the values that derailed our economy, lift this book in it." Now you can save money and save the planet while saving your prized possessions!

Contributor Bio

Raleigh Briggs is an herbalist, potion maker, DIY homemaker, and the best-selling author of Make Your Place: Affordable, Sustainable Nesting Skills, and of several DIY zines. She lives with her husband and two needy cats in Seattle, WA.

Illustrations



Microcosm Publishing
9781648414046
1648414044
Pub Date: 10/22/2024
\$12.99/\$16.99 Can.
Trade Paperback

128 Pages
Carton Qty: 76
House & Home / Sustainable Living
HOM022000
Series: Good Life

6.8 in H | 5.3 in W | 0.5 in T
Status: **FORTHCOMING**



Milkweed Editions
9781639550968
1639550968
Pub Date: 10/15/2024
On Sale Date: 10/15/2024
Ship Date: 8/30/2024
\$18.00/\$23.99 Can./£12.99
UK/€15.99 EU
Discount Code: TP
Trade Paperback

208 Pages
Carton Qty: 52
Nature / Essays
NAT024000
8.5 in H | 5.5 in W
Status: **FORTHCOMING**

Related Products

Also Available

The Angel in the Marketplace
9780226486321 \$32.00
Oneida 9781250043085 \$27.00

Ebooks

9781639550975

The Science of Last Things

Essays on Deep Time and the Boundaries of the Self

Ellen Wayland-Smith

Key Selling Points

- For readers who enjoyed Margaret Renkl's *Late Migrations*, Lydia Millet's *We Loved it All*, and Rebecca Solnit's celebrated essays—works that are both intimate and encompassing as it probes human existence and our place in the world.
- Powered by beautiful prose and deeply moving moments of grace, Wayland-Smith is an immensely talented writer who immerses the reader on every page and at every level.
- Glowing endorsements from Ada Limón, David L. Ulin, and Briallen Hopper
- The book's engagement with end of life care, health—mental and physical, life cycles—human and animal, cancer, science, organic matter, deep time, and ancient philosophy provide opportunities for rich coverage and appeal to a wide readership.

Summary

"Offering a deeply necessary, clear-eyed look at who we are as flesh-and-bone bodies during the climate crisis, this is a book that searches and finds meaning in both the hard truths and the value of wonder."—Ada Limón

In this luminous collection of essays, Ellen Wayland-Smith probes the raw edges of human existence, those periods of life in which our bodies remind us of our transience and the boundaries of the self dissolve.

From the Old Testament to Maggie Nelson, these explorations are grounded in a rich network of associations. In an essay on the postpartum body, Wayland-Smith interweaves her experience as a mother with accounts of phantom limbs and Greek mythology to meditate on moments when pieces of our being exist outside our bodies. In order to comprehend diagnoses of depression and breast cancer, she delves into LA hippie culture's love affair with crystals and Emily Dickinson's geological poetry. Her experience with chemotherapy leads to reflection on Western medicine and its intolerance of death and the healing capacity of nature. And throughout, she challenges the false separation between the human and the "primeval, animal mode of being."

At once intimate and expansive, *The Science of Last Things* peels back layers of human thought and behavior, breaking down our modern conceptions of individuality and reframing us as participants in a world of astounding elegance and mystery.

Contributor Bio

Ellen Wayland-Smith is the author of *Oneida* and *The Angel in the Marketplace*. Her work has appeared in *Guernica*, *Catapult*, *The Millions*, *Longreads*, *The American Scholar*, and the *Los Angeles Review of Books*. She teaches at the University of Southern California and lives in Los Angeles.

Quotes

Praise for *The Science of Last Things*

"Smart, harrowing, and lyrically powerful, *The Science of Last Things* celebrates interconnectedness as a way to not just understand how we are made, but how we might come to terms with our own end. Offering a deeply necessary, clear-eyed look at who we are as flesh-and-bone bodies during the climate crisis, this is a book that searches and finds meaning in both the hard truths and the value of wonder." —**Ada Limón, 24th Poet Laureate of the United States**

"In *The Science of Last Things*, Ellen Wayland-Smith seamlessly blends the life of the body and the life of the mind, writing less about endings per se (although those, as

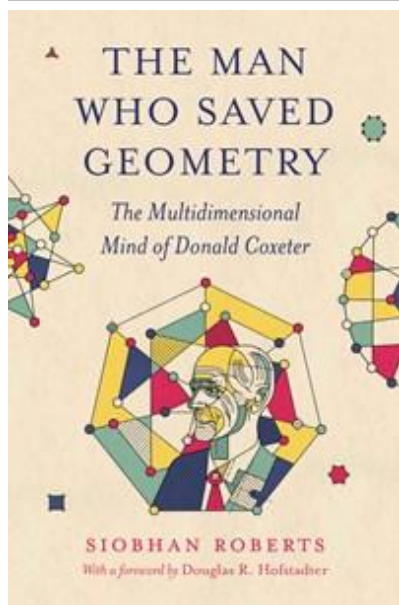

The Man Who Saved Geometry

The Multidimensional Mind of Donald Coxeter

Siobhan Roberts

Summary

An illuminating biography of one of the greatest geometers of the twentieth century

Driven by a profound love of shapes and symmetries, Donald Coxeter (1907–2003) preserved the tradition of classical geometry when it was under attack by influential mathematicians who promoted a more algebraic and austere approach. His essential contributions include the famed Coxeter groups and Coxeter diagrams, tools developed through his deep understanding of mathematical symmetry. *The Man Who Saved Geometry* tells the story of Coxeter's life and work, placing him alongside history's greatest geometers, from Pythagoras and Plato to Archimedes and Euclid—and it reveals how Coxeter's boundless creativity reflects the adventurous, ever-evolving nature of geometry itself. With an incisive, touching foreword by Douglas R. Hofstadter, *The Man Who Saved Geometry* is an unforgettable portrait of a visionary mathematician.

Contributor Bio

Siobhan Roberts is an award-winning science journalist and regular contributor to the *New York Times*. She is the author of *Genius at Play* and *Wind Wizard* (both Princeton).

Unpublished Endorsements

"Imagine you grew up as a super fan of a musician or artist who made your world make sense, but in this case it's the mathematician who inspired the titanic artists of the era. You crawled through libraries to trace every last little scrap of their work, the deep tracks. You grew up in a weird hippie geometric house inspired by their insights. You spent hours internalizing shapes that were hard to imagine, that they were the first to describe. And then this book, which brings the person into focus. Imagine your heart beating just a little faster as you open this book. That is what will happen."
—Jaron Lanier, computer scientist, author, composer, pioneer of virtual reality

"As someone much of whose academic research has been on algebraic structures discovered by, and named after, Donald Coxeter, I found this book an absolute joy. Siobhan Roberts has a rare gift for biography. Her narrative is full of compelling anecdotes and her writing on complex topics is beautifully clear. This is a fabulous book!"
—Sarah Hart, author of *Once upon a Prime*

"There is perhaps no better way to prepare for the scientific breakthroughs of tomorrow than to learn the language of geometry."
—Brian Greene, author of *The Elegant Universe*

"There is no substitute for Coxeter, and no substitute for this long-overdue treatment of his life."
—Jordan Ellenberg, *Washington Post*

"Siobhan Roberts has achieved something extraordinary with this book, a paean to a geometer and all geometry. It tells a brave, compelling story. It comprehends a whole universe—our universe—of kaleidoscopes and crystals, groups and symmetry, bicycles and snowflakes, music and movement. It is lucid, beautiful, and exalting."
—James Gleick, author of *Chaos*

"[*The Man Who Saved Geometry*] offers poignant looks into Coxeter's soul."
—Jeffrey Rosenthal, *Globe and Mail*

"An elegant biography of an elegant man."
—John Horton Conway, Princeton University

Princeton University Press
 9780691264745
 0691264740
 Pub Date: 10/29/2024
 On Sale Date: 10/29/2024
 \$29.95/\$38.00 Can./£25.00
 UK/€29.99 EU
 Discount Code: SP
 Trade Paperback

416 Pages
 74 b/w illus.
 Mathematics / History &
 Philosophy
 MAT015000
 8 in H | 5.3 in W
 Status: **ACTIVE**

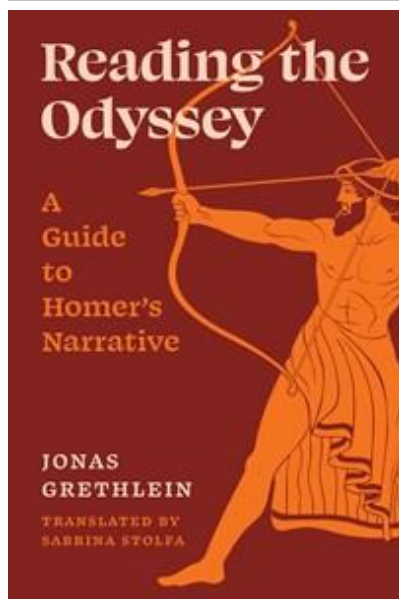

Princeton University Press
9780691182490
0691182493
Pub Date: 11/12/2024
On Sale Date: 11/12/2024
\$35.00/\$44.00 Can./£30.00
UK/€35.00 EU
Discount Code: S
Hardcover

328 Pages
20 b/w illus. 1 map.
Literary Criticism / Ancient &
Classical
LIT004190

9.3 in H | 6.1 in W
Status: **FORTHCOMING**

Reading the Odyssey

A Guide to Homer's Narrative

Jonas Grethlein, Sabrina Stolfa

Summary

A fresh and original introduction to the *Odyssey*—and how it continues to shape literature, film, art and even the ways we make sense of our lives

Reading the Odyssey is an introduction to Homer's masterpiece like no other. It combines a cultural and intellectual history of the epic with an in-depth exploration of its unique and influential narrative structure and the ways it continues to inform issues of identity, meaning and experience.

Reading the Odyssey begins with a broad history of the epic's reception and interpretation, its place in cultural and intellectual history and its influence today on literature, film and art. After introducing the literary form of the *Odyssey*, the book turns to its main focus: the layered narrative that lies at the heart of the poem. Taking readers on a tour of the epic, Jonas Grethlein shows the nuanced ways the *Odyssey* uses a wide variety of narrative forms and functions. At the same time, he highlights how we all rely on narratives, first used by Homer, to form identities, forge communities and make sense of our lives.

The result is a compelling guide to the *Odyssey* that demonstrates why it continues to speak so powerfully to so many readers today.

Contributor Bio

Jonas Grethlein is Chair in Greek literature at the University of Heidelberg. His books include *Ancient Greek Texts and Modern Narrative Theory*, *The Ancient Aesthetics of Deception*, *Aesthetic Experiences and Classical Antiquity*, and *The Greeks and Their Past*.

Unpublished Endorsements

"Divine Calypso, the sweetly singing Sirens, the one-eyed, man-eating giant Polyphemus—what's not to like about Homer's *Odyssey*? Distinguished Homerist Jonas Grethlein helps us share the eponymous hero's era- and genre-defining journey, full of spills as well as thrills, and one that we wish would never end."—**Paul Cartledge, author of *Thebes: The Forgotten City of Ancient Greece***

"*Reading the Odyssey* is not merely a brilliant, up-to-date, engaging and accessible new introduction to Homer's alluring text by one of the leading experts in the field; it also doubles as a guide to the rich afterlife of the story of Odysseus's homecoming in art, literature and critical theory. Grethlein takes our reading of the *Odyssey* into the twenty-first century and makes even difficult aspects of the text and its reception a pleasure to think about."—**Julia Kindt, author of *The Trojan Horse and Other Stories***

"This rich account of Homer's *Odyssey* deftly ranges across a vast terrain. Like its subject, it takes its reader on multiple luminous adventures—through scholarship, reception history and theoretical analyses."—**Fiona Macintosh, University of Oxford**

Comp Titles

Reading Homer's Odyssey	Myrsiades, Kostas	Bucknell University Press	4/5/2019	9781684481316 1684481317	\$62.95 USD	Hardcover	Literary Criticism
Homeric Effects in Vergil's Narrative	Barchiesi, Alessandro	Princeton University Press	1/4/2015	9780691161815 069116181X	\$44.00 USD	Hardcover	Literary Criticism
Reading the Odyssey	Grethlein, Jonas	Princeton University Press	11/12/2024	9780691182490 0691182493	\$35.00 USD	Hardcover	Literary Criticism

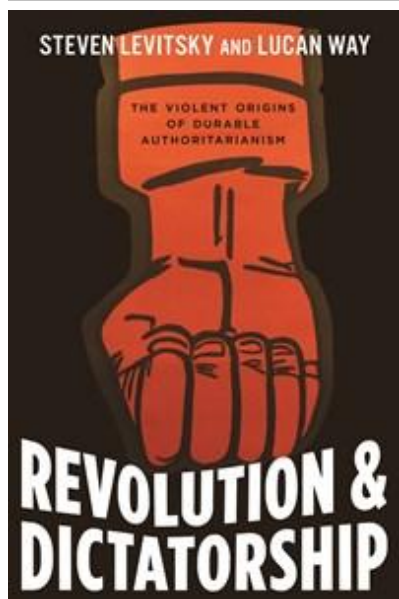

Princeton University Press
 9780691223582
 0691223580
 Pub Date: 10/29/2024
 On Sale Date: 10/29/2024
 \$27.95/\$35.00 Can./£22.00
 UK/€27.99 EU
 Discount Code: SP
 Trade Paperback

656 Pages
 10 b/w illus. 14 tables.
 Political Science / Political
 Ideologies
 POL042030

8 in H | 5.3 in W
 Status: **ACTIVE**

Revolution and Dictatorship

The Violent Origins of Durable Authoritarianism

Steven Levitsky, Lucan Way

Summary

Why the world's most resilient dictatorships are products of violent revolution

Revolution and Dictatorship explores why dictatorships born of social revolution—such as those in China, Cuba, Iran, the Soviet Union, and Vietnam—are extraordinarily durable, even in the face of economic crisis, large-scale policy failure, mass discontent, and intense external pressure. Few other modern autocracies have survived in the face of such extreme challenges. Drawing on comparative historical analysis, Steven Levitsky and Lucan Way argue that radical efforts to transform the social and geopolitical order trigger intense counterrevolutionary conflict, which initially threatens regime survival, but ultimately fosters the unity and state-building that supports authoritarianism.

Although most revolutionary governments begin weak, they challenge powerful domestic and foreign actors, often bringing about civil or external wars. These counterrevolutionary wars pose a threat that can destroy new regimes, as in the cases of Afghanistan and Cambodia. Among regimes that survive, however, prolonged conflicts give rise to a cohesive ruling elite and a powerful and loyal coercive apparatus. This leads to the downfall of rival organizations and alternative centers of power, such as armies, churches, monarchies, and landowners, and helps to inoculate revolutionary regimes against elite defection, military coups, and mass protest—three principal sources of authoritarian breakdown.

Looking at a range of revolutionary and nonrevolutionary regimes from across the globe, *Revolution and Dictatorship* shows why governments that emerge from violent conflict endure.

Contributor Bio

Steven Levitsky is the David Rockefeller Professor of Latin American Studies, professor of government, and director of the David Rockefeller Center for Latin American Studies at Harvard University. His books include *How Democracies Die* and *Transforming Labor-Based Parties in Latin America*. **Lucan Way** is Distinguished Professor of Democracy in the Department of Political Science and codirector of the Petro Jacyk Program for the Study of Ukraine at the University of Toronto. He is the author of *Pluralism by Default*. Levitsky and Way are the coauthors of *Competitive Authoritarianism*.

Quotes

"Shortlisted for the Lionel Gelber Prize, Lionel Gelber Foundation"

"Winner of the Juan Linz Best Book Prize, Democracy & Autocracy section of the American Political Science Association"

"A Choice Outstanding Academic Title of the Year"

"

A sweeping historical analysis.

"---**Dexter Roberts, *Washington Post***

"A clear and comprehensive analysis."---**Cady Lang and Angela Haupt, *Time***

"Two of the most prolific and respected scholars of democracy and dictatorship, Steven Levitsky and Lucan Way . . . bring together their immense regional and theoretical expertise in their new book, *Revolution and Dictatorship*. For those trying to

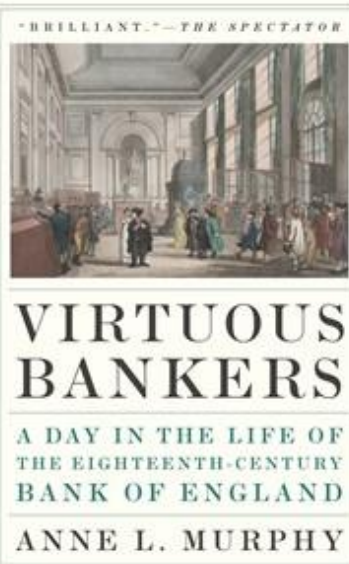

Virtuous Bankers

A Day in the Life of the Eighteenth-Century Bank of England

Anne L. Murphy

Summary

An intimate account of the eighteenth-century Bank of England that shows how a private institution became "a great engine of state"

The eighteenth-century Bank of England was an institution that operated for the benefit of its shareholders—and yet came to be considered, as Adam Smith described it, "a great engine of state." In *Virtuous Bankers*, Anne Murphy explores how this private organization became the guardian of the public credit upon which Britain's economic and geopolitical power was based. Drawing on the voluminous and detailed minute books of a Committee of Inspection that examined the Bank's workings in 1783–84, Murphy frames her account as "a day in the life" of the Bank of England, looking at a day's worth of banking activities that ranged from the issuing of bank notes to the management of public funds.

Murphy discusses the bank as a domestic environment, a working environment, and a space to be protected against theft, fire, and revolt. She offers new insights into the skills of the Bank's clerks and the ways in which their work was organized, and she positions the Bank as part of the physical and cultural landscape of the City: an aggressive property developer, a vulnerable institution seeking to secure its buildings, and an enterprise necessarily accessible to the public. She considers the aesthetics of its headquarters—one of London's finest buildings—and the messages of creditworthiness embedded in that architecture and in the very visible actions of the Bank's clerks. Murphy's uniquely intimate account shows how the eighteenth-century Bank was able to deliver a set of services that were essential to the state and commanded the confidence of the public.

Contributor Bio

Anne L. Murphy is professor of history and deputy vice-chancellor (education) at the University of Portsmouth. Before joining academia, she worked for twelve years in the City of London trading interest rate and foreign exchange derivatives. She is the author of *The Origins of English Financial Markets*.

Quotes

"A Financial Times Book to Read in 2023"

"This is a model of economic history, acute, profound and diverting."---**Ferdinand Mount, *London Review of Books***

"[*Virtuous Bankers*] is compelling and lively, and will please both academic and general readers. . . . Murphy's thorough research sets a high standard for future work in this field."---**Perry Gauci, *Literary Review***

"Brilliant."---**Jesse Norman, *The Spectator***

"Fascinating. . . . [Murphy] makes the technicalities of financial history accessible and personal."---**Martin Daunton, *BBC History Magazine***

"Murphy turns what could have been a dry bureaucratic history into a fascinating and engaging read. Above all, her book highlights the value of approaching the big questions in economic history with a sensitivity to the routines and rhythms of everyday life."---**James Taylor, *History Today***

"The modus operandi of the Bank of England is described assiduously in [this] delightful new book." -Grant's Interest Rate Observer

"[Murphy] excels in putting this microhistory in the larger context of the bank's



Princeton University Press
9780691248523
0691248524
Pub Date: 10/22/2024
On Sale Date: 10/22/2024
\$22.95/\$28.99 Can./£14.99
UK/€22.99 EU
Discount Code: SP
Trade Paperback

288 Pages
12 b/w illus. 4 tables.
Business & Economics / Economic
History
BUS023000
8 in H | 5.3 in W
Status: **ACTIVE**

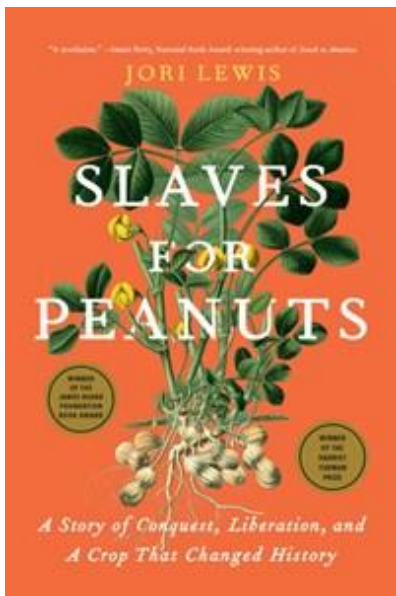

Slaves for Peanuts

A Story of Conquest, Liberation, and a Crop That Changed History

Jori Lewis

Key Selling Points

Major prizewinner: Nabbed the 2023 James A. Beard Foundation Book Prize—the top prize for a book in the food category—and the 2023 Harriet Tubman Prize from the Schomburg Center at the New York Public Library.

National Media: Critically acclaimed by NPR and key literary, food, and environmental publications including *CivilEats*, *Guernica*, and *Nature*.

A-List blurbs for hardcover: Glowing praise from Tiya Miles, Imani Perry, and Adam Hochschild.

Up and coming talent: Lewis won a prestigious Whiting Award to complete the manuscript; buzz is developing around her as a writing of critical acclaim on the order Imani Perry and Tiya Miles—a serious writer with popular appeal on issues of race, history, and justice.

Summary

Winner, James Beard Foundation Book Award for Reference, History, and Scholarship

Winner, Harriet Tubman Prize

“*Slaves for Peanuts* plumbs a fascinating and disturbing slice of history, shining a light on another glaring example of Western hypocrisy and oppression.” —NPR Books

“A complex story crossing time and oceans” (National Public Radio), Jori Lewis’s prizewinning *Slaves for Peanuts* deftly weaves together the natural and human history of a crop that transformed the lives of millions. “With elegant prose and engaging details” (National Book Award–winner Imani Perry), Lewis reveals how demand for peanut oil in Europe ensured that slavery in Africa would persist well into the twentieth century, long after the European powers had officially banned it in the territories they controlled.

“This informative and compassionate account unearths a little-known chapter in the history of slavery and European imperialism” (*Publishers Weekly*), recreating a world on the coast of Africa that is breathtakingly real and unlike anything modern readers have experienced. *Slaves for Peanuts* is “told in rich detail through the eyes of West African men and women” (*Civil Eats*)—from an African-born French missionary harboring runaway slaves, to the leader of a Wolof state navigating the politics of French imperialism—who challenge our most basic assumptions of the motives and people who supported human bondage.

At a time when Americans are grappling with the enduring consequences of slavery, here is a new and revealing chapter in its global history.

Contributor Bio

Jori Lewis is an award-winning journalist who writes about agriculture and the environment. Her reports have appeared on PRI’s *The World* and in *Discover Magazine*, *Pacific Standard*, and the *Virginia Quarterly Review*. She is also a contributing editor of *Adi*, a literary magazine about global politics. In 2018, she received the prestigious Whiting Grant for Creative Nonfiction. Lewis splits her time between Illinois and

The New Press
9781620979174
1620979179
Pub Date: 10/8/2024
On Sale Date: 10/8/2024
\$18.99/\$24.99 Can./£13.99
UK/€16.99 EU
Discount Code: TP
Trade Paperback

384 Pages
Carton Qty: 24
Print Run: 5K
History / Africa
HIS001050
8.5 in H | 5.5 in W | 0.9 in T
Status: **FORTHCOMING**

Related Products

Also Available

Slaves for Peanuts
9781620971567 \$29.99
9781620971574

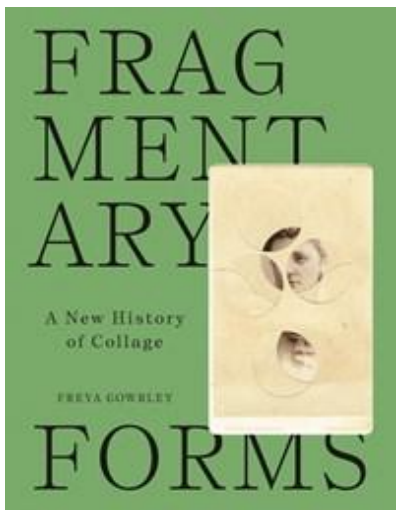

Fragmentary Forms

A New History of Collage

Freya Gowrley

Summary

A beautifully illustrated global history of collage from the origins of paper to today

While the emergence of collage is frequently placed in the twentieth century when it was a favored medium of modern artists, its earliest beginnings are tied to the invention of paper in China around 200 BCE. Subsequent forms occurred in twelfth-century Japan with illuminated manuscripts that combined calligraphic poetry with torn colored papers. In early modern Europe, collage was used to document and organize herbaria, plant specimens, and other systems of knowledge. In the eighteenth and nineteenth centuries, collage became firmly associated with the expression of intimate relations and familial affections. *Fragmentary Forms* offers a new, global perspective on one of the world's oldest and most enduring means of cultural expression, tracing the rich history of collage from its ancient origins to its uses today as a powerful tool for storytelling and explorations of identity.

Presenting an expansive approach to collage and the history of art, Freya Gowrley explores what happens when overlapping fragmentary forms are in conversation with one another. She looks at everything from volumes of pilgrims' religious relics and Victorian seaweed albums to modernist papiers collés by Pablo Picasso and Georges Braque and quilts by Faith Ringgold exploring African-American identity. Gowrley examines the work of anonymous and unknown artists whose names have been lost to history, either by accident or through exclusion.

Featuring hundreds of beautiful images, *Fragmentary Forms* demonstrates how the use of found objects is an important characteristic of this unique art form and shows how collage is an inclusive medium that has given voice to marginalized communities and artists across centuries and cultures.

Contributor Bio

Freya Gowrley is a leading scholar of the cultural lives of images and objects. She is based at the University of Bristol, where she writes about the relationship between art and identity from the early modern period to the present day. She is the author of *Domestic Space in Britain, 1750–1840: Materiality, Sociability, and Emotion*.

Illustrations



Princeton University Press
 9780691253749
 0691253749
 Pub Date: 11/12/2024
 On Sale Date: 11/12/2024
 \$60.00/\$75.00 Can./£50.00
 UK/€60.00 EU
 Discount Code: TC
 Hardcover

400 Pages
 300 illus.
 Art / History
 ART015000

10.5 in H | 8.3 in W
 Status: **FORTHCOMING**

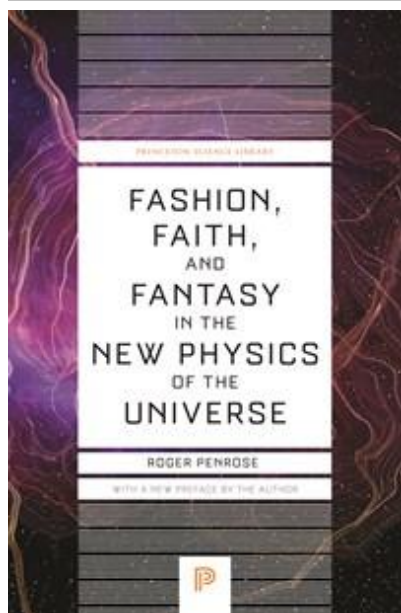

Princeton University Press
9780691264301
0691264309
Pub Date: 10/22/2024
On Sale Date: 10/22/2024
\$21.95/\$27.99 Can./£15.99
UK/€21.99 EU
Discount Code: TP
Trade Paperback

536 Pages
186 b/w illus.
Science / Philosophy & Social
Aspects
SCI075000
Series: Princeton Science Library
8.5 in H | 5.5 in W
Status: **ACTIVE**

Fashion, Faith, and Fantasy in the New Physics of the Universe

Roger Penrose

Summary

Nobel Prize–winning physicist Roger Penrose questions some of the most fashionable ideas in physics today, including string theory

What can fashionable ideas, blind faith, or pure fantasy possibly have to do with the scientific quest to understand the universe? Surely, theoretical physicists are immune to mere trends, dogmatic beliefs, or flights of fancy? In fact, acclaimed physicist and bestselling author Roger Penrose argues that researchers working at the extreme frontiers of physics are just as susceptible to these forces as anyone else. In this provocative book, he argues that fashion, faith, and fantasy, while sometimes productive and even essential in physics, may be leading today's researchers astray in three of the field's most important areas—string theory, quantum mechanics, and cosmology.

Arguing that string theory has veered away from physical reality by positing six extra hidden dimensions, Penrose cautions that the fashionable nature of a theory can cloud our judgment of its plausibility. In the case of quantum mechanics, its stunning success in explaining the atomic universe has led to an uncritical faith that it must also apply to reasonably massive objects, and Penrose responds by suggesting possible changes in quantum theory. Turning to cosmology, he argues that most of the current fantastical ideas about the origins of the universe cannot be true, but that an even wilder reality may lie behind them. Finally, Penrose describes how fashion, faith, and fantasy have ironically also shaped his own work, from twistor theory, a possible alternative to string theory that is beginning to acquire a fashionable status, to "conformal cyclic cosmology," an idea so fantastic that it could be called "conformal crazy cosmology."

The result is an important critique of some of the most significant developments in physics today from one of its most eminent figures.

Contributor Bio

Roger Penrose, one of the world's foremost theoretical physicists, has won numerous prizes, including the Nobel Prize and the Albert Einstein Medal, for his fundamental contributions to general relativity and cosmology. He is the bestselling author, with Stephen Hawking, of *The Nature of Space and Time* (Princeton). Penrose's other books include *Cycles of Time: An Extraordinary New View of the Universe* and *The Road to Reality: A Complete Guide to the Laws of the Universe* (both Vintage). He is the Rouse Ball Professor of Mathematics Emeritus at the University of Oxford and lives in Oxford, England.

Quotes

"Physics has been at an awkward impasse for the past century. Two theories--quantum mechanics and general relativity--are widely believed to be true. . . . But they contradict each other in basic ways--they cannot both be entirely true. In *Fashion, Faith, and Fantasy in the New Physics of the Universe* . . . Roger Penrose, an elder statesman of physics, considers the problem. As intellectually offbeat as he is eminent . . . He ventures here some novel ways in which the two theories might be reconciled."
-Wall Street Journal

"Penrose gets to the heart of modern physics' problem with subjectivity in this insightful and provocative pop-sci title. . . . [A] rewarding discussion of scientific stumbles in the search for truth." -Publishers Weekly

"It is always inspiring to read Penrose's uncompromisingly independent perspective on physics."---**Richard Dawid, *Nature***

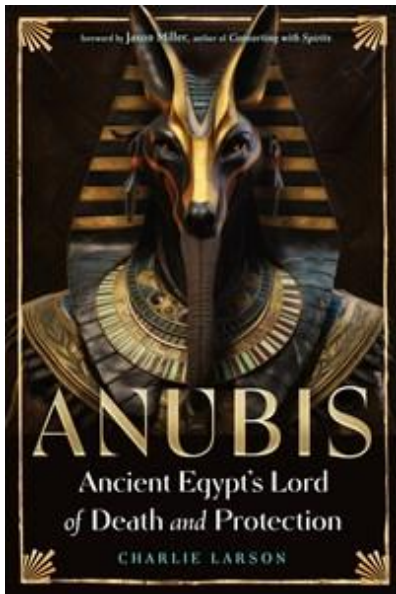

Weiser Books
9781578638413
1578638410
Pub Date: 4/11/2024
On Sale Date: 4/11/2024
\$18.95
Trade Paperback

224 Pages
12 black and white photos
Carton Qty: 32
Body, Mind & Spirit / Occultism
OCC016000
22.9 cm H | 15.2 cm W | 285.8 g
Wt
Status: **ACTIVE**

Related Products

Display

Ancient Egyptian Magic for
Modern Witches 9781578637379
\$18.95

Anubis—Ancient Egypt's Lord of Death and Protection

Charlie Larson, Jason Miller

Key Selling Points

- Anubis (illustrated as a dog- or jackal-headed god) is among the most ancient and beloved Egyptian gods.
- For spiritual and magical practitioners enchanted by the practices of ancient Egypt.
- Egypt's original Lord of the Dead, Anubis continued to be the most active participant in the after-death process, supervising rituals that determine what befalls the dead soul.

Summary

"A poignant, powerful, inclusive, and deeply personal journey to meet the Great God Anubis. Filled with solid historical information, as well as practical contemporary rituals, magick, healing practices, and prayers, this book drew me in, opened my heart, and made me love dear Anubis even more."

—Michael Butler Smith, author of *Embracing Isis*

Anubis is Egypt's original Lord of the Dead. That title was eventually transferred to Osiris, but even then, Anubis continued to be the most active participant in the after-death process, supervising rituals that determined what would befall the dead soul. He is credited as the inventor of mummification. A shrine to Anubis, one of the most significant gods of ancient Egypt, was discovered within Tutankhamun's tomb. The image of Anubis has evolved into a veritable symbol of ancient Egypt.

Usually identified as a jackal or as a jackal-headed man, Anubis's domain extends beyond death—he is a guardian of children and travelers and a finder of lost things. Anubis's adopted mother, the goddess Isis, became popular outside Egypt, with temples in Rome and as far as the British Isles. As her guardian, Anubis traveled with her. He is as modern as he is ancient, appearing in comic books, video games, and in the book *American Gods* and its television adaptation. In modern times, Anubis has emerged as a sacred patron of mediums and occultists.

In this practical guide to working with Anubis, author Charlie Larson focuses the spotlight squarely on the jackal-headed god. Steeped in history and mythology, *Anubis—Ancient Egypt's Lord of Death and Protection* features devotional practices and modern worship that includes rituals, prayers, invocations, correspondences, altars, and epithets. The book leads the reader on a journey of exploration into all things Anubis, delving into his various facets—death deity, psychopomp, and protector.

Contributor Bio

Charlie Larson has been a practicing witch and eclectic Pagan for over two decades. Charlie is passionate about nature, ancestral magick, energy healing, and shadow work. He is a priest of Anubis and works closely with Hekate and other deities. A leader in his coven since the 2000s, he has written and taught in various online communities since 2016. He currently resides in California. You can connect with him at anubislightandshadow.com.

Quotes

"Charlie Larson's elegant prose results in an approachable text that deftly guides those who seek to form a personal relationship with Anubis. A gifted teacher, Larson condenses what he's learned from his decades of research concerning the practices of ancient Anubites and suggests modern ways to connect with this mysterious Lord of Death. *Anubis: Ancient Egypt's Lord of Death and Protection* is a unique and useful addition to any discerning reader's bookshelf."

—Martha Kirby Capo, author of *Thrifty Witchery*

"This book is a deep, delicious swim in the darkness of the Egyptian underworld as

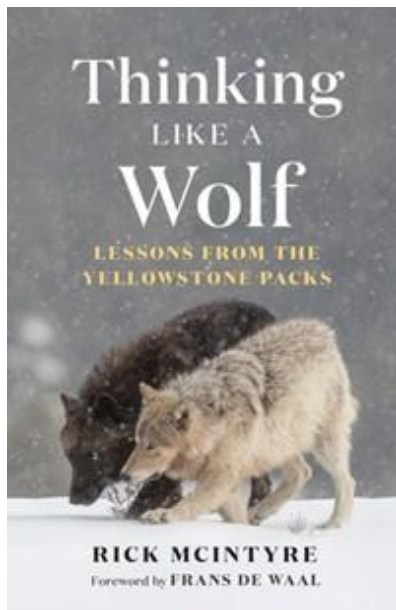

Greystone Books
9781778401251
1778401252
Pub Date: 10/29/2024
On Sale Date: 10/29/2024
Ship Date: 9/27/2024
\$27.95/£18.99 UK
Discount Code: HC
Hardcover with dust jacket

272 Pages
Color photographs, 3 maps
Carton Qty: 40
Nature / Animals
NAT044000
Series: The Alpha Wolves of
Yellowstone

8.5 in H | 5.5 in W
Status: **ACTIVE**

Related Products

Also Available

The Alpha Female Wolf
9781778401770 \$18.95
The Redemption of Wolf 302
9781778400759 \$18.95
The Unlikely Hero
9781778400223 \$18.95
The Alpha Female Wolf
9781771648585 \$27.95
The Reign of Wolf 21
9781771649964 \$18.95
The Redemption of Wolf 302
9781771645270 \$27.95
The Reign of Wolf 21
9781771645249 \$26.95
The Rise of Wolf 8
9781771647809 \$18.95
The Rise of Wolf 8
9781771645218 \$26.95

Ebooks

9781778401268

Thinking Like a Wolf

Lessons From the Yellowstone Packs

Rick McIntyre, Frans de Waal

Key Selling Points

- **THE FIFTH INSTALLMENT IN AN AWARD-WINNING, BELOVED SERIES:** including *The Rise of Wolf 8*, *The Reign of Wolf 21* (Winner of the Reading the West Award—Narrative Nonfiction), *The Redemption of Wolf 302*, and *The Alpha Female Wolf*.
- **AS SEEN ON "THIS AMERICAN LIFE":** Ranked #3 in overall podcast episodes on Apple, Rick McIntyre discussed the Alpha Wolves of Yellowstone series on "This American Life."
- **MOVIE TIE-IN:** The first three books in the series have been optioned for film and will feature the prominent stories of Yellowstone wolves as well as the relationships within the pack.
- **THE MOST FAMOUS WOLF WATCHER IN THE WORLD:** McIntyre has recorded more wild wolf sightings than any other person on the planet and is a highly sought after speaker.
- **ENGAGING STORYTELLER:** McIntyre's blend of biography and storytelling conveys wolf stories in a way we can relate to and understand.
- **MAPS AND FULL COLOR PHOTO INSERT**

Summary

Book Five in the Award-Winning "Alpha Wolves of Yellowstone" series

"Rick's writing is so vivid, so powerful, that I feel I have been right there with him among the wolves of Yellowstone."—Jane Goodall

Following eight major wolf personalities, *Thinking Like a Wolf* draws on decades of field notes to uncover the challenges and triumphs of Yellowstone's wolf packs, from the "chief historian of the most famous wolf population in the world" (*Washington Post*).

In his latest book, award-winning author and renowned wolf researcher, Rick McIntyre, explores the intricate world of wolf behavior in Yellowstone National Park and highlights the individual character traits that allow wolf packs to thrive.

Unveiling power struggles, pack politics, the roles of family protection, inter-pack conflicts, and more, Rick skillfully follows the intricacy of packs and the unique attributes each wolf has. In these true stories, he celebrates the many lessons we can learn from wolf packs and the dynamic personalities that enable them to expand across new territories amidst adversity.

Weaving an impressive web of politics and power, family cooperation and commitment, rivalry and resilience, *Thinking Like a Wolf* provides readers with a unique window into the fascinating inner workings of wolf packs.

Contributor Bio

Rick McIntyre is a wolf behaviorist who has spent more than forty years watching wild wolves in America's national parks, twenty-eight of those years in Yellowstone, where he has accumulated over 100,000 wolf sightings and educated the public about the park's wolves. He is retired from the National Park Service and is currently a faculty affiliate at the University of Montana.

Frans de Waal was a primatologist and ethologist. He was the Charles Howard

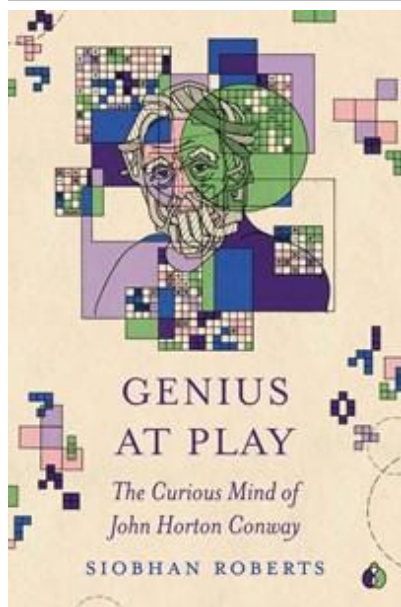

Genius at Play

The Curious Mind of John Horton Conway

Siobhan Roberts

Summary

A multifaceted biography of a brilliant mathematician and iconoclast

A mathematician unlike any other, John Horton Conway (1937–2020) possessed a rock star’s charisma, a polymath’s promiscuous curiosity, and a sly sense of humor. Conway found fame as a barefoot professor at Cambridge, where he discovered the Conway groups in mathematical symmetry and the aptly named surreal numbers. He also invented the cult classic Game of Life, a cellular automaton that demonstrates how simplicity generates complexity—and provides an analogy for mathematics and the entire universe. Moving to Princeton in 1987, Conway used ropes, dice, pennies, coat hangers, and the occasional Slinky to illustrate his winning imagination and share his nerdish delights. *Genius at Play* tells the story of this ambassador-at-large for the beauties and joys of mathematics, lays bare Conway’s personal and professional idiosyncrasies, and offers an intimate look into the mind of one of the twentieth century’s most endearing and original intellectuals.

Contributor Bio

Siobhan Roberts is an award-winning science journalist and regular contributor to the *New York Times*. She is the author of *The Man Who Saved Geometry* and *Wind Wizard* (both Princeton).

Unpublished Endorsements

“An engaging, broad-ranging, and sometimes hilarious portrait of one of the most charismatic and curious minds in the history of mathematics.”—**Brian Eno**

“*Genius at Play* is a portrait of one creative genius by another. Absolutely brilliant.”—**Sylvia Nasar, author of *A Beautiful Mind***

“Roberts has written a very unusual book about a very unusual subject. Her chronicling of Conway’s life is interwoven with her narration of the adventure she undertook in trying to capture his story. The result is a wonderful biography that brings this bewildering, fascinating, and utterly charming mathematical genius back to life.”
—**Ingrid Daubechies, Duke University**

“[A] virtuoso juggling of narrative speeds, reminiscences, implausible digressions and long passages of precise, comprehensible mathematics.”—**Michael Harris, *Nature***

“Makes you laugh with surprise.”—**Jordan Ellenberg, *Wall Street Journal***

“A delightful metabiography—playful indeed—of a brilliant iconoclast.”—**James Gleick, author of *The Information* and *Time Travel***

Princeton University Press
9780691266404
0691266409
Pub Date: 10/29/2024
On Sale Date: 10/29/2024
\$29.95/\$38.00 Can./£25.00
UK/€29.99 EU
Discount Code: SP
Trade Paperback

480 Pages
62 b/w illus.
Biography & Autobiography
BIO000000
8 in H | 5.3 in W
Status:**ACTIVE**

Comp Titles

King of Infinite Space	Roberts, Siobhan	Walker Books	9/19/2006	9780802714992 0802714994	\$27.95 USD	Hardcover with dust jacket	Biography & Autobiography
The Man from the Future	Bhattacharya, Ananyo	W. W. Norton & Company	2/22/2022	9781324003991 1324003995	\$30.00 USD	Hardcover	Biography & Autobiography
Genius At Play	Roberts, Siobhan	Bloomsbury USA	10/11/2016	9781620405956 1620405954	\$20.00 USD	Trade Paperback	Biography & Autobiography

Leibniz in
His World

THE MAKING
OF A SAVANT

AUDREY
BOROWSKI

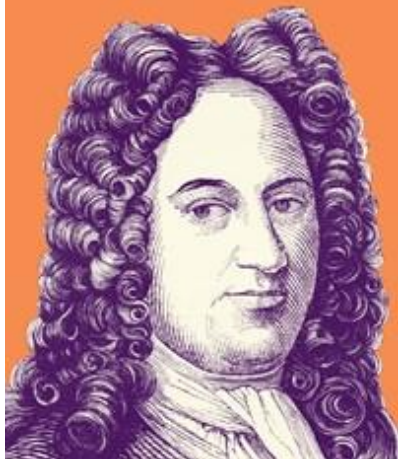

Princeton University Press
9780691260747
0691260745
Pub Date: 11/12/2024
On Sale Date: 11/12/2024
\$35.00/\$44.00 Can./£30.00
UK/€35.00 EU
Discount Code: S
Hardcover

320 Pages
Biography & Autobiography
/ Philosophers
BIO009000

9.3 in H | 6.1 in W
Status: **ACTIVE**

Leibniz in His World

The Making of a Savant

Audrey Borowski

Summary

A sweeping intellectual biography that restores the Enlightenment polymath to the intellectual, scientific, and courtly worlds that shaped his early life and thought

Described by Voltaire as “perhaps a man of the most universal learning in Europe,” Gottfried Wilhelm Leibniz (1646–1716) is often portrayed as a rationalist and philosopher who was wholly detached from the worldly concerns of his fellow men. *Leibniz in His World* provides a groundbreaking reassessment of Leibniz, telling the story of his trials and tribulations as an aspiring scientist and courtier navigating the learned and courtly circles of early modern Europe and the Republic of Letters.

Drawing on extensive correspondence by Leibniz and many leading figures of the age, Audrey Borowski paints a nuanced portrait of Leibniz in the 1670s, during his “Paris sojourn” as a young diplomat and in Germany at the court of Duke Johann Friedrich of Hanover. She challenges the image of Leibniz as an isolated genius, revealing instead a man of multiple identities whose thought was shaped by a deep engagement with the social and intellectual milieus of his time. Borowski shows us Leibniz as he was known to his contemporaries, enabling us to rediscover him as an enigmatic young man who was complex and all too human.

An exhilarating work of scholarship, *Leibniz in His World* demonstrates how this uncommon intellect, torn between his ideals and the necessity to work for absolutist states, struggled to make a name for himself during his formative years.

Contributor Bio

Audrey Borowski is a research fellow with the Desirable Digitalisation project, a joint initiative of the universities of Bonn and Cambridge that investigates how to design AI and other digital technologies in responsible ways. She received her PhD from the University of Oxford and is a regular contributor to the *Times Literary Supplement* and *Aeon*.

Unpublished Endorsements

“The figure Audrey Borowski examines in this fascinating and original book is not the venerated elderly Leibniz in the old-fashioned wig but the brash and somewhat naive young man who pressed his ambitious and audacious projects on possible patrons as he struggled to establish himself in the wider world. In telling his story, Borowski shows us what it was like to be a young person aspiring to citizenship in the Republic of Letters.”—**Daniel Garber, Princeton University**

“A startlingly fine piece of original, lucid, and brilliant scholarly work. Showing Leibniz in Paris at a key moment for him as he navigates the world of state-funded science, Borowski paints a meticulous and nuanced portrait of a surprisingly hesitant Leibniz, who is unwilling to play the professional game of scholarship. This is the best political and intellectual biography we have of Leibniz.”—**Jacob Soll, author of *The Free Market: The History of an Idea***

“Borowski challenges the notion that Leibniz’s faith and nationality were the main reasons he was so little known and respected at the time of his residence in Paris and his early years in Hanover, and he was not elected to the Académie. Her argument, together with her consistently gripping and lucid accounts of Leibniz’s work, make this a book that has something important to say to a wide academic readership.”—**Tom Jones, author of *George Berkeley: A Philosophical Life***